

QUICK-ACTING JAW CHANGE SYSTEM

The RÖHM key bar chucks with quick-acting jaw change system convince in two ways. On the one hand the jaws can be quickly and easily turned, changed or offset over the entire clamping range within a few seconds. On the other the key bar chucks convince with maximum clamping forces and maximum accuracy thanks to direct force transfer via the key bar system. Large, straight surfaces transmitting the force from the key bar to the jaw teeth guarantee long life and produce a very high clamping force combined with an accuracy which is twice high as required by DIN 6386. The high clamping force is achieved without much physical effort by manually turning the key.



Video DURO-T

KEY BAR CHUCK WITH QUICK-ACTION JAW CHANGE SYSTEM

The RÖHM key bar chucks with quick-acting jaw change system are used successfully in areas where extremely high clamping forces, high concentricity and reliable long-term repeatability are required. Thanks to the quick-acting jaw change system, the jaws can be quickly and easily turned, changed or offset over the entire clamping range within a few seconds.

ADVANTAGES AT A GLANCE

- ⊕ Maximum clamping forces thanks to direct force transfer via the key bar system
- ⊕ Maximum concentricity and axial run-out tolerance
- ⊕ High user-friendliness thanks to quick-acting jaw change system

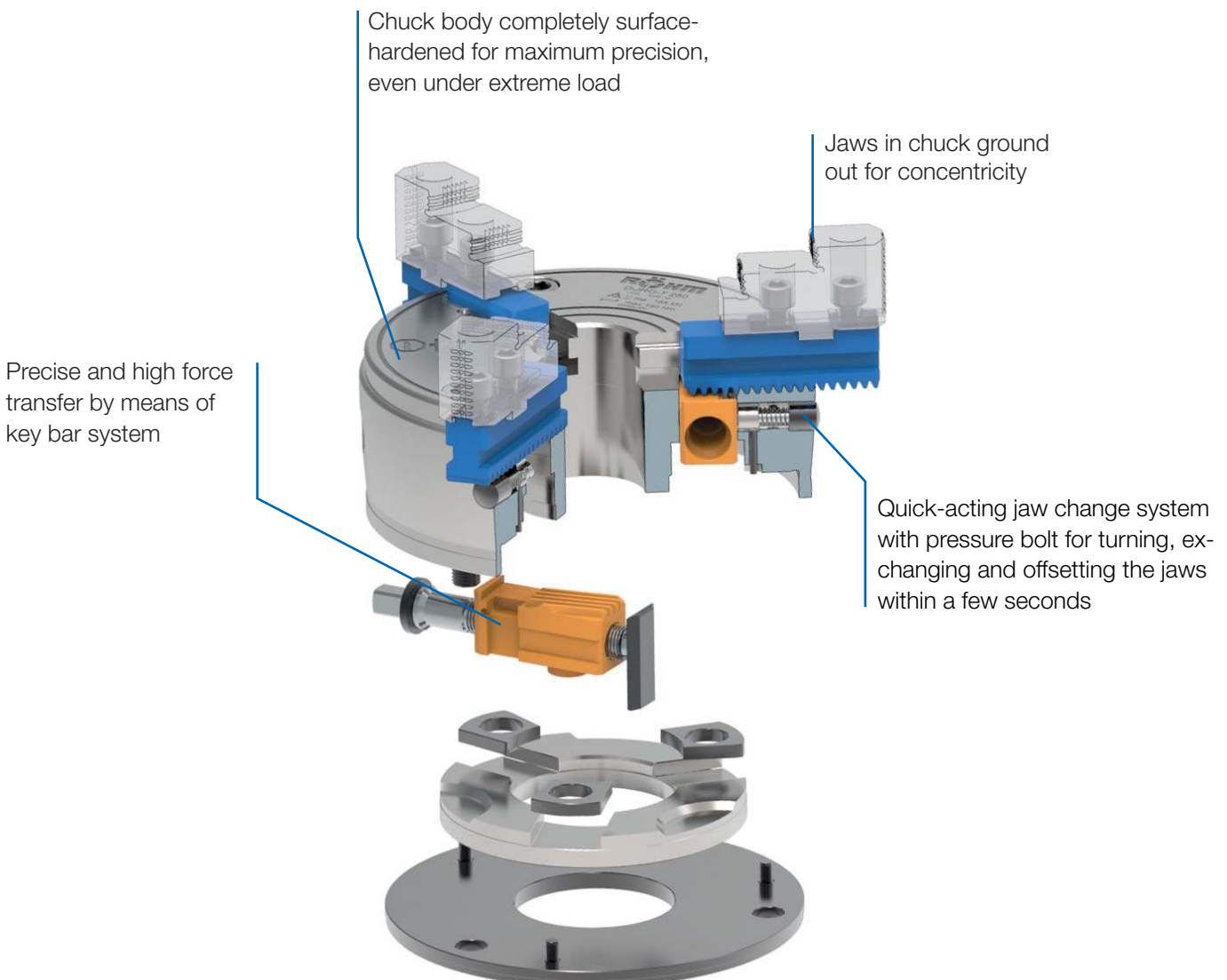

DURO-T

The DURO-T key bar chuck guarantees maximum precision, maximum clamping force and is completely balanced ex works

Principle of operation

Thanks to the tangentially arranged threaded spindle (1), the force is transferred via a key bar (2) having an internal thread. The key bar moves the drive ring via a slide (3). Two other slides in the drive ring (4) transfer the forces to the other two key bars. The key bars having an inclined profile engage in the base jaws (5), thereby guaranteeing exact, centric clamping. The jaws can be quickly and easily turned, changed or offset over the entire clamping range within a few seconds. To do this, the key bars must be disengaged by turning the key to the left; the indicator pin (6) will project here. In this position, the jaws are secured against being hurled out in the event the machine spindle is started up unintentionally. Therefore, the gate valve (7) of each jaw must be unlocked via the corresponding pressure bolt (8) on the outer diameter of the chuck.

Large, straight-line force transfer surfaces between the key bar and jaw toothing yield a very high clamping force over a long service life and precision which is twice as high as prescribed by DIN 6386. The high clamping force is achieved without exerting any special amount of force by manually turning the key.

Lubrication

To maintain the clamping force, rotary chucks must be lubricated regularly. You will find corresponding information in the operating instructions which are enclosed with every chuck. For easy maintenance, DURO-T chucks are equipped with three additional grease nipples on the front side.

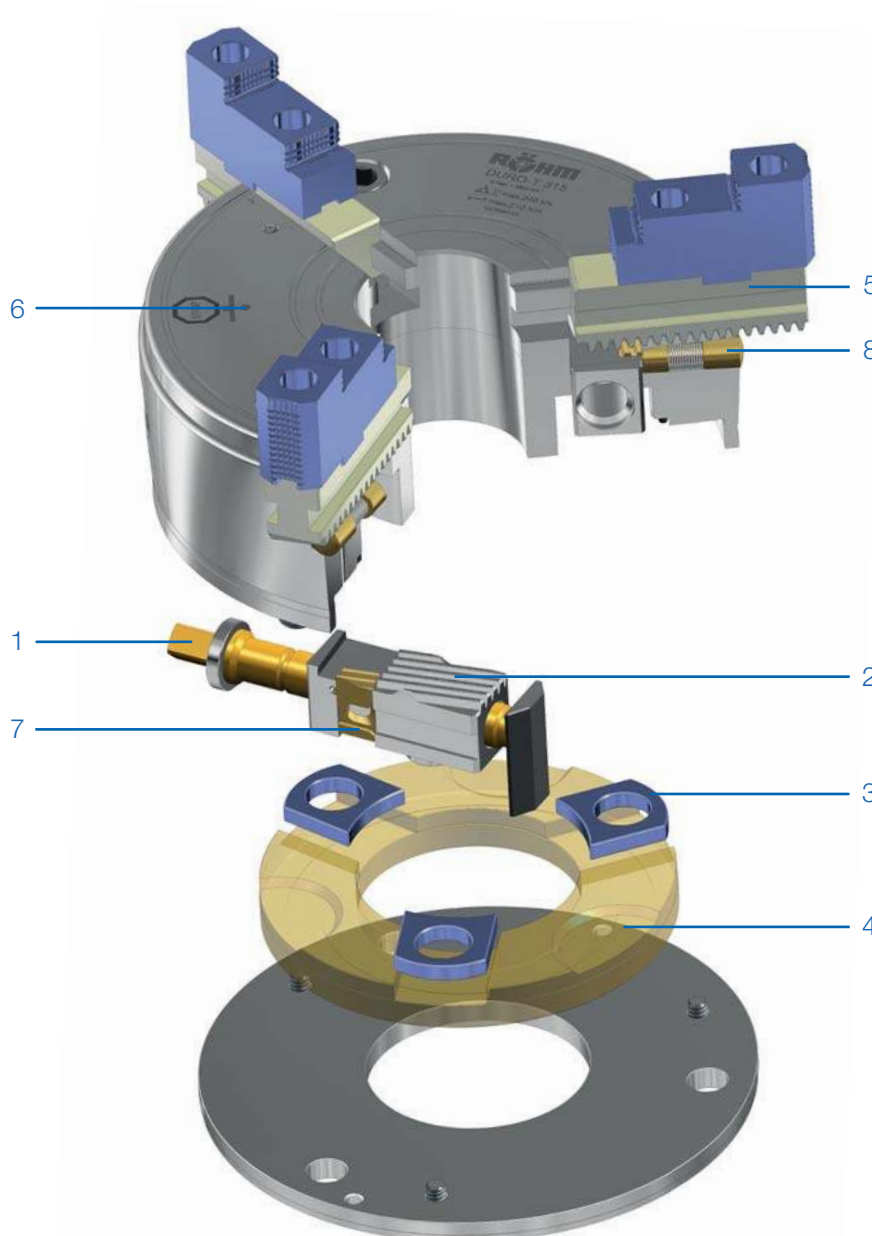

DURO-T



APPLICATION

Optimized for turning applications, which require extremely high clamping forces, maximum concentricity, as well as reliable long-term repeatability. In combination with a base plate, stationary use on milling machines, dividing units and machining centers.

TYPE

Key bar chuck with quick-action jaw change system. Guaranteed maximum jaw precision as far as these are only used on the same chuck, and base and top jaws are kept screwed on for recurring work.

CUSTOMER BENEFITS

- ⊕ Maximum clamping force thanks to key bar system
- ⊕ Concentricity and axial run-out tolerance twice as exact as required in DIN precision class 1
- ⊕ Very high jaw-change repeatability
- ⊕ Balanced and jaws in chuck ground out for concentricity

TECHNICAL FEATURES

- With jaw safeguard
- Chuck body completely surface-hardened
- Visual marking for quick jaw adjustment
- External shape incl. splash-water edge
- Fastening options for strongly stressed sliding surfaces
- Incl. safety key
- High corrosion protection

A08
Cylindrical centre mount

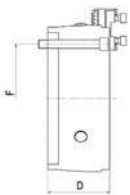

Size	Inch	Through-hole mm	With one-piece reversible jaws	With base jaws and reversible top jaws	D mm	Speed max. min ⁻¹	Max. Torque Nm	Max. total clamping force kN
125	5	32	437475	-	46,5	6000	40	23
160	6 1/4	42	437476	437490	63	5400	120	73
200	8	52	437477	437491	81	4600	155	114
250	10	62	437478	437492	92	4200	190	185
315	12 1/2	87	437479	437493	111	3300	210	240
400	15 3/4	102	437480	437494	118	2200	260	260
500	20	162	437481	437495	118	1900	320	290
630	25	252	-	437496	143	1100	350	320

1) at size 630 chuck body without convex outer contours
Further sizes and mountings available on request

A08
ISO 702-3 (DIN 55027), with studs and locknuts

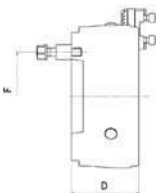

Size	Mount short taper	Through-hole mm	With one-piece reversible jaws	With base jaws and reversible top jaws	D mm	F mm	Speed max. min ⁻¹	Max. Torque Nm	Max. total clamping force kN
125	5	32	437499	-	67	104,8	6000	40	23
160	5	42	437501	437548	78	104,8	5400	120	73
160	6	42	437502	437549	85	133,4	5400	120	73
200	5	52	437504	437551	96	104,8	4600	155	114
200	6	52	437505	437552	97	133,4	4600	155	114
250	6	62	437509	437556	108	133,4	4200	190	185
250	8	62	437510	437557	110	171,4	4200	190	185
315	8	87	437512	437559	129	171,4	3300	210	240
315	11	87	437513	437560	131	235	3300	210	240
400	8	102	437515 ▲	437562 ▲	138	171,4	2200	260	260
400	11	102	437516 ▲	437563 ▲	138	235	2200	260	260
500	11	162	437519 ▲	437566 ▲	156	235	1900	320	290
500	15	162	437520 ▲	437567 ▲	163	330,2	1900	320	290
630	11	192	-	437568 ▲	165	235	1100	350	320
630	15	252	-	437569 ▲	167	330,2	1100	350	320

1) at size 630 chuck body without convex outer contours
Further sizes and mountings available on request

Jaws DURO-T

A28

One-piece jaw EB, set, diagonally toothing, hardened

Item no.	Chuck Size	Contents of delivery	Jaw length	Jaw height	Jaw width
212121	125	set	50	34	14
094000	160	set	77,7	45	20
094001	200	set	94,7	60	22
094002	250	set	114	70	26
094003	315	set	130	79	32
094043	400/500	set	167	93	45

Additionally or later purchased, hardened jaws must be ground out in the chuck.
For jaws which are applied later, send in the chuck.

A28

Unstepped Jaw BL, set, diagonally toothing, unstepped, soft, material 16MnCr5

Item no.	Chuck Size	Contents of delivery	Jaw length	Jaw height	Jaw width
304864	125	set	53	34	14
241699	160	set	84,4	45	20
249678	200	set	98,4	60	22
249679	250	set	118,7	70	26
249680	315	set	136,6	79	32
249681	400/500	set	173,6	93	45

A28

Reversible top jaw UB, set, hardened

Item no.	Chuck Size	Contents of delivery	Jaw length	Jaw height	Jaw width
094012	160	set	61,5	32,5	20,4
094013	200	set	70,5	38	24,4
094014	250	set	92	50	34,4
094015	315	set	107	56	35,7
094045	400/500	set	130	72	50,4
140715	630	Satz	185	102	68

Additionally or later purchased, hardened jaws must be ground out in the chuck.
For jaws which are applied later, send in the chuck.

A28

Unstepped top jaw AB, set, standard design, soft, material 16MnCr5

Item no.	Chuck Size	Contents of delivery	Jaw length	Jaw height	Jaw width
212123	125	set	55	25,5	20,7
094008	160	set	85	36,5	20,3
094009	200	set	105	40	22
094010	250	set	125	50	30,4
094011	315	set	145	50	34,3
094046	400/500	set	180	73	50,5
140716	630	set	260	102	68

A28

Unstepped top jaw AB, set, extendend design, soft, material 16MnCr5

Item no.	Chuck Size	Contents of delivery	Jaw length	Jaw height	Jaw width
137055	160	set	85	42,5	24,4
137056	200	set	105	51	34,3
137057	250	set	125	75	50,5
137058	315	set	145	74	50,5

 Configure your individual clamping jaws online! www.web2product.biz

Jaws DURO-T

A28

Base jaw GB, set, diagonally toothed, with mounting bolts



Item no.	Chuck Size	Contents of delivery	Jaw length	Jaw width
212119	125	set	47	14
094004	160	set	74	20
094005	200	set	90	22
094006	250	set	110	26
094007	315	set	125	32
094044	400/500	set	160	45
140194	630	set	230	65

C 21

Reversible claw-type top jaws, standard design, tongue and groove, large clamping range, 1 piece hardened



Item no.	Chuck Size	Jaw length	Jaw height	Jaw width
137060	160	66	37,5	24
137119	400/500	124	62	50
151289	630	144	78	70

C 21

Reversible claw-type top jaws, standard design, tongue and groove, small clamping range, 1 piece, hardened



Item no.	Chuck Size	Jaw length	Jaw height	Jaw width
137061	160	66	37,5	20
137064	200	81	43	24
137108	250	90	55	34
137114	315	100	62	34
137120	400/500	124	62	50

C 21

Reversible claw-type top jaws, standard design, tongue and groove, middle sized clamping range, 1 piece, hardened



Item no.	Chuck Size	Jaw length	Jaw height	Jaw width
137062	160	56	37,5	20
137065	200	66	43	24
137109	250	72	55	34
137115	315	86	62	34
137121	400/500	100	62	50

C 21

Reversible claw-type top jaws, large design, tongue and groove, small clamping range, 1 piece hardened



Item no.	Chuck Size	Jaw length	Jaw height	Jaw width
137066	160/200	79	43	34
137110	250	80	55	50
137116	315	93	62	50

Configure your individual clamping jaws online! www.web2product.biz

Jaws DURO-T

C 21

Reversible claw-type top jaws, large design, tongue and groove, large clamping range, 1 piece, hardened



Item no.	Chuck Size	Jaw length	Jaw height	Jaw width
137067	160/200	81	43	34
137111	250	90	55	50
137117	315	106	62	50

C 21

Reversible claw-type top jaws, large design, tongue and groove, middle sized clamping range, 1 piece, hardened



Item no.	Chuck Size	Jaw length	Jaw height	Jaw width
137068	160/200	66	43	34
137112	250	72	55	50
137118	315	86	62	50

C 21

Draw-down jaws, without clamping inserts, diagonally toothing, 1 piece, without clamping inserts



Item no.	Chuck Size	Jaw length	Jaw height	Jaw width
141037	160	84,4	43,5	20
141039	200	98,4	47,5	22
141041	250	118,7	58,5	26
141043	315	136,4	63,9	32
141045	400/500	173,6	73,4	45

C 21

Draw-down jaws, additional clamping range, for interchangeable clamping inserts, diagonally toothing, 1 piece, without clamping inserts



Item no.	Chuck Size	Jaw length	Jaw height	Jaw width
141038	160	84,4	43,5	20
141040	200	98,4	47,5	22
141042	250	118,7	58,5	26
141044	315	136,4	63,9	32
141046	400	173,6	73,4	45
141048	500	173,6	73,4	45

Jaws DURO-T

C 15

Interchangeable clamping inserts, 1 piece with claws



Item no.	Chuck Size
141049	160/200
141052	250/315
141055	400/500/630

C 15

Interchangeable clamping inserts, 1 piece with serrated toothing



Item no.	Chuck Size
141050	160/200
141053	250/315
141056	400/500

C 15

Interchangeable clamping inserts, 1 piece with heat treatable surface



Item no.	Chuck Size
141051	160/200
141054	250/315
141057	400/500

C15

Jaw mounting bolt, piece



Item no.	Size	Thread	Contents of delivery
243893	125	M6x10	piece
200182	160/200	M8x1x22	piece
200183	250	M12x1,5x30	piece
202402	315	M12x1,5x35	piece
227618	400/500	M16x1,5x40	piece
249388	630	M20x50	piece

Accessories DURO-T

Accessories DURO-T

A08

Base plate with fixing slots

Complete with mounting screws and fixed T-slot nuts. Other sizes available on request.



Item no.	Size
143163	160
143165	200
143167	250

A08

Key



Item no.	Size	Square	L mm
212124	125	8	85
094016	160	10	140
094017	200	12	160
094018	250	14	220
094019	315	17	230
094047	500	19	250
332938	630	24	410

Only for stationary used chucks

A08

Safety key



Item no.	Size	Square	L mm
242172	125	8	85
242173	160	10	140
242174	200	12	160
242175	250	14	220
242176	315	17	230
242177	500	19	250
332939	630	24	410

corresponding with DIN 1550 for rotating chucks

A08

Chip guard, set



Item no.	Size	Contents of delivery
212122	125	set
236439	160	set
236440	200	set
236441	250	set
236442	315	set
236443	500	set

C15

Special grease F80 for lathe chucks

For lubrication and conservation of chucking power



Item no.	Design	Contents
308555	Cartridge	0,5 kg
028975	Tin	1 kg

Technical Data DURO-T

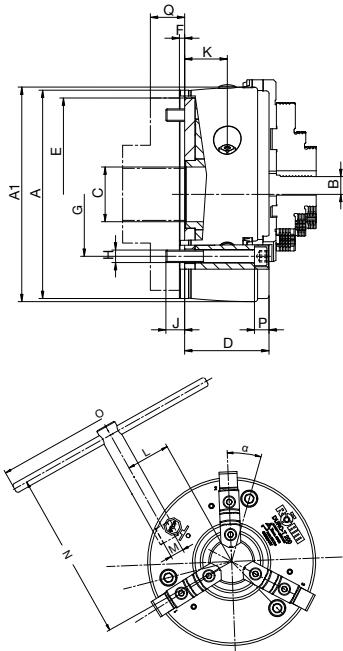

Chuck size A		125	160	200	250	315	400	500	630
Outer diameter	A1	128	164	206	256	322	407	507	630
Jaw movement	B	4,8	6,2	6,8	8	10,2	12,5	12,5	14
Bore	C	32	42	52	62	87	102	162	252
Bore can be enlarged	C max.	35	45	55	75	102	130	180	270
	D	46,5	63	81	92	111	118	118	143
	E ^{H6}	115	145	185	235	300	380	460	580
	F	4	5	5	6	6	6	6	6
	G	100	125	160	200	250	315	400	520
	H	3xM8	3xM10	3xM12	3xM16	3xM20	3xM24	3xM24	3xM24
	J	12	15	18	25	30	37	37	37
	K	22,5	31,5	43	47	59	57,7	57,5	72
	L	32,5	42	53,5	66,5	86	110	152,5	196
	M	SW8	SW10	SW12	SW14	SW17	SW19	SW19	SW24
	N	117	182	211	284	309	359	356	570
	O	180	210	270	450	500	600	600	600
	P	8,5	13	14	17	21	25	25	29
	Q	17	30	30	35	35	40	45	55
Min. thickness of flange									
Moment of inertia GD2 ¹⁾	kgm ²	0,01	0,03	0,10	0,29	0,87	2,37	5,78	17,04
	α	21° 35'	22°	18°	19°	17°	20°	42°	69° 30'
approx. kg	kg	4,0	9,3	18,6	34,5	64	112	166	300

1) The moment of inertia was measured with base jaws but without top jaws or back plate

The bore could be enlarged (measure C, at surcharge)

■ Enlarged bore max.

Max. permissible speed

The maximum permissible speed has been fixed so that 1/3 of the gripping force is still available as residual gripping force if the maximum gripping is applied and the chuck is fitted with its heaviest jaws. The jaws may not project beyond the outside diameter of the chuck. The chuck must be in perfect condition. The specification DIN 6386 Part 1 shall be observed.

Chuck size		125	160	200	250	315	400	500	630
Max. speed	min ⁻¹	6000	5400	4600	4200	3300	2200	1900	1100

Gripping force

The gripping force is the sum total of all jaw forces acting radially on the stationary workpiece.

The specified gripping forces are standard values.

They apply to chucks in a perfect condition which have been lubricated with RÖHM grease F79 and F80.

Chuck size		125	160	200	250	315	400	500	630
Torque applied on key 1)	Nm	10	40	60	70	80	90	100	100
Total gripping force 1)	kN	8,5	30	48	66	80	95	102	102
Torque applied on key	Nm	40	120	155	190	210	260	320	350
Max. total gripping force	kN	23	73	114	185	240	260	290	320

1) maintaining the accuracy

At this torque the clamping jaws have been ground at the factory, for testing the chuck must be clamped with this torque

Chuck capacities of jaw steps

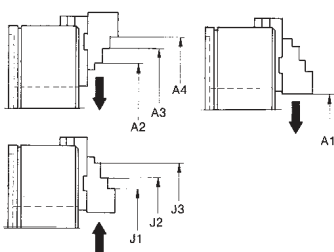

Chuck size		125	160	200	250	315	400	500	630
External chucking	A1	3-30	5-51	7-70	8-97	12-131	16-168	40-256	20-322
	A2	31-65	45-91	58-123	82-172	93-216	119-278	167-360	200-490
	A3	63-97	89-135	114-179	-	-	-	-	-
	A4	95-129	115-161	142-207	163-253	201-323	260-413	308-501	360-650
Internal chucking	J1	26-59	67-105	71-131	99-182	102-213	120-272	166-360	184-489
	J2	57-91	93-132	99-159	-	-	-	-	-
	J3	89-123	135-174	154-214	178-261	207-319	260-412	306-500	341-646

Jaw dimensions DURO-T

Reversible one-piece jaw **EB**, hardened and ground, jaw steps not ground

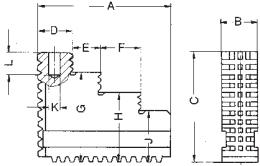

Block jaw **BL**, unstepped, soft, thread and jaw guides hardened and ground

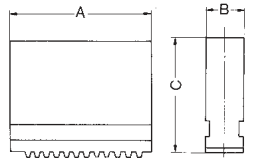

Reversible top jaw **UB**, completely hardened, cross tenon ground, jaw steps not ground

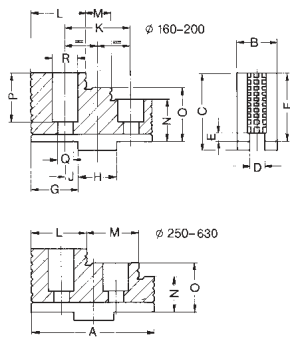

Chuck size	125	160	200	250	315	400+500
A	50	77,7	94,7	114	130	167
B	14	20	22	26	32	45
C	34	45	60	70	79	93
D	10,7	20,6	23	41,5	40,2	50,5
E	16	18,9	19,5	40,3	54	71
F	16	22	28	-	-	-
G	29	37,5	50	56	64	73
H	24	30	40	-	-	-
J	19	22,5	30	42	49	53
K	-	8	10	13	13	20
L	-	16	15	19,5	19,5	30
Jaw approx. kg	0,400	0,500	0,635	1,135	1,835	3,665

Chuck size	125	160	200	250	315	400+500
A	53	84,4	98,4	118,7	136,6	173,6
B	14	20	22	26	32	45
C	34	45	60	70	79	93
Jaw approx. kg	0,435	0,500	0,900	1,535	2,400	5

Chuck size	160	200	250	315	400+500	630
A	61,5	70,5	92	107	130	185
B	20,4	24,4	34,4	35,7	50,4	68
C	37	43	55	62	79	110
D	8	10	12	12	18	24
E	3	3,5	3,5	3,5	4,5	4,5
F	32,5	38	50	56	72	102
G	22,5	25,5	30	35,5	41,4	59
H	18	20	20	26	30	40
J	7	10	10	14	15	21
K	32	40	40	54	60	82
L	26,5	28,5	41	40	51	80
M	13	14	40,5	54	71	80
N	17,5	18	22	26	32	42
O	25	28	36	41	52	72
P	23,5	29	39	40	57	82
Q	9	9	14	14	18	22
R	15	15	20	20	26	33
T ¹⁾	38,5	45	57	63,6	80,6	114
Jaw approx. kg	0,200	0,335	0,800	1,135	2,535	6,350

1) Dimension marked on base jaw

Unstepped soft top jaw **AB**, for turning out special chucking diameters

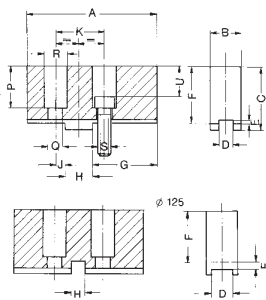

Dimensions for extendend design

Chuck size	125	160	200	250	315	400+500	630				
A	55	85	85	105	105	125	125	145	145	180	260
B	20,7	20,3	24,4	22	34,3	30,4	50,5	34,3	50,5	50,5	68
C	31,3	41	47	45	56	55	80	56	80	80	110
D	14	8	8	10	10	12	12	12	12	18	24
E	3,3	3	3	3,5	3,5	3,5	3,5	3,5	3,5	4,5	4,5
F	25,5	36,5	42,5	40	51	50	75	50	74	73	102
G	25	42	42	50	50	70	70	74	74	100	150
H	5	18	18	20	20	20	20	26	26	30	40
J	7,5	7	7	10	10	10	10	14	14	15	21
K	20	32	32	40	40	40	40	54	54	60	82
P	24	27,5	33,5	31	42	39	54	34	48	58	83
Q	6,5	9	9	9	9	14	14	14	14	18	22
R	11	15	15	15	15	20	20	20	20	26	33
S	M6	M8x1	M8x1	M8x1	M8x1	M12x1,5	M12x1,5	M12x1,5	M12x1,5	M16x1,5	M20
T ¹⁾	32	42,5	48,5	47	58	57	72	57,6	71,6	81,6	114
U	18	19,5	25,5	23	34	27	42	22	36	42	63
Jaw approx. kg	0,200	0,435	0,600	0,735	1,400	1,500	3,700	2,265	4,800	4,500	13,350

1) Dimension marked on base jaw

Base jaws **GB**, hardened and ground

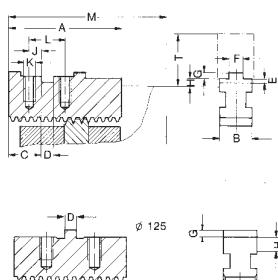

Chuck size	125	160	200	250	315	400+500	630	
A	47	74	90	110	125	160	230	
B	14	20	22	26	32	45	65	
C	21	19	23	26	30	35	52	
D	5	18	20	20	26	30	40	
E	-	5	5,5	5,5	6,5	7,5	9	
F	-	8	10	12	12	18	24	
G	2,8	2,5	3	3	3	4	4	
H	3,55	6	7	7	7,6	8,6	12	
J	7,5	7	10	10	14	15	21	
K	M6	M8x1	M8x1	M12x1,5	M12x1,5	M16x1,5	M20	
L	20	32	40	40	54	60	82	
M	72	103	129	163	196	250	294	399
Jaw approx. kg	0,200	0,265	0,365	0,700	1,065	2,350	5,665	

Chucking capacities DURO-T

Reversible claw-type top jaws
KB, standard design

	Reversible claw-type top jaw, large clamping range			
Chuck size	160	400	500	630
Item no.	137060	137119	137119	151289
Capacities external Ø min. - max.	142,5 - 187,5	314 - 446	311 - 534	391 - 670
Capacities internal Ø min. - max.	22,5 - 67,5	99 - 231	95 - 317	176 - 456
Interfering contour	224	528	592	800

	Reversible claw-type top jaw, small clamping range					
Chuck size	160	200	250	315	400	500
Item no.	137061	137064	137108	137114	137120	137120
Capacities external Ø min. - max.	37,5 - 82,5	56 - 116	90 - 170	82 - 210	142 - 274	139 - 360
Capacities internal Ø min. - max.	133 - 178	160 - 220	177 - 257	242 - 370	301 - 433	266 - 488
Interfering contour	209	264	330	446	535	592

	Reversible claw-type top jaw, medium clamping range					
Chuck size	160	200	250	315	400	500
Item no.	136062	137065	137109	137115	137121	137121
Capacities external Ø min. - max.	103 - 148	117 - 181	167 - 248	178 - 306	270 - 402	267 - 489
Capacities internal Ø min. - max.	71 - 116	91 - 155	100 - 184	97 - 225	142 - 274	139 - 361
Interfering contour	209	264	330	396	504	592

DURO-TA - sealed design

Key bar chucks
DURO-TA



APPLICATION

Specially for grinding machines.
Optimized for extremely high clamping forces, maximum concentricity, as well as reliable long-term repeatability.

TYPE

Key bar chuck with quick-action jaw change system.
Guaranteed maximum jaw precision as far as these are only used on the same chuck, and base and top jaws are kept screwed on for recurring work.

CUSTOMER BENEFITS

- ③ Maximum clamping force thanks to key bar system
- ③ With cover for protection against dust on the face
- ③ Very high jaw-change repeatability

TECHNICAL FEATURES

- With jaw safeguard
- Chuck body completely surface-hardened
- Visual marking for quick jaw adjustment
- External shape incl. splash-water edge
- Fastening options for strongly stressed sliding surfaces
- Incl. safety key
- High corrosion protection

A08
Cylindrical centre mount

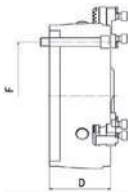

Size	Inch	With base jaws	With inside and outside jaw	D mm	Speed max. min ⁻¹	Max. Torque Nm	Max. total clamping force kN
160	6 1/4	439606	439605	63	5400	120	73
200	8	439608	439607	81	4600	155	114
250	10	439610	439609	92	4200	190	185

Further sizes and mountings available on request

Jaws DURO-TA

A28

Outside jaw DB, set, inward stepped jaw, hardened



Item no.	Chuck Size	Contents of delivery	Jaw width
329041	160	set	20
329042	200	set	22
329043	250	set	26

Additionally or later purchased, hardened jaws must be ground out in the chuck.
For jaws which are applied later, send in the chuck.

A28

Inside jaw BB, set, outward stepped jaw, hardened



Item no.	Chuck Size	Contents of delivery	Jaw width
329038	160	set	20
329039	200	set	22
329040	250	set	26

Additionally or later purchased, hardened jaws must be ground out in the chuck.
For jaws which are applied later, send in the chuck.

A28

Unstepped top jaw AB, set, soft, material 16MnCr5



Item no.	Chuck Size	Contents of delivery	Jaw length	Jaw height	Jaw width
329044	160	set	90	36,5	20,3
329045	200	set	100	40	22
094010	250	set	125	50	30,4

A28

Base jaw GB, set, hardened, with mounting bolts



Item no.	Chuck Size	Contents of delivery	Jaw length	Jaw height	Jaw width
329047	160	set	74	8	20
329048	200	set	90	10	22
329049	250	set	110	12	26

C15

Jaw mounting bolt, 1 piece



Item no.	Chuck Size	Thread	Contents of delivery
200182	160/200	M8x1x22	piece
200183	250	M12x1,5x30	piece

Accessories DURO-TA

Accessories DURO-TA

A08

Base plate with fixing slots

Complete with mounting screws and fixed T-slot nuts. Other sizes available on request.



Item no.	Size
143163	160
143165	200
143167	250

A08

Key



Item no.	Size	Square	L mm
094016	160	10	140
094017	200	12	160
094018	250	14	220

Only for stationary used chucks

A08

Safety key



Item no.	Size	Square	L mm
242173	160	10	140
242174	200	12	160
242175	250	14	220

corresponding with DIN 1550 for rotating chucks

A08

Chip guard, set



Item no.	Size	Contents of delivery
236439	160	set
236440	200	set
236441	250	set

A08

Special grease F80 for lathe chucks

For lubrication and conservation of chucking power



Item no.	Design	Contents
308555	Cartridge	0,5 kg
028975	Tin	1 kg

Technical data DURO-TA

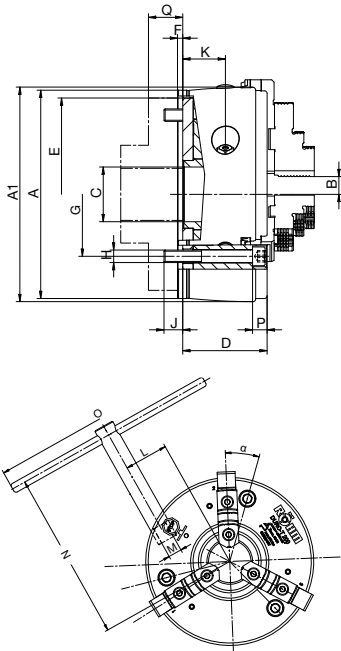

Chuck size		160	200	250
Outer diameter	A	160	206	255
Jaw movement	B	6,2	6,8	8
Bore	C	42	52	62
Bore can be enlarged	C max.	45	55	75
	D	63	81	92
	E ^{H6}	145	185	235
	F	5	5	6
	G	125	160	200
	H	3xM10	3xM12	3xM16
	J	15	18	25
	K	31,5	43	47
	L	42	53,5	66,5
	M	SW10	SW12	SW14
	N	182	211	284
	O	210	270	450
	P	13	14	17
Min. thickness of flange	Q	30	30	35
Moment of inertia ¹⁾	kgm ²	0,03	0,10	0,29
	α	22°	18°	19°
Weight approx	kg	9,5	20°	35

1) The moment of inertia was measured with base jaws but without top jaws or back plate
The bore could be enlarged (measure C, at surcharge)

■ Enlarged bore max.

Max. permissible speed

The maximum permissible speed has been fixed so that 1/3 of the gripping force is still available as residual gripping force if the maximum gripping is applied and the chuck is fitted with its heaviest jaws. The jaws may not project beyond the outside diameter of the chuck. The chuck must be in perfect condition. The specification DIN 6386 Part 1 shall be observed.

Chuck size		160	200	250
Max. speed	min ⁻¹	5400	4600	4200

Gripping force

The gripping force is the sum total of all jaw forces acting radially on the stationary workpiece.
The specified gripping forces are standard values.

They apply to chucks in a perfect condition which have been lubricated with RÖHM grease F79 and F80.

Chuck size		160	200	250
Torque applied on key in1)	Nm	20	30	35
Total gripping force1)	kN	15	24	33
Torque applied on key in	Nm	120	155	190
Max. total gripping force	kN	73	114	185

1) maintaining the accuracy

Chucking capacities of jaw steps

Chuck size		160	200	250	
External chucking	Jaw position.	A1	5-51	7-70	8-97
		A2	45-91	58-123	82-172
		A3	89-135	114-179	-
		A4	115-161	142-207	163-253
Internal chucking		J1	67-105	71-131	99-182
		J2	93-132	99-159	-
		J3	135-174	154-214	178-261

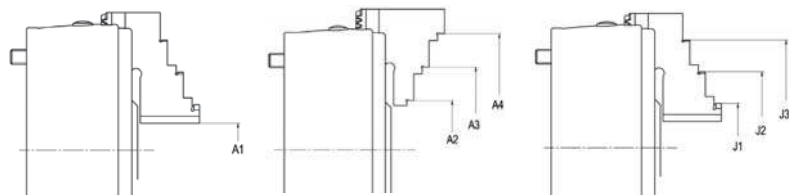
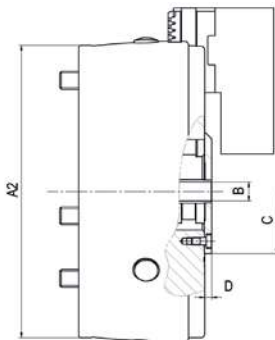

Chuck dimensions DURO-TA - Main dimensions (other dimensions on the table on the top)

Chuck size		160	200	250
Outer diameter	A	160	206	255
External chucking with BB-jaws		3-46	3-60	5-66
External chucking with DB-jaws		23-160	32-200	65-243
Internal chucking with BB jaws		28-156	32-195	47-225
Central bor for coolant	B	13	13	13
	C	70	85	92
	D	5	6	5

Jaw dimensions and chucking capacity DURO-TA

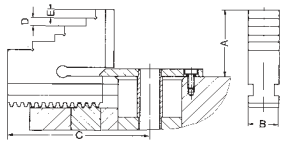

Outward stepped jaw **BB**

Chuck size	160	200	250
A	46	55	60
B	20	22	26
C max.	95	120	143,5
C min.	72	91	113
D	5	7	6
E	6	6	8
Jaw approx. kg	0,465	0,643	1,065

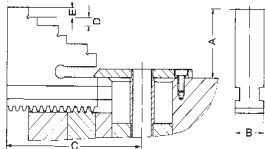

Inward stepped jaw **DB**

Chuck size	160	200	250
A	43	50	50
B	20	22	26
C max.	95	120	143,5
C min.	72	91	113
D	5	7	6
E	6	6	8
Jaw approx. kg	0,435	0,600	1,065

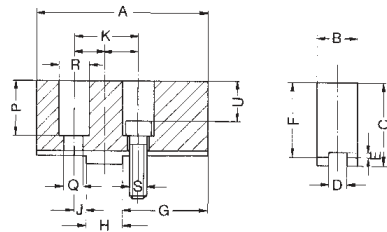

Unstepped soft top jaw **AB**

Chuck size	160	200	250
A	90	100	125
B	20,3	22	30
C	41	45	55
D	8	10	12
E	3	3,5	3,5
F	36,5	40	50
G	55	61	70
H	18	20	20
J	6	6	10
K	30	32	40
P	27,5	31	39
Q	9	9	14
R	15	15	20
S	M8x1	M8x1	M12x1,5
U	19,5	23	27
Jaw approx. kg	0,435	0,800	1,500

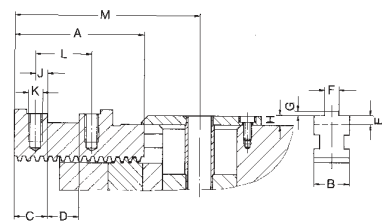

Base jaw **GB**

Chuck size	160	200	250
A	74	90	110
B	20	22	26
C	17	19	26
D	18	20	20
E	5	5,5	5,5
F	8	10	12
G	2,5	7	7
H	6	20	20
J	7	6	10
K	M8x1	M8x1	M12x1,5
L	32	32	40
M max.	105	127	148,5
M min.	91	103	125
Jaw approx. kg	0,335	0,365	0,700

Jaw dimensions and chucking capacity



Notes

DURO-TA XT

Equipped with extended and easy to assemble guideways the new lightweight DURO-TA XT is convincing with a flexible clamping area for machining large and small workpieces. Weight-reducing by up to 75 % makes maximum utilisation of the machine's potential possible.

Guideways

The new DURO-TA XT has an innovative concept for guideways that guarantees flexible and weight-reducing use. In contrast to other large chucks, the DURO-TA XT is up to 75 % lighter and that way makes maximum utilisation of the machine's potential possible and clamping of higher workpiece weights. Through the extended and easy to assemble guideways, the clamping area can be set flexibly and hence converted quickly to large and small workpieces. Through the direct mount on the base body, the guideways guarantee extremely high rigidity, stability and protection against penetration by dirt and dust.

Principle of operation

Thanks to the tangentially arranged threaded spindle, the force is transferred via a key bar having an internal thread. The key bar moves the drive ring via a slide. Two other slides in the drive ring transfer the forces to the other two key bars. The key bars having an inclined profile engage in the base jaws, thereby guaranteeing exact, centric clamping.

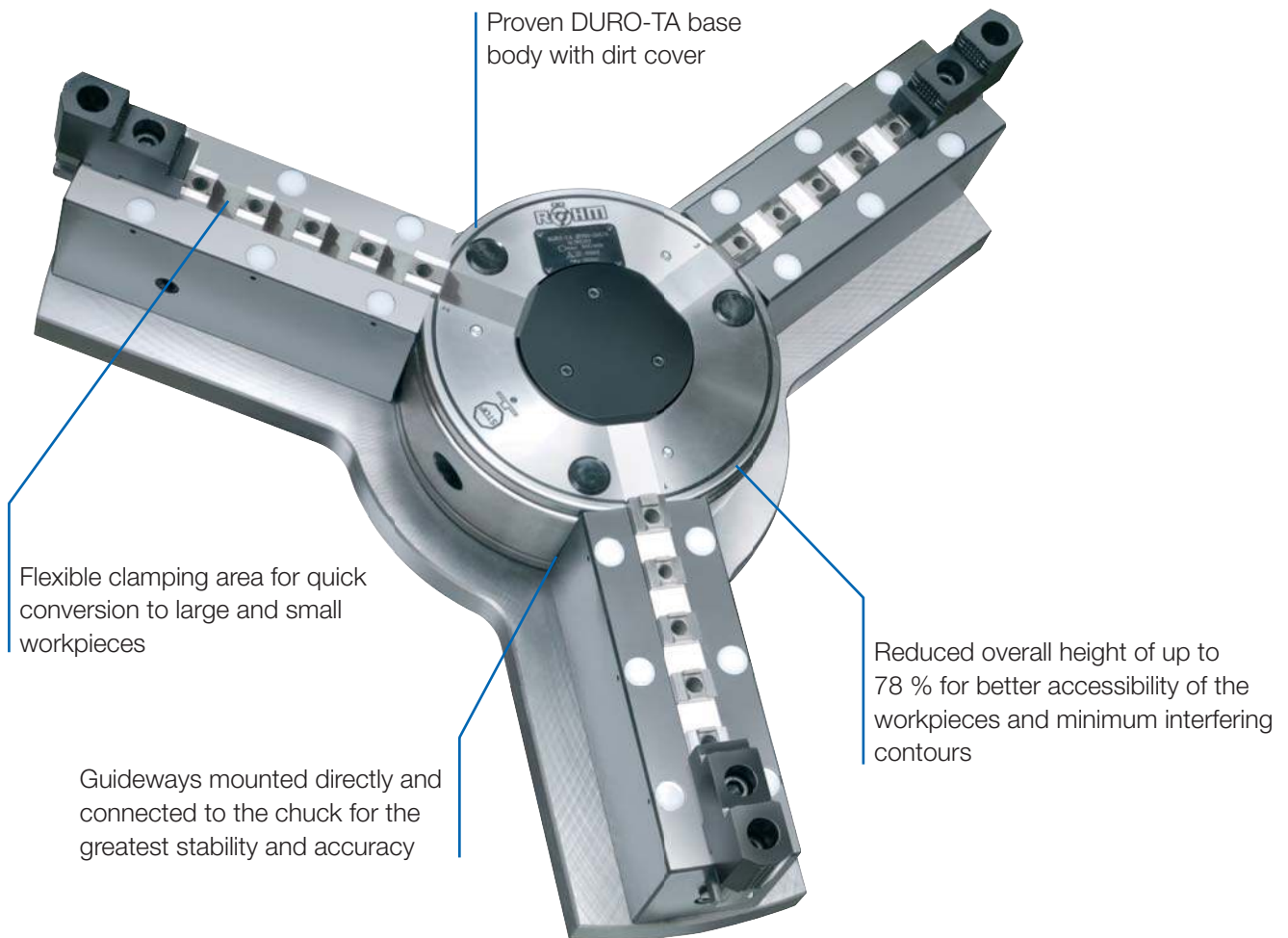

DURO-TA XT



APPLICATION

On turning and milling machines.

TYPE

Key bar chuck (DURO-TA) with removable guideways.

CUSTOMER BENEFITS

- ⊕ Weight reduction by up to 75 %
- ⊕ Maximum flexibility and faster conversion
- ⊕ Innovative design with minimum interference contour and maximum stability

TECHNICAL FEATURES

- Weight reduction by up to 75 % allows maximum utilization of the machine potential and the clamping of heavier workpieces
- Flexible clamping range thanks to elongated guideways for faster conversion between large and small workpieces
- Easy dismounting of the guideways for clamping smaller workpieces
- Minimum interference contour and better workpiece accessibility thanks to compact design and a reduced design height by up to 78 %
- High stability thanks to direct support of the permanently screwed guideways

Key bar chucks
DURO-TA XT

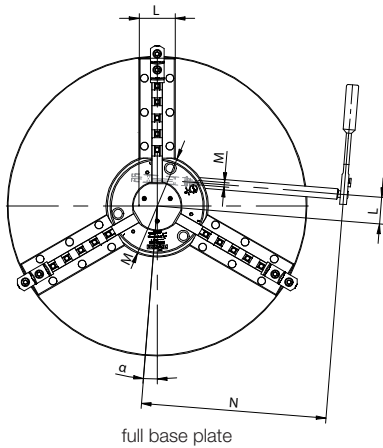

full base plate

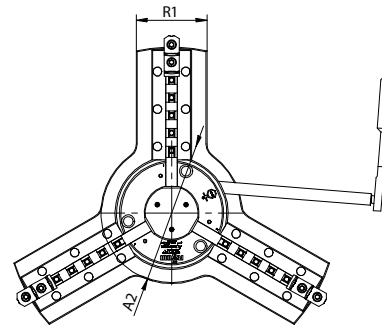

max. lightweight base plate

A08

DURO-TA XT key bar chuck, with complete base plate

Item no.	Size	Clamping range external with extended jaws mm	Clamping range external with standard jaws * mm	Interfering contour ** mm	Jaw travel mm	Weight kg	Speed max. min ⁻¹	Max. Torque Nm	Max. total clamping force kN	Weight reduction compared to a standard chuck %
180312	750 (250)	145-715	8-253	804 / 769	8	183	800	190	185	75
180313	1000 (315)	220-995	12-323	1082 / 1014	10,2	365	570	210	190	68
180314 ▲	1250 (500)	220-1190	40-501	1305	12,5	640	570	320	290	65

Customized adaptations of the base plate for further weight reduction on the machine table on request

* By disassembling of the stripping cap and use of standard reversible jaws

** By shortening of the base jaws. Please consider shorter clamping ranges

Further sizes and mountings available on request

Jaws DURO-TA XT

A28

One-piece jaw EB, set, diagonally tothing, hardened



Item no.	Chuck Size	Contents of delivery	Jaw length	Jaw height	Jaw width
094002	750 (250)	set	114	70	26
094003	1000 (315)	set	130	79	32
094043	1250 (500)	set	167	93	45

Additionally or later purchased, hardened jaws must be ground out in the chuck.
For jaws which are applied later, send in the chuck.
Jaws only usable in basic chuck.

Jaws DURO-TA XT

A28

Unstepped Jaw BL, set, diagonally tothing, unstepped, soft, material 16MnCr5



Item no.	Chuck Size	Contents of delivery	Jaw length	Jaw height	Jaw width
249679	750 (250)	set	118,7	70	26
249680	1000 (315)	set	136,6	79	32
249681	1250 (500)	set	173,6	93	45

Jaws only usable in basic chuck.

A28

Reversible top jaw UB, set, hardened



Item no.	Chuck Size	Contents of delivery	Jaw length	Jaw height	Jaw width
094014	750 (250)	set	92	50	34,4
094015	1000 (315)	set	107	56	35,7
094045	1250 (500)	set	130	72	50,4

Additionally or later purchased, hardened jaws must be ground out in the chuck.
For jaws which are applied later, send in the chuck.
Jaws only usable in basic chuck.

A28

Base jaw GB, set, diagonally tothing, with mounting bolts



Item no.	Chuck Size	Contents of delivery	Jaw length	Jaw width
094006	750 (250)	set	110	26
094007	1000 (315)	set	125	32
094044	1250 (500)	set	160	45

Jaws only usable in basic chuck.

C 21

Draw-down jaws, without clamping inserts, diagonally tothing, 1 piece, without clamping inserts



Item no.	Chuck Size	Jaw length	Jaw height	Jaw width
141041	750 (250)	118,7	58,5	26
141043	1000 (315)	136,4	63,9	32
141045	1250 (500)	173,6	73,4	45

Jaws only usable in basic chuck.

C 21

Draw-down jaws, additional clamping range, for interchangeable clamping inserts, diagonally tothing, 1 piece, without clamping inserts



Item no.	Chuck Size	Jaw length	Jaw height	Jaw width
141042	750 (250)	118,7	58,5	26
141044	1000 (315)	136,4	63,9	32
141048	1250 (500)	173,6	73,4	45

Jaws only usable in basic chuck.

Jaws DURO-TA XT

C 15
Interchangeable clamping inserts, 1 piece, with claws



Item no.	Chuck Size
141052	750 (250) / 1000 (315)
141055	1250 (500)

Jaws only usable in basic chuck.

C 15
Interchangeable clamping inserts, 1 piece, with serrated toothing



Item no.	Chuck Size
141053	750 (250) / 1000 (315)
141056	1250 (500)

Jaws only usable in basic chuck.

C 15
Interchangeable clamping inserts, 1 piece, with heat treatable surface



Item no.	Chuck Size
141054	750 (250) / 1000 (315)
141057	1250 (500)

Jaws only usable in basic chuck.

A28
Reversible top jaw UB, set, hardened



Id.-Nr.	Chuck Size	Contents of delivery	Jaw length	Jaw height	Jaw width
180410	750	set	92	50	34,4
180411	1000	set	107	56	35,7
180412	1250	set	130	72	50,4

Additionally or later purchased, hardened jaws must be ground out in the chuck..
For jaws which are applied later, send in the chuck.

A28
Unstepped top jaw AB, set, standard design, soft, material 16MnCr5



Item no.	Chuck Size	Contents of delivery	Jaw length	Jaw height	Jaw width
094010	250	set	125	50	30,4
094011	315	set	145	50	34,3
094046	400/500	set	180	73	50,5

C 21
Reversible claw-type top jaws, standard design, tongue and groove, large clamping range, 1 piece hardened



Item no.	Chuck Size	Jaw length	Jaw height	Jaw width
137119	400/500	124	62	50

Jaws DURO-TA XT

C 21

Reversible claw-type top jaws, standard design, tongue and groove, middle sized clamping range, 1 piece, hardened



Item no.	Chuck Size	Jaw length	Jaw height	Jaw width
137109	250	72	55	34
137115	315	86	62	34
137121	400/500	100	62	50

C 21

Reversible claw-type top jaws, standard design, tongue and groove, small clamping range, 1 piece, hardened



Item no.	Chuck Size	Jaw length	Jaw height	Jaw width
137108	250	90	55	34
137114	315	100	62	34
137120	400/500	124	62	50

Jaws DURO-TA XT

C 21

Reversible claw-type top jaws, large design, tongue and groove, small clamping range, 1 piece, hardened



Item no.	Chuck Size	Jaw length	Jaw height	Jaw width
137110	250	80	55	50
137116	315	93	62	50

C 21

Reversible claw-type top jaws, large design, tongue and groove, middle sized clamping range, 1 piece, hardened



Item no.	Chuck Size	Jaw length	Jaw height	Jaw width
137112	250	72	55	50
137118	315	86	62	50

C 21

Reversible claw-type top jaws, large design, tongue and groove, large clamping range, 1 piece, hardened



Item no.	Chuck Size	Jaw length	Jaw height	Jaw width
137111	250	90	55	50
137117	315	106	62	50

Accessories DURO-TA XT

C 15

Special grease F80 for lathe chucks
for lubrication and conservation of chucking power



Item no.	Design	Contents
308555	Cartridge	0,5 kg
028975	Tin	1 kg

Technical data DURO-TA XT

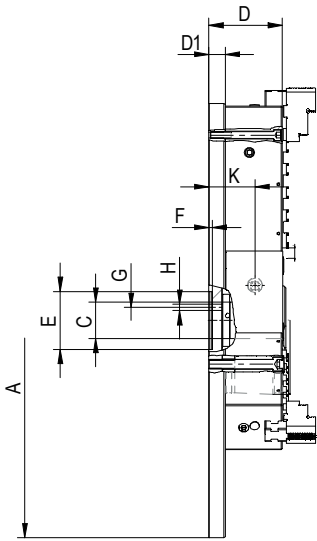

Chuck size A		750	1000	1250
Outer diameter Chuck	A1	256	322	507
Outer diameter Base plate	A2	320	400	590
Jaw movement	B	8	10,2	12,5
Bore ¹⁾	C	62	87	162
	D	127	152	160
	D ¹	28	34	35
	EH6	100	100	100
	F	6	6	6
	G	45	45	45
	H	11	11	11
	K	79,5	98,0	97,5
	L	66,5	86	152,5
	M	SW14	SW17	SW19
	N	464	565	724
	R	90	100	130
	R1	160	180	210
	S	370	495	615
Moment of inertia GD2 ²⁾	kgm ²	10,52	37,92	98,70
Moment of inertia GD2 ^{2) 3)}	kgm ²	5,66	18,10	48,93
	α	4,6°	4,6°	4,5°
approx. kg	kg	183	365	640
approx. kg ³⁾	kg	127	233	436

1) With dirt cover

2) The moment of inertia was measured with base jaws but without top jaws

3) With max. lightweight base plate

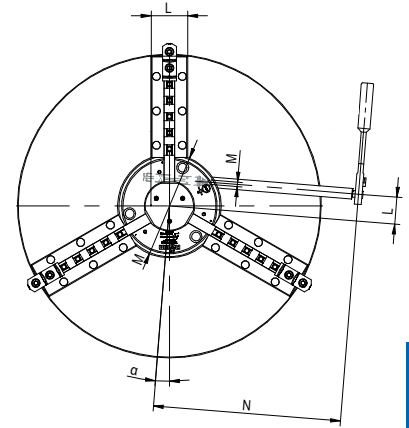

full base plate

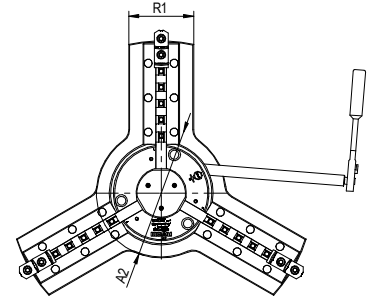

max. lightweight base plate

Max. permissible speed

The maximum permissible speed has been fixed so that 1/3 of the gripping force is still available as residual gripping force if the maximum gripping is applied and the chuck is fitted with its heaviest jaws. The jaws may not project beyond the outside diameter of the chuck. The chuck must be in perfect condition. The specification DIN 6386 Part 1 shall be observed.

Chuck size		750	1000	1250
Max. speed	min ⁻¹	800	570	450

Gripping force

The gripping force is the sum total of all jaw forces acting radially on the stationary workpiece.

The specified gripping forces are standard values.

They apply to chucks in a perfect condition which have been lubricated with RÖHM grease F79 and F80.

Chuck size		750	1000	1250
Torque applied on key 1)	Nm	70	80	100
Total gripping force 1)	kN	66	80	102
Torque applied on key	Nm	190	210	320
Max. total gripping force	kN	185	240	290

1) Maintaining the accuracy

At this torque the clamping jaws have been ground at the factory, for testing the chuck must be clamped with this torque

Chuck capacities of jaw steps

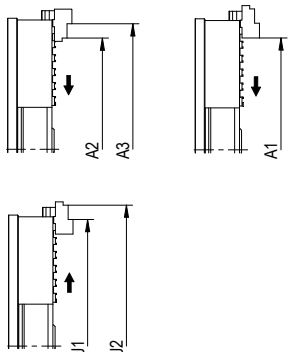

Chuck size		750	1000	1250	
External chucking	Jaw position	A1	144-618	215-864	215-1140
		A2	144-638	330-890	199-1159
		A3	224-719	223-995	340-1200
Internal chucking	Jaw position	J1	227-700	298-946	318-1141
		J2	307-780	404-1052	459-1282
max. interfering contour		808/**773	1086/**1018	1309	

** By shortening of the base jaws. Please consider shorter clamping ranges.

Jaw dimensions DURO-TA XT

Reversible top jaw UB, completely hardened, cross tenon ground, jaw steps not ground

Jaws only usable in basic chuck.

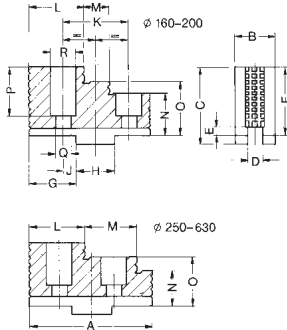

Chuck size	750	1000	1250
A	92	107	130
B	34,4	35,7	50,4
C	55	62	79
D	12	12	18
E	3,5	3,5	4,5
F	50	56	72
G	30	35,5	41,4
H	20	26	30
J	10	14	15
K	40	54	60
L	41	40	51
M	40,5	54	71
N	22	26	32
O	36	41	52
P	39	40	57
Q	14	14	18
R	20	20	26
T ¹⁾	57	63,6	80,6
Jaw approx. kg	0,800	1,135	2,535

1) Dimension marked on base jaw

Unstepped soft top jaw AB, for turning out special chucking diameters

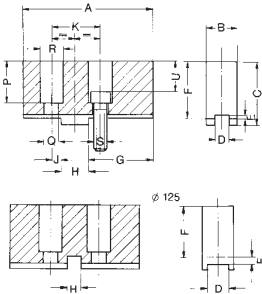

Chuck size	750		1000		1250
A	125	125	145	145	180
B	30,4	50,5	34,3	50,5	50,5
C	55	80	56	80	80
D	12	12	12	12	18
E	3,5	3,5	3,5	3,5	4,5
F	50	75	50	74	73
G	70	70	74	74	100
H	20	20	26	26	30
J	10	10	14	14	15
K	40	40	54	54	60
P	39	54	34	48	58
Q	14	14	14	14	18
R	20	20	20	20	26
S	M12x1,5	M12x1,5	M12x1,5	M12x1,5	M16x1,5
T ¹⁾	57	72	57,6	71,6	81,6
U	27	42	22	36	42
Jaw approx. kg	1,500	3,700	2,265	4,800	4,500

1) Dimension marked on base jaw

Reversible one-piece jaw EB, hardened and ground, jaw steps not ground
Jaws only usable in basic chuck.

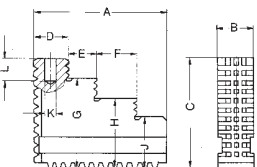

Blockbacken BL, ungestuft, ungehartet, Verzahnung und Fuhrung gehartet und geschliffen. Jaws only usable in basic chuck.

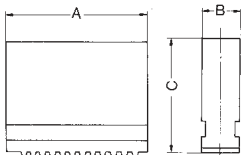

Chuck size	750	1000	1250
A	114	130	167
B	26	32	45
C	70	79	93
D	41,5	40,2	50,5
E	40,3	54	71
F	-	-	-
G	56	64	73
H	-	-	-
J	42	49	53
K	13	13	20
L	19,5	19,5	30
Jaw approx. kg	1,135	1,835	3,665

Chuck size	750	1000	1250
A	118,7	136,6	173,6
B	26	32	45
C	70	79	93
Jaw approx. kg	1,535	2,400	5

Base jaws GB, hardened and ground
Jaws only usable in basic chuck.

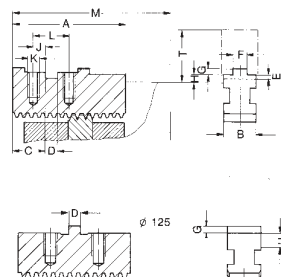

Chuck size	750	1000	1250
A	110	125	160
B	26	32	45
C	26	30	35
D	20	26	30
E	5,5	6,5	7,5
F	12	12	18
G	3	3	4
H	7	7,6	8,6
J	10	14	15
K	M12x1,5	M12x1,5	M16x1,5
L	40	54	60
M	163	196	250 294
Jaw approx. kg	0,700	1,065	2,350