

FTC Front-Mounting Scroll Chuck (Soft and Hard top Jaws)



Application / Benefits

For work requiring through hole
Front mounting holes for convenient installation on lathes and spindles

Technical features

Two-piece, reversible base jaw and top hard jaws (soft top jaws also included)
Self-centering jaws manually opened and closed by t-handle

SPECIFICATIONS

	FTC-165	FTC-190(7")	FTC-230(9")	FTC-273(10")	FTC-310(12")
Max. Static Gripping Force [kN(kgf)]	31(3161)	31(3161)	37(3773)	46(4691)	55(5608)
Clamping Range External [ϕ mm]	3~160	4~180	5~220	5~260	10~300
Clamping Range Internal [ϕ mm]	55~150	56~170	62~210	70~250	86~290
Handle Torque [N · m(kgf · m)]	88(9.0)	107.9(11.0)	147(15.0)	176.5(18.0)	206(21.0)
Max. r.p.m. [min^{-1}]	4000	3500	2900	2500	2200
Weight [kg]	9	12.2	21.2	28	41
Moment of inertia [N · m ² (kg · m ²)]	0.033	0.62(0.063)	1.61(0.163)	2.63(0.265)	5.85(0.588)

	FTC-460(18")	FTC-535(21")	FTC-610(24")	FTC-810(32")	FTC-1000(40")
Max. Static Gripping Force [kN(kgf)]	65(6650)	73(7400)	80(8200)	110(11216)	110(11216)
Clamping Range External [ϕ mm]	40~410	45~481	130~576	270~810	340~990
Clamping Range Internal [ϕ mm]	152~436	155~499	235~592	390~800	450~940
Handle Torque [N · m(kgf · m)]	255.0(26)	313.9(32)	372.7(38)	588(60)	588(60)
Max. r.p.m. [min^{-1}]	1200	950	850	650	470
Weight [kg]	106	182	238	480	780
Moment of inertia [N · m ² (kg · m ²)]	124(12.6)	287(29.3)	488(49.8)	598(61)	598(61)

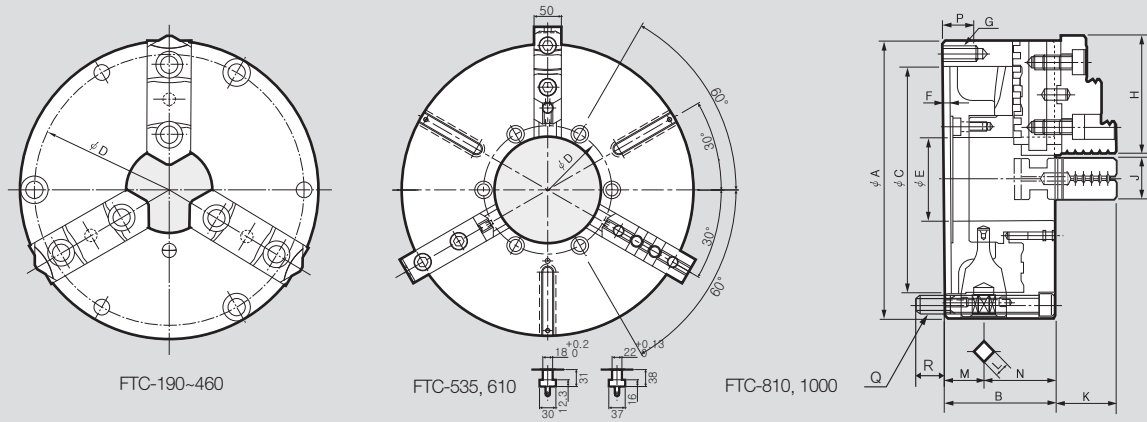

DIMENSIONS

	FTC-165	FTC-190(7")	FTC-230(9")	FTC-273(10")	FTC-310(12")	FTC-460(18")	FTC-535(21")	FTC-610B(24")	FTC-810(32")	FTC-1000(40")
ΦA	167	192	232	273	310	460	535	610	810	1000
B	69	78.7	83.7	88	96	114	143	143	180	196
$\Phi C(H6)$	130	155	190	230	260	400	270	380	520	910
ΦD	147	172	210	250	285	425	235	315	425	510
ΦE	47	57	75	89	100	190	195	275	375	580
F	5	5	6	6	7	8	12	14	16	16
G	3-M10	3-M10	3-M12	3-M12	3-M12	-	-	-	-	-
H	67	80.5	90.5	103.5	115.5	140(130)	150(130)	130	248	286
J	26	28	32	35	40	50	50	50	70	70
K	38.5	42.8	53.8	57.82	56.08	80	82	82	95	95
L	10	11	12	12	14	17	22	22	22	22
M	24	27.5	29.5	31.5	31.5	38.2	57.5	57.5	64	69.5
N	45	51.2	54.2	56.5	64.5	76	85.5	85.5	116	126.5
P	20	20	25	25	25	-	-	-	-	-
Q	3-M10x75	3-M10x90	3-M12x95	3-M12x95	3-M12x110	3-M16x125	3-M20x140	3-M20x140	3-M24x140	3-M24x190
R	17	22	24	20	27	29	32	33	32	35