

Thread Whirling Unit

High Productive Thread Whirling with patented quick change system for significant reduction of tool set-up time.

Suitable insert holders available from leading cutting tool manufacturers.



High Productive Thread Whirling

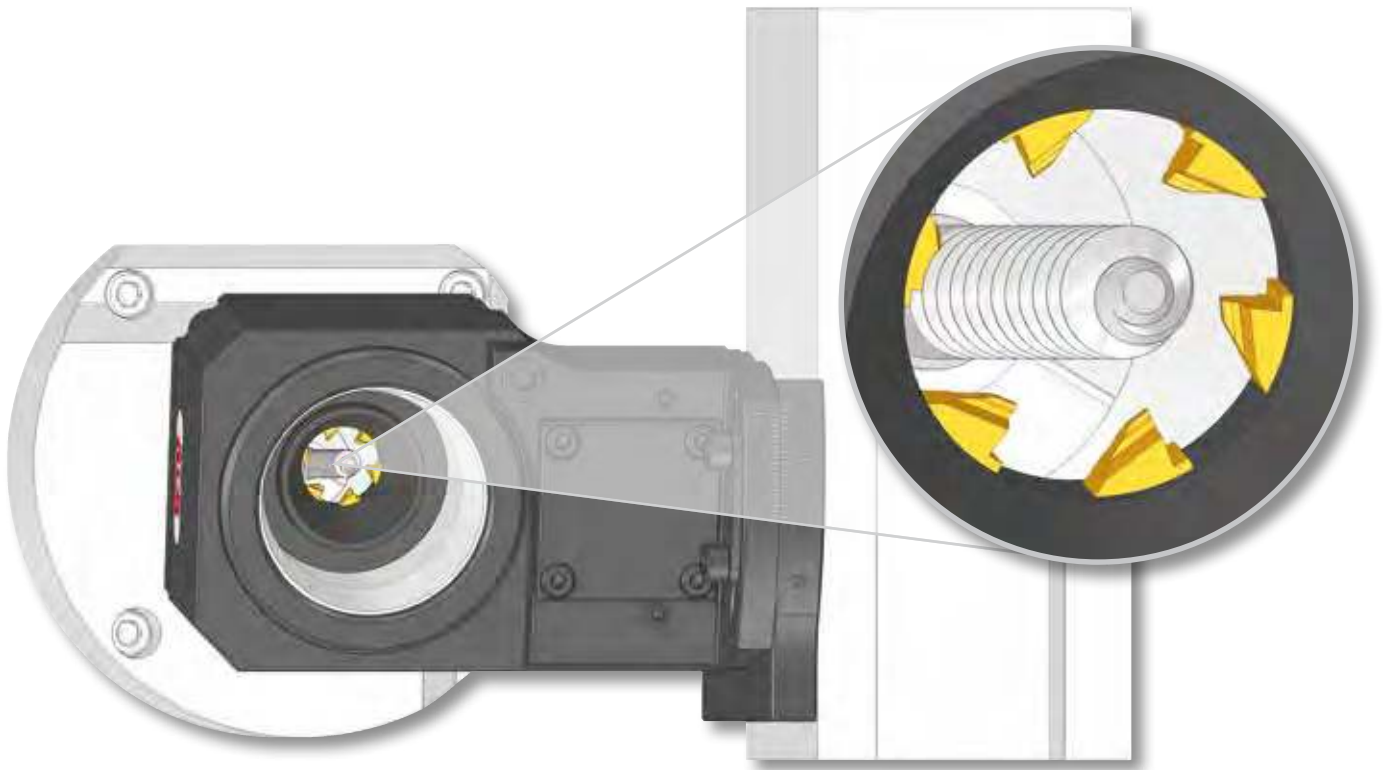

- | Patented quick change system for significant reduction of tool change time
- | The insert holder can quickly be changed from the backside
- | The thread whirling unit can remain installed and aligned in the machine tool
- | Low runout tolerance and high repeatability of the cutting inserts (± 0.005 mm)



Thread whirling unit type 42BJ

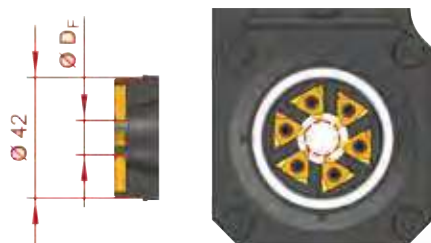

Thread whirling unit type 54BJ

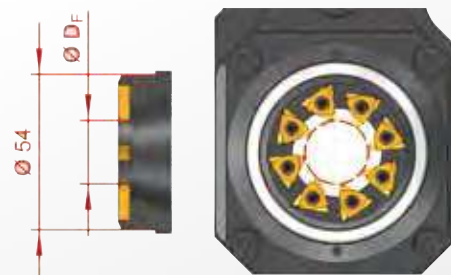

Type 42BJ		Type 54BJ
12 mm	Max. working diameter D_F	22 mm
0 – 20°	Adjustable range α	0 – 30°
4 mm	Max. profile depth t	6 mm
1 : 1	Ratio i ($n1:n2$)	1.36 : 1
8,000 1/min	Max. RPM ($n2$)	6,000 1/min

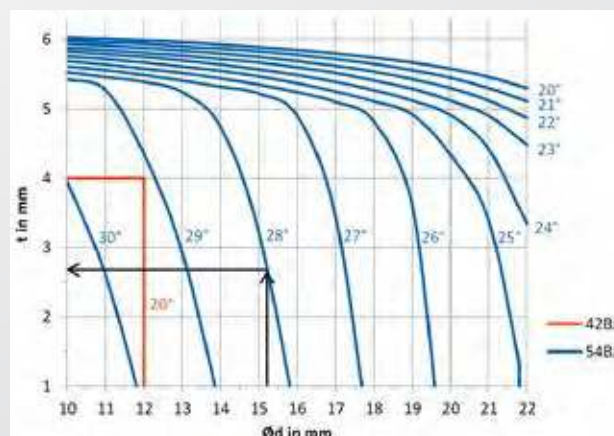
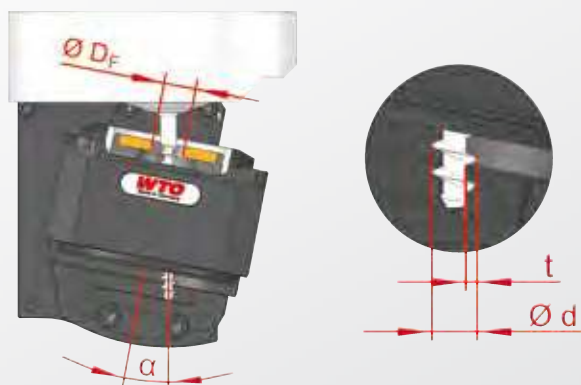

Example type 54BJ: $\varnothing d = 15.2$ mm; $\alpha = 28^\circ$ $t \leq 2.7$ mm

Optional accessories

Sine bar for high accurate angular adjustment

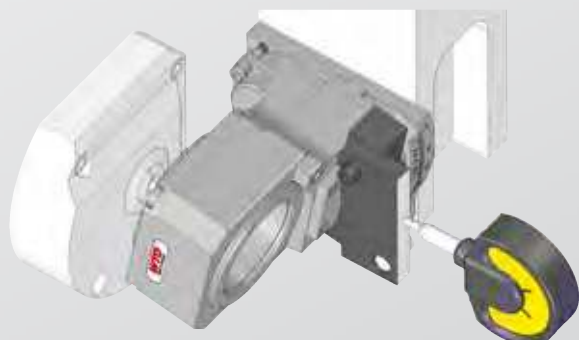

Item No. 96394

External coolant supply

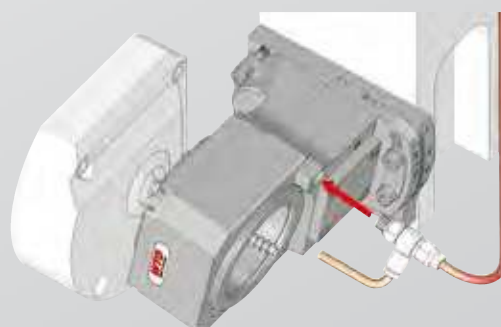

Item No. 91749

Thread whirling unit with insert holder type 42BJ

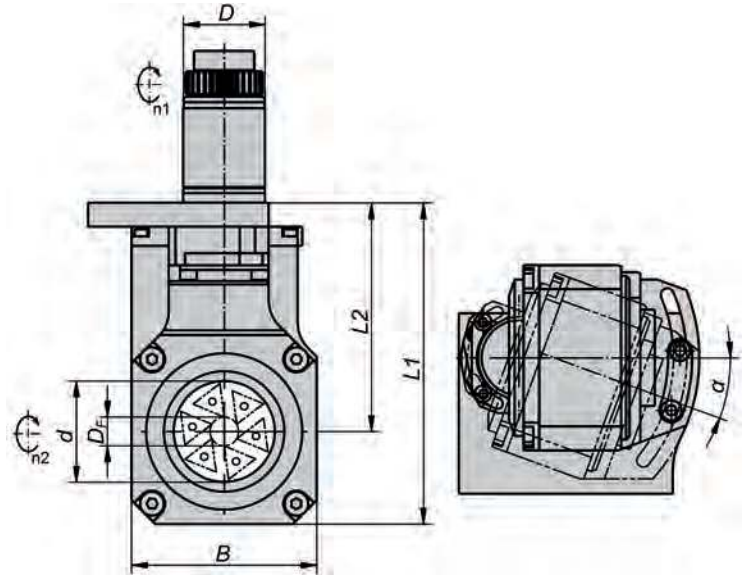

4199... (EC) with external coolant supply

Item No.	Interface		Insert holder dimension		Dimensions/Data					
	ØD	Machine specification	Ød	ØD _f	B	L ₁	L ₂	n 1/min	α	i n1:n2
419942002-34	34	Star SR20R/Star SR32J/Goodway SW20	42	12	77	133.5	95	8000	20°	1:1
419942005-44	44	Star SV20/Star SV32JII (Sub spindle)	42	12	77	133	94	8000	±22°	1:1
419942007-44	44	Star SV20/Star ECAS20T/Star SV32JII	42	12	77	133.5	95	8000	20°	1:1
419942008-44	44	Star SV32/Star ECAS32T	42	12	77	133.5	95	8000	20°	1:1
419942000-32	32	Doosan ST20G/GS	42	12	77	143.5	105	8000	20°	1:1
419942002-32	32	Doosan ST32G/GS/ST35G/GS	42	12	77	143.5	105	8000	20°	1:1
419942004-30	30	Hanwha XD12II	42	12	77	122.5	84	8000	±20°	1:1
419942002-30	30	Hanwha XD20H/XD26H	42	12	77	143.5	105	8000	20°	1:1
419942006-30	30	Hanwha XD20II/XD26II	42	12	77	143.5	105	8000	±15°	1:1
419942000-35	35	Hanwha XDI20	42	12	77	139	100.5	8000	20°	1:1
419942004-32	32	Hanwha XD32H/II /XD35H/II /XD38H/II	42	12	77	143.5	105	8000	±15°	1:1
419942007-30	30	Hanwha STL32H/STL35H/STL38H	42	12	77	143.5	105	8000	±20°	1:1
419942000-39	39	Goodway SW32/SW42	42	12	77	133.5	95	8000	20°	1:1
419942009-30	30	Nexturn SA20/SA26/SA32/SA20XII	42	12	77	153.5	115	8000	20°	1:1
419942003-32	32	Citizen L20	42	12	77	140.5	102	8000	±20°	1:1
419942000-46	46	Tsugami B0265-326/Tsugami SS20-32	42	12	77	143.5	105	8000	20°	1:1
419942001-35	35	Tsugami S205/206	42	12	77	158	119.5	8000	20°	1:1

Dimensions in mm

Suitable insert holders for type 42BJ (order separately)

WTO insert holder interface
TN762004



Item No.
M271.W012.32.09

Item No.
119012

Item No.
224606

Item No.
325-12EE32-16M

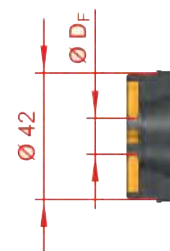

Type 42BJ

Thread whirling unit with insert holder type 54BJ

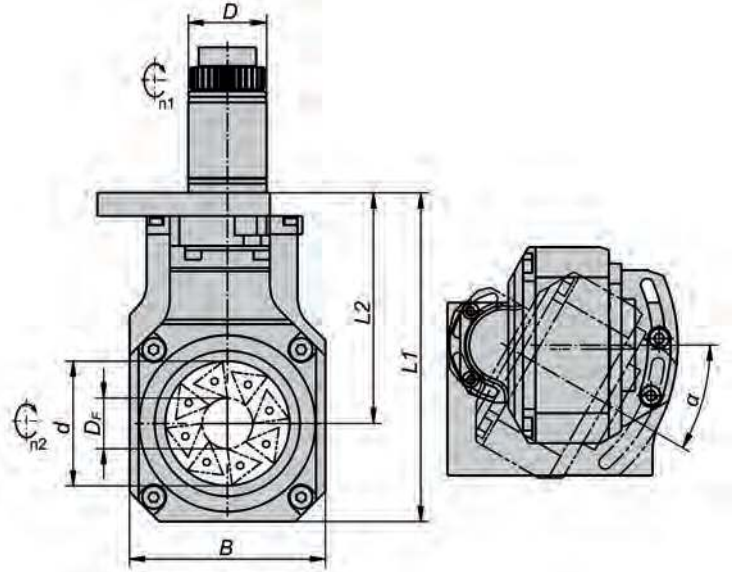

4199... (EC) with external coolant supply

Item No.	Interface		Insert holder dimension		Dimensions/Data					
	ØD	Machine specification	Ød	ØD _F	B	L ₁	L ₂	n 1/min	α	i n1:n2
419954003-34	34	Star SR20R/Star SR32J/Goodway SW20	54	25	85	142.5	100	6000	30°	1,36:1
419954010-44	44	Star SV32/Star ECAS32T	54	25	85	142.5	100	6000	30°	1,36:1
419954006-32	32	Doosan ST20G/GS	54	25	85	152.5	110	6000	30°	1,36:1
419954005-32	32	Doosan ST32G/GS/ST35G/GS	54	25	85	152.5	110	6000	30°	1,36:1
419954011-30	30	Hanwha XD20H/XD26H	54	25	85	152.5	110	6000	30°	1,36:1
419954012-30	30	Hanwha XD20II/XD26II	54	25	85	152.5	110	6000	30°	1,36:1
419954003-35	35	Hanwha XDI20	54	25	85	148	105.5	6000	30°	1,36:1
419954007-32	32	Hanwha XD32H/II /XD35H/II /XD38H/II	54	25	85	152.5	110	6000	30°	1,36:1
419954010-30	30	Nexturn SA20/SA26/SA32/SA20XII	54	25	85	162.5	120	6000	30°	1,36:1
419954001-46	46	Tsugami B0265-326/Tsugami SS20-32	54	25	85	152.5	110	6000	30°	1,36:1
419954002-35	35	Tsugami S205/206	54	25	85	167	124.5	6000	30°	1,36:1

Dimensions in mm

Suitable insert holders for type 54BJ (order separately)

WTO insert holder interface
TN762006

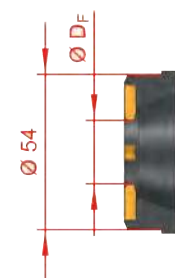

Type 54BJ

Item No.
M271.W022.54.09

Item No.
149508

Item No.
268664

Item No.
325-20EE54-16M

WTO worldwide

WTO
Higher Productivity

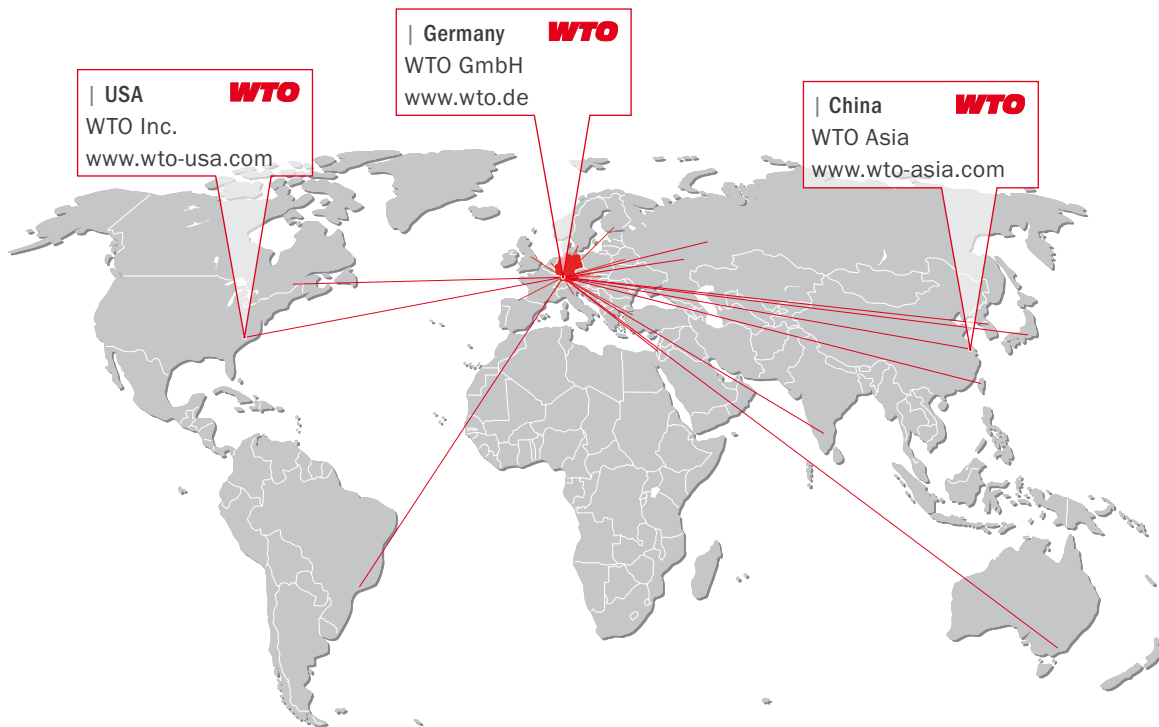

| USA **WTO**
WTO Inc.
www.wto-usa.com

| Germany **WTO**
WTO GmbH
www.wto.de

| China **WTO**
WTO Asia
www.wto-asia.com

WTO GmbH
Auf der oberen Au 45
77797 Ohlsbach
Germany

WTO USA
13900 S Lakes Dr Ste F
Charlotte NC 28273-7119
USA

WTO Asia
Unit 756A, Tower 3
German Center
No. 88 Keyuan Road
Pudong
201203 Shanghai
China

Our distribution partners. Competence right there.

| Australia
Dimac Tooling Ltd.
sales@dimac.com.au

| Finland
Suomen Terätuonti Oy
myynti@stt.as

| Japan
NK Works Co. Ltd.
k_samba@nk-works.co.jp

| Slovakia
ALBA precision s.r.o.
albaprecision@albaprecision.sk

| Belarus
JSC "PMI GROUP"
tool@pmi.by

| France
Société Jung
info@r-jung.com

| Korea
WTO Korea Office
is.chon@wto-korea.com

| Spain
ITALMATIC, S.A.
italmatic@italmatic.es

| Brazil
TF2
tfdois@tfdois.com.br

| France
Utilis France Sàrl
contact@utilis.com

| Mexico
Workholding Engineering De México
info@wem.com.mx

| Sweden
Komet Scandinavia AB
scandinavia@kometgroup.com

| Canada
Mittmann Industrial Inc.
info@mittmann.com

| Great Britain
Cutwel Ltd.
sales@cutwel.net

| Netherlands
Klein Tooling B.V.
verkoop@kleintooling.nl

| Switzerland
Utilis AG
info@utilis.com

| China
Shanghai Gangde
m.wang@wto-asia.com

| India
A.H. Rao
ahr.rao@gmail.com

| Norway
Helge Karlsen Verktøy og Maskin AS
hkvm@hkvm.no

| Taiwan
KAIKO Enterprise Co. Ltd.
info@kaiko.com.tw

| Czech Republic
ALBA precision, spol. s.r.o.
info@albaprecision.cz

| Israel
E.Y.A.R. Ltd.
yehoshua@eyar.co.il

| Russia
Haltec Ltd.
info@haltec.ru

| Turkey
MYK CNC MAKINA SAN. VE
huseyin.tatlidil@mykcnc.com.tr

| Denmark
Tool-part
cj@tool-part.dk

| Italy
Prymark srl
commerciale@prymark.it

| Russia
OTS-Technology Ltd.
sales@otst.ru

| Ukraine
„LLC“ SPA Stankopromimport
info@phoenix-ua.com