

# PT TYPE

## ▶ PT-60 TYPE

- ※ For PIPE machining
- ※ Optimal RPM(below 3,800)

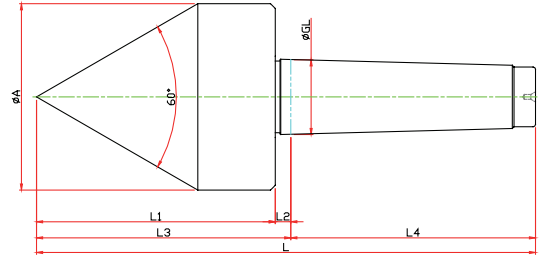

Model	Order Number	Morse Taper	Dimension								Weight MAX.	R.P.M MAX.	Run Out
			GL	A	L1	L2	L3	L4	L				
LC-2PT-60	066002	NO.2	17,780	44	66	5	71	64	135	70	4500	0.003	
LC-3PT-60	066003	NO.3	23,825	56	78,5	5	83,5	81	164,5	80	4500	0.003	
LC-4PT-60	066004	NO.4	31,267	78	100	6,5	106,5	101,5	208	80	4500	0.003	
LC-5PT-60	066005	NO.5	44,399	98	125	6,5	131,5	129,5	261	230	2000	0.005	
LC-6PT-60	066006	NO.6	63,384	118	154	8	162	182	344	600	1500	0.005	

## ▶ PT-80 TYPE

- ※ For PIPE machining
- ※ Optimal RPM(below 3,800)

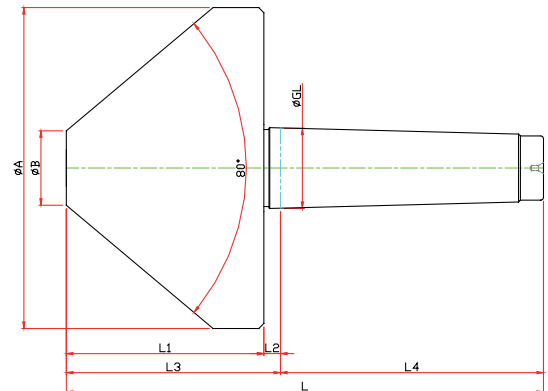

Model	Order Number	Morse Taper	Dimension								Weight MAX.	R.P.M MAX.	Run Out
			GL	A	B	L1	L2	L3	L4	L			
LC-3PT-80	068003	NO.3	23,825	95	20	66	5	65	81	146	190	3800	0.003
LC-4PT-80	068004	NO.4	31,267	125	29	77	6,5	83,5	102,5	185	190	3800	0.003
LC-5PT-80	068005	NO.5	44,399	150	32	90	6,5	96,5	129,5	226	350	2000	0.005
LC-6PT-80	068006	NO.6	63,384	200	38	120	8	128	182	310	1200	1500	0.005