



ZERO POINT SYSTEM
PRECISO, RAPIDO & SICURO - ACCURATE, QUICK & SAFE



MADE IN ITALY



VALIGETTA DI CAMPIONATURA ZERO POINT & MULTITASKING

NEW!

SAMPLE KIT CASE STD ZERO POINT & MULTITASKING

Art. 982

 Valigetta di campionatura morsa Art.640 - Art.665 - Art.81P
 Sample kit case Art.640- Art.665 - Art.81P

Cod. 0.98.20000

All'Interno - Inside:

	Art.10A Art.11A		Art.645T		Art.655J
	Art.645B		Art.640P		Art.370
	Art.645C		Art.655B		Art.375
	Art.645D		Art.655C		Art.376
	Art.645E		Art.655D		Art.377
	Art.645F		Art.655F		Art.297
					Art.298



SIMBOLOGIA DATI TECNICI TECHNICAL DATA ICONS

ZERO POINT ZERO POINT						
	Doppio effetto Double effect	Montaggio multiplo Multiple mounting	Montaggio singolo Single mounting	Carter per piastre interfacciate Carter for interfaced head plates	Montaggio incassato Built-in mounting	Montaggio con flangia Independent mounting
TIRANTI E RIALZI PULL-STUDS AND RISERS						
					Tiranti Pull-stud	Rialzi Risers
POSSIBILITÀ DI POSSIBILITY OF						
				Divisore Automatico Automatic dividing head	Divisore Meccanico Mechanical dividing head	Cubi portapezzi Tombstones
PAGINE PAGES						
					Accessori & Ricambi Accessories & Spare Parts	Istruzioni corretto utilizzo Instruction for a proper use

SISTEMA GERARDI ZERO POINT PNEUMATICO

GERARDI PNEUMATIC ZERO POINT SYSTEM

Il nuovo sistema di posizionamento ed ancoraggio istantaneo Gerardi (Ripetibilità entro 0,005 mm)
The new Gerardi immediate positioning and clamping system (Repositioning accuracy within 0,005 mm)

CARATTERISTICHE E VANTAGGI

- Abbattimento dei tempi di allestimento macchina
- Ottimizzazione della produzione
- Risparmio sulle attrezzature
(su un solo cubo si possono montare diversi tipi di morse)

FEATURES AND ADVANTAGES

- Minimum machine set up times
- Production optimization
- Saving on fixtures
(on the same tombstone you can mount different types of vises)



LA QUALITÀ GERARDI

- Qualità garantita da anni di collaudo nella propria officina
- Start up immediato! Verifica della precisione sui supporti e sulle attrezzature che montano Zero-Point.
- Tutti i componenti sono in acciaio temprato e rettificato
- Ripetibilità entro 0,005 mm
- Pinza elastica integrale per un migliore e più preciso posizionamento e rimozione delle attrezzature

GERARDI QUALITY

- Quality guaranteed by years of tests and real use in our workshop
- Immediate start up! Guarantee of double check on all the fixtures assembled with Zero-Point
- All components made of special alloy of steel case hardened and ground
- Repositioning accuracy within 0,005 mm
- Solid integral elastic collet for a better and more accurate fixtures positioning and disassemble



MONTAGGIO INCASSATO

- Forza di serraggio $5 \div 40$ kN
- Forza di arresto oltre 60kN
- Sbloccaggio ad aria $6 \div 14$ bar
- Cono di posizionamento con pinza elastica
- Doppio centraggio per tirante per massima rigidità
- Pulizia ad aria

BUILT-IN MOUNTING

- Clamping force $5 \div 40$ kN
- Holding force oltre more than 60 kN
- Pneumatic release $6 \div 14$ bar
- Positioning shank with elastic collet
- Double pull-stud centering for Max rigidity
- Air cleaning



LA CONVENIENZA GERARDI

- Unico fornitore per un servizio "CHIAVI IN MANO"
- Piastre, portapezzi e morse modulari predisposte per Zero-Point
- Studio gratuito dell'applicazione
- 1 Anno di garanzia
- Assistenza post vendita
- Tutti i modelli includono il tirante nel prezzo

GERARDI ADVANTAGES

- A unique supplier for a TURNKEY SERVICE
- Head plates, tombstones and modular vises set up for Zero-Point
- Free application study
- 1 year warranty
- After sales service
- One pull stud always included in the standard equipment

RIALZI

Art. 63

RISERS

Art. 63



1 BLOCCETTO DI CONNESSIONE

Bloccetto di connessione con innesto rapido - 1/8" Gas - Art. PN 11

1 CONNECTION BLOCK

Connection block with quick male coupling - 1/8" Gas - Art. PN 11

2 ART.665 TIPO 2 INCASSATO

Zero Point a montaggio incassato, particolarmente adatto per ingombri ridotti. Possibilità di installarli su pallet, piastre e cubi-portapezzi.

2 ART.665 TYPE 2 BUILT-IN

Built-in Zero Point are used with low space requirement. For installation in pallets, plates and tombstones

3 PIASTRA BASE

Piastra base in acciaio o alluminio con 2 Zero Point incassati.

3 BASE PLATE

Steel or alluminum base plate with 2 built-in Zero Point.

4 TIRANTE

Per ancoraggio e posizionamento delle attrezzature o del particolare da lavorare.

4 PULL-STUD

For the clamping and positioning of the fixtures, or directly the workpiece.

5 PNEUMATICO SINGOLO ART.664S

Montaggio con FLANGIA

5 SINGLE PNEUMATIC ART.664S

Mounting with FLANGE

6 PNEUMATICO SINGOLO ART.665S

Montaggio incassato

6 SINGLE PNEUMATIC ART.665S

BUILT-IN mounting



Costi e tempi di attrezzaggio macchina
Costs and times for set up machining centres

95%

Riduzioni dei costi
Cost savings

RIDUZIONE DEL 95% DEI TEMPI DI ATTREZZAMENTO USANDO IL SISTEMA GERARDI ZERO-POINT

Semplicemente posizionando e rimuovendo la morsa / il cubo / il particolare da lavorare sullo Zero-Point in pochi secondi, risparmiando potenzialmente molte ore al giorno.

Drastica riduzione degli scarti.

Il modo più **semplice ed efficace** per ridurre i tempi morti e aumentare i profitti. Ogni operatore può usarlo.

SAVE UP 95% SET UP TIME BY USING ZERO-POINT

Simply place or remove vise / tombstone / workpiece into Zero Point in seconds, potentially saving many hours per day. No more scraps.

The **easiest** and most **cost effective** way to reduce down time and increase profits. Any operator can use it.

ZERO POINT PNEUMATICO MULTIPOLO (Ripetibilità entro 0,005 mm)

MULTIPLE PNEUMATIC ZERO POINT (Repositioning accuracy within 0,005 mm)



Zero Point per serraggio multiplo
 Zero point for multiple clamping

Art. 664



Montaggio con flangia

✓ Forza di serraggio 5 ÷ 40 kN / ✓ Forza di arresto oltre a 60 kN / ✓ Sbloccaggio ad aria 6 ÷ 14bar ✓ Cono di posizionamento con pinza elastica / ✓ Doppio centraggio per tirante per massima rigidità ✓ Pulizia ad aria / ✓ Chiavetta antirotazione

Flange mounting

✓ Clamping force 5 ÷ 40 kN / ✓ Holding force more than 60 kN / ✓ Pneumatic release 6 ÷ 14bar ✓ Positioning shank with elastic collet / ✓ Double pull-stud centering for Max rigidity ✓ Air cleaning / ✓ Antirotation keyway



Art. 665



Montaggio incassato

✓ Forza di serraggio 5 ÷ 40 kN / ✓ Forza di arresto oltre a 60 kN / ✓ Sbloccaggio ad aria 6 ÷ 14 bar ✓ Cono di posizionamento con pinza elastica / ✓ Doppio centraggio per tirante per massima rigidità ✓ Pulizia ad aria / ✓ Chiavetta antirotazione

Built-in mounting

✓ Clamping force 5 ÷ 40 kN / ✓ Holding force more than 60 kN / ✓ Pneumatic release 6 ÷ 14 bar ✓ Positioning shank with elastic collet / ✓ Double pull-stud centering for Max rigidity ✓ Air cleaning / ✓ Antirotation keyway



ZERO POINT PNEUMATICO SINGOLO (Ripetibilità entro 0,005 mm)

SINGLE PNEUMATIC ZERO POINT (Repositioning accuracy within 0,005 mm)

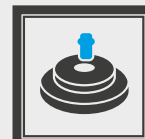

Solo per serraggio tramite un singolo Zero Point con chiavette antirotazione
 Only for single Zero Point clamping with antirotation keyway

Art. 664S



Montaggio con flangia

✓ Forza di serraggio 5 ÷ 40 kN / ✓ Forza di arresto oltre a 60 kN / ✓ Sbloccaggio ad aria 6 ÷ 14 bar ✓ Cono di posizionamento con compensazione assiale / ✓ Doppio centraggio per tirante per massima rigidità ✓ Pulizia ad aria / ✓ 4 Chiavette antirotazione / ✓ Doppio effetto

Flange Mounting

✓ Clamping force 5 ÷ 40 kN / ✓ Holding force more than 60 kN / ✓ Pneumatic release 6÷14 bar ✓ Positioning shank with axial compensation / ✓ Double pull-stud centering for Max rigidity ✓ Air cleaning / ✓ 4 antirotation keyways / ✓ Double effect



Art. 665S



Montaggio incassato

✓ Forza di serraggio 5 ÷ 40 kN / ✓ Forza di arresto oltre a 60 kN / ✓ Sbloccaggio ad aria 6 ÷ 14 bar ✓ Cono di posizionamento con compensazione assiale / ✓ Doppio centraggio per tirante per massima rigidità ✓ Pulizia ad aria / ✓ 4 Chiavette antirotazione

Built-in mounting

✓ Clamping force 5 ÷ 40 kN / ✓ Holding force more than 60 kN / ✓ Pneumatic release 6÷14 bar ✓ Positioning shank with axial compensation / ✓ Double pull-stud centering for Max rigidity ✓ Air cleaning / ✓ 4 antirotation keyways



ZERO POINT PNEUMATICO

PNEUMATIC ZERO POINT

Lo Zero-point è il sistema PNEUMATICO di posizionamento e ancoraggio istantaneo, rappresenta la soluzione ideale per il posizionamento ed il serraggio preciso, rapido e sicuro delle attrezzature sul pallet delle macchine utensili.

Lo Zero-point è un sistema "NORMALMENTE CHIUSO", utilizza molle che permettono il bloccaggio del tirante mediante le sfere poste all' interno mentre l' aria compressa, filtrata e lubrificata, serve per lo sbloccaggio dando così una maggiore sicurezza in fase di lavoro.

The Zero-point is an immediate pneumatic positioning and clamping system, that represents the ideal solution for the positioning and the precise, fast and firm clamping of the equipments on the machine tools.

The Zero-point is a system "NORMALLY CLOSED", that uses die springs allowing the clamping of the pull-stud through the spheres located inside, while the filtered and lubricated compressed air enables the release and a bigger security in working process.

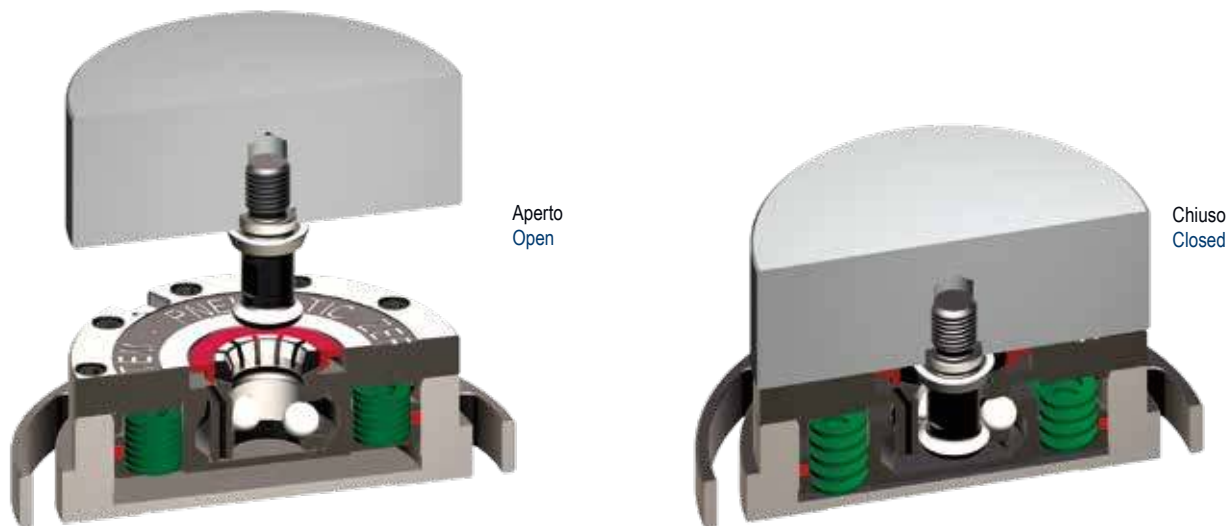

DISPOSIZIONE DEI TIRANTI DI BLOCCAGGIO

ARRANGEMENT OF PULL-STUD CLAMPING

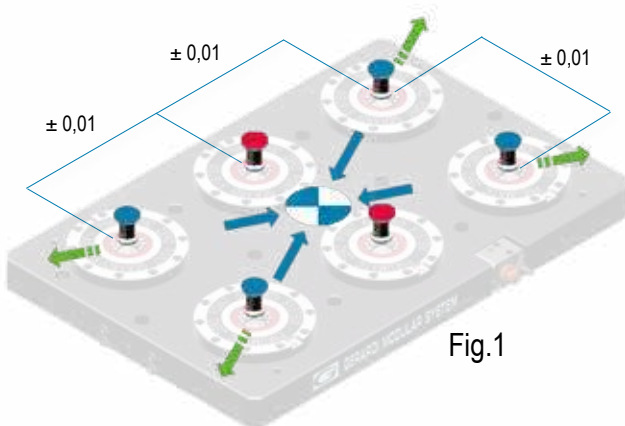



Fig.1

Disposizione dei tiranti con Zero Point multipli

Alignment of pull-studs with multiple Zero Point

Il sistema zero-point multiplo (art.664-665) grazie alla pinza elastica integrale consente una traslazione laterale che compensa errori di interassi e variazioni dovute alla temperatura. Il punto di riferimento centrale rimane costante ed è corretto utilizzare tiranti di posizionamento fino ad un massimo di 4 alternati a tiranti di solo bloccaggio. (Vedi Fig.1)

The multiple zero-point system (art.664-665) allows thanks to the solid integral elastic collet a lateral translation, that solves problems of centre distances and variations caused by the temperature. The central reference point remains steady and it is correct to use positioning pull-studs, up to maximum 4 to interchange with clamping pull-studs. (See picture 1)

 Perno tirante di centraggio.
Centering pull-stud.

 Perno tirante
Pull-stud

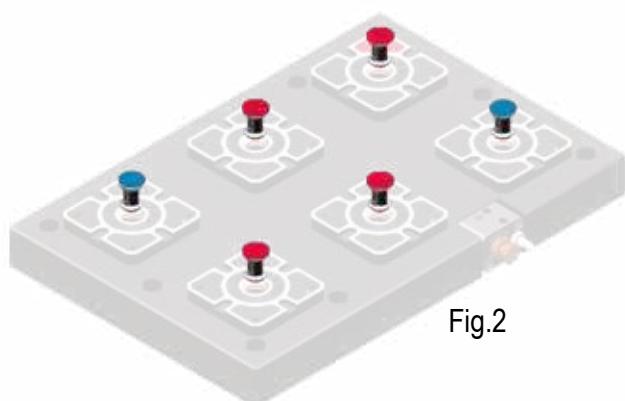

Fig.2

Disposizione dei tiranti con Zero Point singolo

Alignment of pull-studs with single Zero Point

Il sistema zero-point singolo (art.664S-665S) non permettono una traslazione laterale, necessita di 2 tiranti di posizionamento massimo, alternati a tiranti di solo bloccaggio. (Vedi Fig.2)

The single zero point system (art.664S-665S) doesn't enable a lateral translation, there for it needs maximum 2 pull-studs, alternated to clamping pull-studs. (See picture 2)

 Perno tirante di centraggio.
Centering pull-stud.

 Perno tirante
Pull-stud

Tipo (grandezza) Zero-Point Zero-Point type (size)	kN	1 up to 14 kN	
Pressione apertura / Opening pressure	BAR	7 ÷ 14	
Art. 664 	ZERO-POINT pneumatico montaggio con FLANGIA Pneumatic ZERO-POINT FLANGE mounting	A	Ø138
		B	90
		C	30
		D	20
	Forma Shape		
	kg	2,7	
	Cod.	9.66.41000	

EXTRA, chiavette o fori calibrati su richiesta
EXTRA keyways or calibrated holes on request

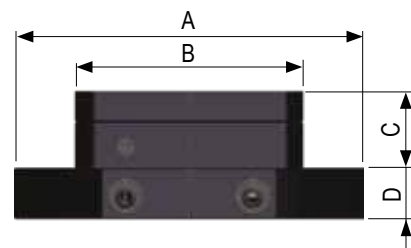

- Dotazione standard - Standard equipment:**
- 1 tirante Art.11A
 - 1 tappo teflon con O-Ring Art.9
 - 1 Pull-stud Art.11A
 - Teflon cap with O-Ring Art.9

Tipo (grandezza) Zero-Point Zero-Point type (size)	kN	2 up to 18 kN	
Pressione apertura / Opening pressure	BAR	7 ÷ 14	
Art. 664 	ZERO-POINT pneumatico montaggio con FLANGIA Pneumatic ZERO-POINT FLANGE mounting	A	Ø178
		B	Ø138 h7
		C	35
		D	20
	Forma Shape		
	kg	6	
	Cod.	9.66.42000	

EXTRA chiavette o fori calibrati su richiesta
EXTRA keyways or calibrated holes on request

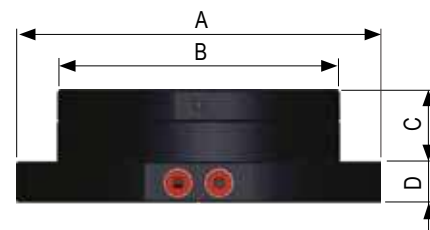

- Dotazione standard - Standard equipment:**
- 1 tirante Art.11A
 - 1 tappo teflon con O-Ring Art.9
 - 1 Pull-stud Art.11A
 - Teflon cap with O-Ring Art.9

Tipo (grandezza) Zero-Point Zero-Point type (size)	kN	3 up to 40 kN	
Pressione apertura / Opening pressure	BAR	7 ÷ 14	
Art. 664 NEW! 	ZERO-POINT pneumatico montaggio con FLANGIA Pneumatic ZERO-POINT FLANGE mounting	A	Ø213
		B	Ø168 h7
		C	45
		D	25
	Forma Shape		
	kg	11,2	
	Cod.	9.66.43000	

EXTRA chiavette o fori calibrati su richiesta
EXTRA keyways or calibrated holes on request

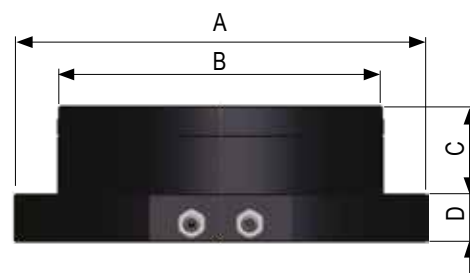

- Dotazione standard - Standard equipment:**
- 1 tirante Art.11A
 - 1 tappo teflon con O-Ring Art.9
 - 1 Pull-stud Art.11A
 - Teflon cap with O-Ring Art.9

AMPLIA LE TUE APPLICAZIONI TRAMITE GLI ACCESSORI MODULARI !

Art. 408
Moltiplicatore di pressione aria
Pressure air multiplier



Cod. 9.40.80000

Art. 399
Gruppo filtro riduttore più lubrificatore
Compressed air preparation unit



Cod. 4.39.90000

Art. 10A TIPO 1 / TYPE 1 Perno tirante di centraggio . Filetto femmina <i>Centering pull-stud. Female thread</i>		Art. 10B TIPO 1 / TYPE 1 Perno tirante . Filetto femmina <i>Clamping pull-stud. Female thread</i>		Art. 11A TIPO 1 / TYPE 1 Perno tirante di centraggio . Filetto maschio <i>Centering pull-stud. Male thread</i>		Art. 11B TIPO 1 / TYPE 1 Perno tirante . Filetto maschio <i>Clamping pull-stud. Male thread</i>	
Cod.	9.10.A1000	Cod.	9.10.B1000	Cod.	9.11.A1000	Cod.	9.11.B1000

Art. 10A TIPO 2 / TYPE 2 Perno tirante di centraggio . Filetto femmina <i>Centering pull-stud. Female thread</i>		Art. 10B TIPO 2 / TYPE 2 Perno tirante . Filetto femmina <i>Clamping pull-stud. Female thread</i>		Art. 11A TIPO 2 / TYPE 2 Perno tirante di centraggio . Filetto maschio <i>Centering pull-stud. Male thread</i>		Art. 11B TIPO 2 / TYPE 2 Perno tirante . Filetto maschio <i>Clamping pull-stud. Male thread</i>	
Cod.	9.10.A2000	Cod.	9.10.B2000	Cod.	9.11.A2000	Cod.	9.11.B2000

Art. 10A NEW! TIPO 3 / TYPE 3 Perno tirante di centraggio . Filetto femmina <i>Centering pull-stud. Female thread</i>		Art. 10B NEW! TIPO 3 / TYPE 3 Perno tirante . Filetto femmina <i>Clamping pull-stud. Female thread</i>		Art. 11A NEW! TIPO 3 / TYPE 3 Perno tirante di centraggio . Filetto maschio <i>Centering pull-stud. Male thread</i>		Art. 11B NEW! TIPO 3 / TYPE 3 Perno tirante . Filetto maschio <i>Clamping pull-stud. Male thread</i>	
Cod.	9.10.A3000	Cod.	9.10.B3000	Cod.	9.11.A3000	Cod.	9.11.B3000

UPGRADE YOUR VISE APPLICATIONS THROUGH MODULAR ACCESSORIES !

Art. 402/90

 Distributore leva angolare 90°, 3 vie
 90° angular valve, 3 ways



Cod. 9.40.29000

Art. PN11

 Blocchetto di connessione
 con innesto rapido - 1/8" Gas
 Connection block
 with quick male coupling - 1/8" Gas

Cod. 9.PN.11000

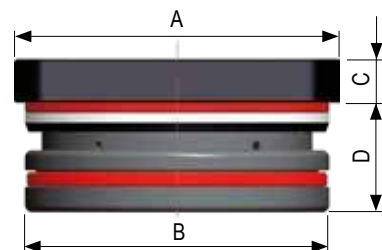
Tipo (grandezza) Zero-Point Zero-Point type (size)		1 up to 14 kN	
Pressione apertura / Opening pressure	BAR	7 ÷ 14	
Art. 665	ZERO-POINT pneumatico montaggio incassato	A	90
	Pneumatic ZERO-POINT built-in mounting	B	Ø84
		C	12
		D	30
	Forma Shape		
	kg	1,5	
	Cod.	9.66.51000	

 EXTRA, chiavette o fori calibrati su richiesta
 EXTRA keyways or calibrated holes on request

- Dotazione standard - Standard equipment:**
- 1 tirante Art. 11A
 - 1 tappo teflon con O-Ring Art.9
 - 1 Pull-stud Art. 11A
 - Teflon cap with O-Ring Art.9

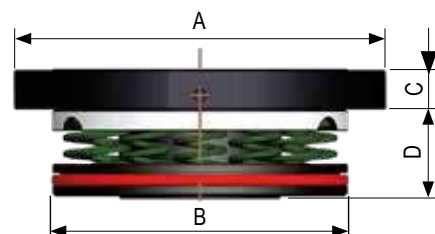

Tipo (grandezza) Zero-Point Zero-Point type (size)		2 up to 18 kN	
Pressione apertura / Opening pressure	BAR	7 ÷ 14	
Art. 665	ZERO-POINT pneumatico montaggio incassato	A	Ø138
	Pneumatic ZERO-POINT built-in mounting	B	Ø110 h7
		C	15
		D	33
	Forma Shape		
	kg	2,5	
	Cod.	9.66.52000	

 EXTRA chiavette o fori calibrati su richiesta
 EXTRA keyways or calibrated holes on request

- Dotazione standard - Standard equipment:**
- 1 tirante Art. 11A
 - 1 tappo teflon con O-Ring Art.9
 - 1 Pull-stud Art. 11A
 - Teflon cap with O-Ring Art.9

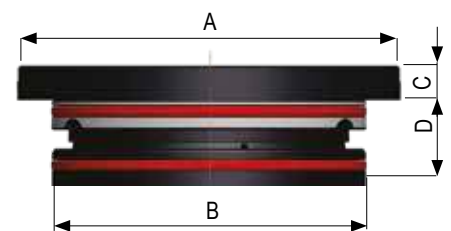

Tipo (grandezza) Zero-Point Zero-Point type (size)		3 up to 40 kN	
Pressione apertura / Opening pressure	BAR	7 ÷ 14	
Art. 665	ZERO-POINT pneumatico montaggio incassato	A	Ø168
	Pneumatic ZERO-POINT built-in mounting	B	Ø138 h7
		C	15
		D	47
	Forma Shape		
	kg	5,8	
	Cod.	9.66.53000	

 EXTRA chiavette o fori calibrati su richiesta
 EXTRA keyways or calibrated holes on request

- Dotazione standard - Standard equipment:**
- 1 tirante Art. 11A
 - 1 tappo teflon con O-Ring Art.9
 - 1 Pull-stud Art. 11A
 - Teflon cap with O-Ring Art.9

AMPLIA LE TUE APPLICAZIONI TRAMITE GLI ACCESSORI MODULARI !

Art. 408

Moltiplicatore di pressione aria
Pressure air multiplier

Vedi Pag - See Page 9.19

Cod. 9.40.80000

Art. 399

Gruppo filtro riduttore più lubrificatore
Compressed air preparation unit

Vedi Pag - See Page 9.39

Cod. 4.39.90000

Art. 10A TIPO 1 / TYPE 1 Perno tirante di centraggio . Filetto femmina Centering pull-stud. Female thread  <p>Pag - Page 9.34</p>	Art. 10B TIPO 1 / TYPE 1 Perno tirante . Filetto femmina Clamping pull-stud. Female thread  <p>Pag - Page 9.34</p>	Art. 11A TIPO 1 / TYPE 1 Perno tirante di centraggio . Filetto maschio Centering pull-stud. Male thread  <p>Pag - Page 9.34</p>	Art. 11B TIPO 1 / TYPE 1 Perno tirante . Filetto maschio Clamping pull-stud. Male thread  <p>Pag - Page 9.34</p>
Cod. 9.10.A1000	Cod. 9.10.B1000	Cod. 9.11.A1000	Cod. 9.11.B1000

Art. 10A TIPO 2 / TYPE 2 Perno tirante di centraggio . Filetto femmina Centering pull-stud. Female thread  <p>Pag - Page 9.35</p>	Art. 10B TIPO 2 / TYPE 2 Perno tirante . Filetto femmina Clamping pull-stud. Female thread  <p>Pag - Page 9.35</p>	Art. 11A TIPO 2 / TYPE 2 Perno tirante di centraggio . Filetto maschio Centering pull-stud. Male thread  <p>Pag - Page 9.35</p>	Art. 11B TIPO 2 / TYPE 2 Perno tirante . Filetto maschio Clamping pull-stud. Male thread  <p>Pag - Page 9.35</p>
Cod. 9.10.A2000	Cod. 9.10.B2000	Cod. 9.11.A2000	Cod. 9.11.B2000

Art. 10A NEW! TIPO 3 / TYPE 3 Perno tirante di centraggio . Filetto femmina Centering pull-stud. Female thread  <p>Pag - Page 9.36</p>	Art. 10B NEW! TIPO 3 / TYPE 3 Perno tirante . Filetto femmina Clamping pull-stud. Female thread  <p>Pag - Page 9.36</p>	Art. 11A NEW! TIPO 3 / TYPE 3 Perno tirante di centraggio . Filetto maschio Centering pull-stud. Male thread  <p>Pag - Page 9.36</p>	Art. 11B NEW! TIPO 3 / TYPE 3 Perno tirante . Filetto maschio Clamping pull-stud. Male thread  <p>Pag - Page 9.36</p>
Cod. 9.10.A3000	Cod. 9.10.B3000	Cod. 9.11.A3000	Cod. 9.11.B3000

UPGRADE YOUR VISE APPLICATIONS THROUGH MODULAR ACCESSORIES !

Art. 402/90

Distributore leva angolare 90, 3 vie
 90° angular valve, 3 ways
 Vedi Pag - See Page 9.39



Cod. 9.40.29000

Art. PN11

Blocchetto di connessione
 con innesto rapido - 1/8" Gas
 Connection block
 with quick male coupling - 1/8" Gas
 Vedi Pag - See Page 9.3



Cod. 9.PN.11000

Tipo (grandezza) Zero-Point Zero-Point type (size)	kN	1 up to 14 kN
Pressione apertura / Opening pressure	BAR	7 ÷ 14
Art. 664S ZERO-POINT pneumatico SINGOLO montaggio con flangia SINGLE pneumatic ZERO-POINT flange mounting	A	Ø138
	B	90
	C	30
	D	20
	Forma Shape	
kg		2,7
Cod.		9.66.4S100



4 chiavette comprese nel prezzo
4 keyways included in the price

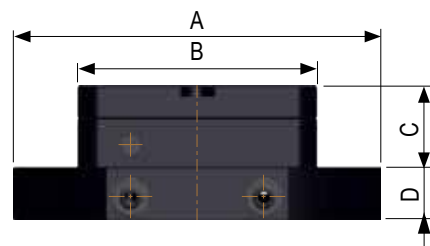

Dotazione standard - Standard equipment:

- 1 tirante Art.11A
- 1 tappo teflon con O-Ring Art.9
- 1 Pull-stud Art.11A
- Teflon cap with O-Ring Art.9

Tipo (grandezza) Zero-Point Zero-Point type (size)	kN	2 up to 25 kN
Pressione apertura / Opening pressure	BAR	7 ÷ 14
Art. 664S ZERO-POINT pneumatico SINGOLO montaggio con flangia SINGLE pneumatic ZERO-POINT flange mounting	A	Ø188
	B	120
	C	45
	D	20
	Forma Shape	
kg		6,5
Cod.		9.66.4S200

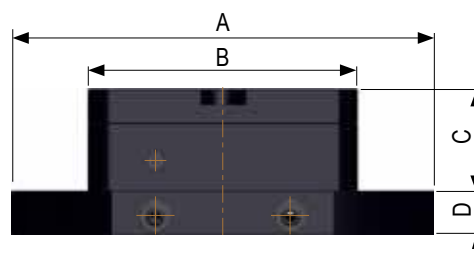

4 chiavette comprese nel prezzo
4 keyways included in the price



Dotazione standard - Standard equipment:

- 1 tirante Art.11S
- 1 tappo teflon con O-Ring Art.9
- 1 Pull-stud Art.11S
- Teflon cap with O-Ring Art.9

Tipo (grandezza) Zero-Point Zero-Point type (size)	kN	3 up to 39,5 kN
Pressione apertura / Opening pressure	BAR	7 ÷ 14
Art. 664S NEW! ZERO-POINT pneumatico SINGOLO montaggio con flangia SINGLE pneumatic ZERO-POINT flange mounting	A	Ø215
	B	Ø168
	C	45
	D	25
	Forma Shape	
kg		11
Cod.		9.66.4S300

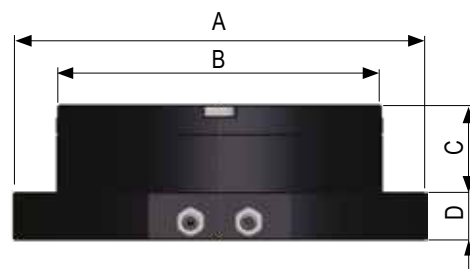

4 chiavette comprese nel prezzo
4 keyways included in the price

Dotazione standard - Standard equipment:

- 1 tirante Art.11A
- 1 tappo teflon con O-Ring Art.9
- 1 Pull-stud Art.11A
- Teflon cap with O-Ring Art.9

AMPLIA LE TUE APPLICAZIONI TRAMITE GLI ACCESSORI MODULARI !

Art. 408
Moltiplicatore di pressione aria
Pressure air multiplier

Cod. 9.40.80000

Vedi Pag - See Page 9.19

Art. 399
Gruppo filtro riduttore più lubrificatore
Compressed air preparation unit

Cod. 4.39.90000

Vedi Pag - See Page 9.39

Art. 10A
TIPO 1 / TYPE 1

 Perno tirante di **centraggio**. Filetto femmina
 Centering pull-stud. Female thread

 Pag - Page
 9.34

Cod. 9.10.A1000

Art. 11A
TIPO 1 / TYPE 1

 Perno tirante di **centraggio**. Filetto maschio
 Centering pull-stud. Male thread

 Pag - Page
 9.34

Cod. 9.11.A1000

Art. 10S
TIPO 2 / TYPE 2

 Perno tirante di **centraggio** per Zero Point **singolo**. Filetto femmina
 Centering pull-stud for **single** Zero Point. Female thread

 Pag - Page
 9.35

Cod. 9.10.S2000

Art. 11S
TIPO 2 / TYPE 2

 Perno tirante di **centraggio** per Zero Point **singolo**. Filetto maschio
 Centering pull-stud for **single** Zero Point. Male thread

 Pag - Page
 9.35

Cod. 9.11.S2000

Art. 10A
NEW!
TIPO 3 / TYPE 3

 Perno tirante di **centraggio** per Zero Point **singolo**. Filetto femmina
 Centering pull-stud for **single** Zero Point. Female thread

 Pag - Page
 9.36

Cod. 9.10.A3000

Art. 11A
NEW!
TIPO 3 / TYPE 3

 Perno tirante di **centraggio** per Zero Point **singolo**. Filetto maschio
 Centering pull-stud for **single** Zero Point. Male thread

 Pag - Page
 9.36

Cod. 9.11.A3000

UPGRADE YOUR VISE APPLICATIONS THROUGH MODULAR ACCESSORIES !

Art. 402/90

 Distributore leva angolare 90, 3 vie
 90° angular valve, 3 ways

Vedi Pag - See Page 9.39



Cod. 9.40.29000

Art. PN11

 Blocchetto di connessione
 con innesto rapido - 1/8" Gas
 Connection block
 with quick male coupling - 1/8" Gas

Vedi Pag - See Page 9.3



Cod. 9.PN.11000

Tipo (grandezza) Zero-Point Zero-Point type (size)		1 up to 14 kN
Pressione apertura / Opening pressure	BAR	7 ÷ 14
Art. 665S ZERO-POINT pneumatico SINGOLO montaggio incassato SINGLE pneumatic ZERO-POINT built-in mounting	A	∅90
	B	∅84 h7
	C	12
	D	30
Forma Shape		
kg		1,5
Cod.		9.66.5S100

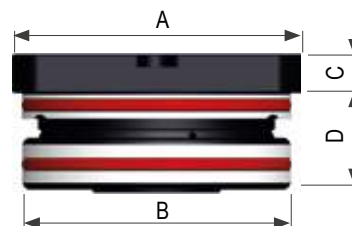
 Chiavette comprese nel prezzo
 keyways included in the price

Dotazione standard - Standard equipment:

- 1 tirante Art.11A
- 1 tappo teflon con O-Ring Art.9
- 1 Pull-stud Art.11A
- Teflon cap with O-Ring Art.9

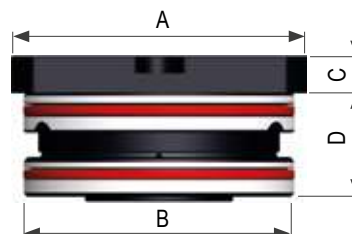
Tipo (grandezza) Zero-Point Zero-Point type (size)		2 up to 25 kN
Pressione apertura / Opening pressure	BAR	7 ÷ 14
Art. 665S ZERO-POINT pneumatico SINGOLO montaggio incassato SINGLE pneumatic ZERO-POINT built-in mounting	A	∅120
	B	∅110 h7
	C	15
	D	42
Forma Shape		
kg		2,5
Cod.		9.66.5S200

 Chiavette comprese nel prezzo
 keyways included in the price

Dotazione standard - Standard equipment:

- 1 tirante Art.11S
- 1 tappo teflon con O-Ring Art.9
- 1 Pull-stud Art.11S
- Teflon cap with O-Ring Art.9

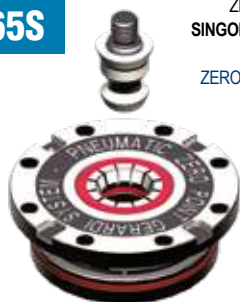
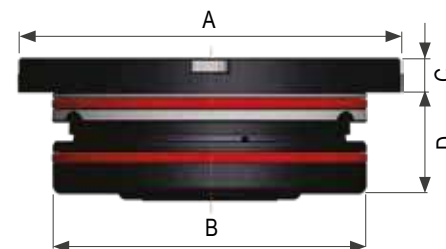
Tipo (grandezza) Zero-Point Zero-Point type (size)		3 up to 40 kN
Pressione apertura / Opening pressure	BAR	7 ÷ 14
Art. 665S ZERO-POINT pneumatico SINGOLO montaggio incassato SINGLE pneumatic ZERO-POINT built-in mounting	A	∅168
	B	∅138 h7
	C	15
	D	47
Forma Shape		
kg		5,8
Cod.		9.66.5S300

 Chiavette comprese nel prezzo
 keyways included in the price

Dotazione standard - Standard equipment:

- 1 tirante Art.11A
- 1 tappo teflon con O-Ring Art.9
- 1 Pull-stud Art.11A
- Teflon cap with O-Ring Art.9

AMPLIA LE TUE APPLICAZIONI TRAMITE GLI ACCESSORI MODULARI !

Art. 408 Moltiplicatore di pressione aria Pressure air multiplier Vedi Pag - See Page 9.19		Cod. 9.40.80000
--	--	-----------------

Art. 399 Gruppo filtro riduttore più lubrificatore Compressed air preparation unit Vedi Pag - See Page 9.39		Cod. 4.39.90000
---	--	-----------------

Art. 10A
TIPO 1 / TYPE 1

 Perno tirante di **centraggio**. Filetto femmina
 Centering pull-stud. Female thread

 Pag - Page
 9.34

Cod. 9.10.A1000

Art. 11A
TIPO 1 / TYPE 1

 Perno tirante di **centraggio**. Filetto maschio
 Centering pull-stud. Male thread

 Pag - Page
 9.34

Cod. 9.11.A1000

Art. 10S
TIPO 2 / TYPE 2

 Perno tirante di **centraggio** per Zero Point **singolo**. Filetto femmina
 Centering pull-stud for **single** Zero Point. Female thread

 Pag - Page
 9.35

Cod. 9.10.S2000

Art. 11S
TIPO 2 / TYPE 2

 Perno tirante di **centraggio** per Zero Point **singolo**. Filetto maschio
 Centering pull-stud for **single** Zero Point. Male thread

 Pag - Page
 9.35

Cod. 9.11.S2000

Art. 10A
NEW!
TIPO 3 / TYPE 3

 Perno tirante di **centraggio** per Zero Point **singolo**. Filetto femmina
 Centering pull-stud for **single** Zero Point. Female thread

 Pag - Page
 9.36

Cod. 9.10.A3000

Art. 11A
NEW!
TIPO 3 / TYPE 3

 Perno tirante di **centraggio** per Zero Point **singolo**. Filetto maschio
 Centering pull-stud for **single** Zero Point. Male thread

 Pag - Page
 9.36

Cod. 9.11.A3000

UPGRADE YOUR VISE APPLICATIONS THROUGH MODULAR ACCESSORIES !

Art. 402/90

 Distributore leva angolare 90, 3 vie
 90° angular valve, 3 ways

Vedi Pag - See Page 9.39



Cod. 9.40.29000

Art. PN11

 Blocchetto di connessione
 con innesto rapido - 1/8" Gas
 Connection block
 with quick male coupling - 1/8" Gas

Vedi Pag - See Page 9.3



Cod. 9.PN.11000

PARTI DI RICAMBIO ZERO POINT SINGOLO Art. 665S
 SINGLE ZERO POINT SPARE PARTS Art. 665S









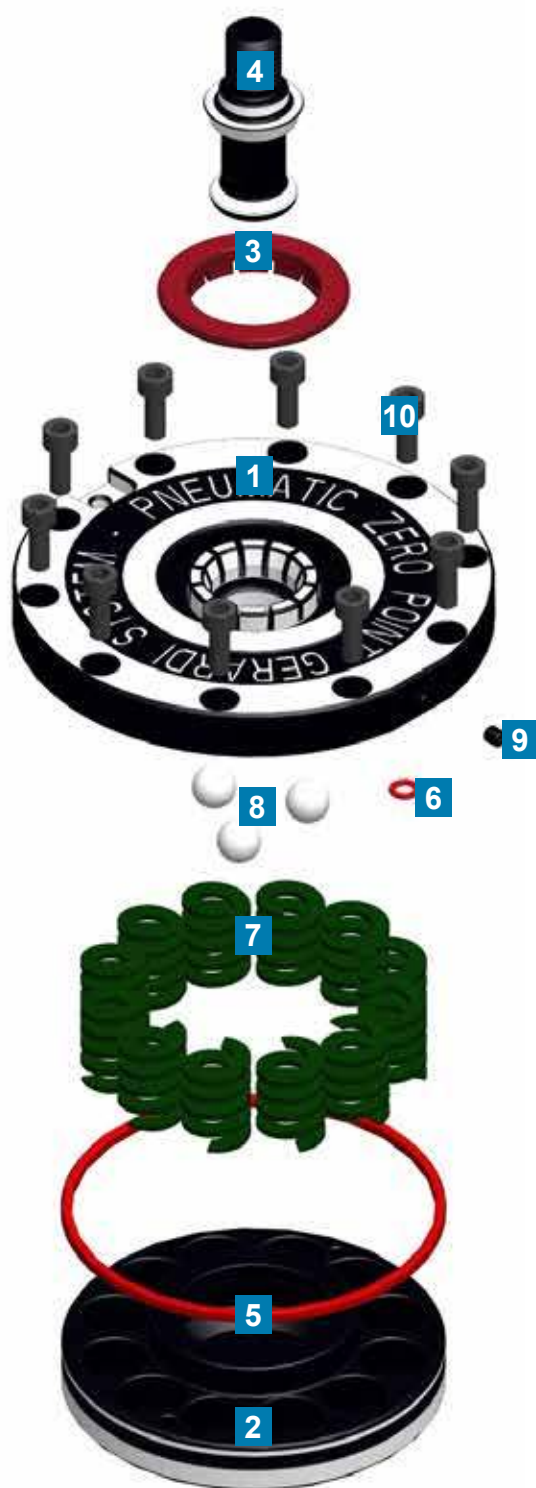

	1	CORPO Z.P PNEUMATICO PNEUMATIC Z.P BODY
	2	PISTONE PNEUMATICO PNEUMATIC PISTON
	3	TIRANTE PULL-STUD
	4	GUARNIZIONE O-RING
	5	GUARNIZIONE O-RING
	6	GUARNIZIONE O-RING
	7	SFERE DI BLOCCAGGIO CLAMPING SPHERE
	8	MOLLE PER STAMPI DIE SPRING
	9	VITI TESTA CILINDRICA SOCKETED HEAD SCREWS

ZERO POINT KIT VERSIONE "S"
 ZERO POINT KIT "S" VERSION

Art. 665SK **NEW!**

	Type 1	Type 2	Type 3
Cod.	9.66.5SK10	9.66.5SK20	9.66.5SK30

PARTI DI RICAMBIO ZERO POINT MULTIPLO Art. 665
MULTIPLE ZERO POINT SPARE PARTS Art. 665

	1	CORPO Z.P PNEUMATICO PNEUMATIC Z.P BODY
	2	PISTONE PNEUMATICO PNEUMATIC PISTON
	3	TENUTA PULIZIA PINZA CLEAN COLLET SEAL
	4	GUARNIZIONE O-RING
	5	GUARNIZIONE O-RING
	6	GUARNIZIONE O-RING
	7	MOLLE PER STAMPI DIE SPRING
	8	SFERE DI BLOCCAGGIO CLAMPING SPHERE
	9	GRANO SOCKET SET SCREW
	10	VITI TESTA CILINDRICA SOCKETED HEAD SCREWS

KIT ZERO POINT
ZERO POINT KIT

Art. 665K
NEW!

	Type 1	Type 2	Type 3
Cod.	9.66.5K100	9.66.5K200	9.66.5K300

ABBATTIMENTO TEMPI DI ALLESTIMENTO MACCHINA PRODUCTION OPTIMIZATION

La tabella illustra il costo del piazzamento di una macchina.

Il sistema Zero Point vi permette di rimuovere in pochi secondi i lavori sulla macchina e preparare un nuovo lavoro/morsa quando il lavoro precedente è ultimato, **risparmiando quasi il 95% sui tempi di allestimento.**

Ipoteticamente dovendo impiegare 2 ore al giorno a € 40,00 all'ora per attrezzare ogni macchina, attrezzare 5 macchine a CNC vi costa all'incirca € 100.000 in profitti persi ogni anno.

Il sistema Zero Point vi permette di salvare centinaia di ore di "tempi morti" e **avere più profitti.**

The table illustrates how much it costs on just 1 machine to set up jobs on the machine.

Zero Point allows you to set up jobs off the machine and position the new job/vise in few seconds on the machine when the last job finishes, **saving around 95% set up time.**

5 CNC machines being set 2 hours a day @ € 40,00 an hour is costing you at least € 100.000 in lost profits every year.

Zero Point will allow you to save hundreds of hours in down time and **make thousands more in profits.**

Costo orario della macchina Machine cost per hour	Tempo giornaliero utilizzato per l'attrezzaggio Time per day machine spent being set up	Costo annuale dei "tempi morti" Cost per year of down time*	Potenziale profitto extra con gli Zero Point Zero Point potential extra profit
€ 25,00	2 ORE 2 HOURS	- € 12.500 persi lost	- € 11.875 risparmio savings
€ 40,00	2 ORE 2 HOURS	- € 20.000 persi lost	- € 19.000 risparmio savings
€ 60,00	2 ORE 2 HOURS	- € 30.000 persi lost	- € 28.500 risparmio savings
€ 75,00	2 ORE 2 HOURS	- € 37.500 persi lost	- € 35.625 risparmio savings

* Basato su 5 giorni lavorativi, 50 settimane per anno

* Based on a 5 day working week, 50 weeks per year



Spalla porta-pezzo in fusione monoblocco con n°18 unità ZERO POINT Art.665 tipo 2 con morsa FMS autocentrante Art.863 tipo 5x800
 Tombstones in solid cast iron with n°18 Zero point units Art.665 type 2 with FMS vise chuck Art.863 type 5x800

OPZIONI DI INCREMENTO FORZA DI SERRAGGIO ZERO-POINT MULTIPLO

INCREASE CLAMPING POWER OPTIONS FOR MULTIPLE ZERO-POINT

Sistema di moltiplicazione di pressione aria con rapporto 1:2.

Mediante questo sistema vi è la possibilità di variare il numero e/o la tipologia di molle all' interno dello zero-point per avere una maggiore forza di serraggio *
 Set for air overpressure with ratio 1:2.

This set allows the springs variation in type and/or quantity on the zero-point, to obtain a superior clamping strength *

AIR OUTPUT X2

Art. 408



Cod. 9.40.80000

FORZA DI SERRAGGIO - CLAMPING POWER

Pressione apertura bar Opening pressure bar		Tipo 1 Type 1	Type 2 Type 2	Type 3 Type 3
Entrata Input	Uscita Output			
3	6	4,7 kN	9 kN	15 kN
3,5	7	5,4 kN	10 kN	16 kN
4	8	6,2 kN	11 kN	18 kN
5	10	7,7 kN	14 kN	24 kN
6	12	9,3 kN	15 kN	26 kN
7	14	11 kN	18 kN	30 kN

* Richiedere in fase d'ordine - Ask when placing the purchase order

OPZIONI DI INCREMENTO FORZA DI SERRAGGIO ZERO-POINT SINGOLO

SINGLE ZERO-POINT OPTIONS FOR CLAMPING POWER INCREASE

La funzione DOPPIO EFFETTO (sempre inclusa) permette di ottenere parametri di serraggio notevolmente superiori rispetto al normale funzionamento. Quando è azionata l' aria compressa aggiunge una forza pneumatica in supporto al normale sistema di serraggio tramite molle.

NEW!

The DOUBLE EFFECT always included, thanks to the fast mounting with non-return valve, allows to get clamping results much higher than the normal. When the double effect is operated the air adds a pneumatic clamping power which supports and increases the normal clamping through springs.

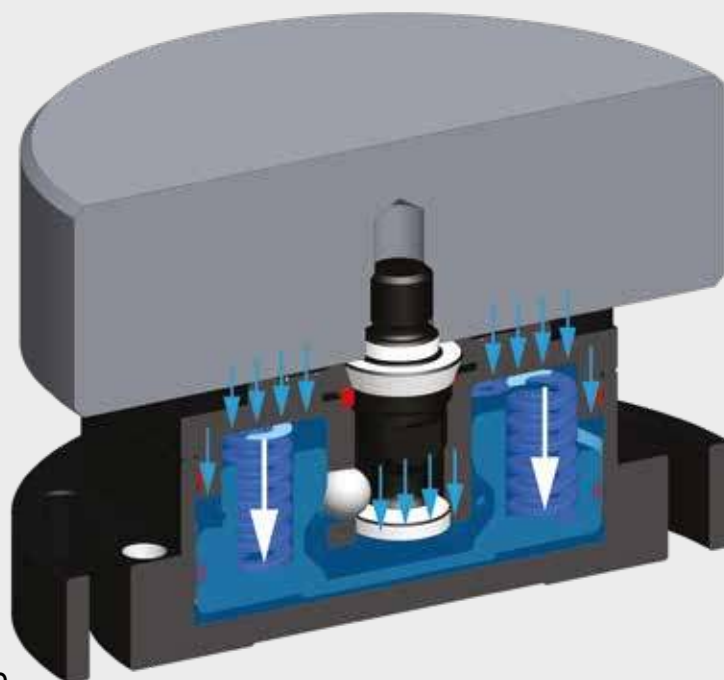
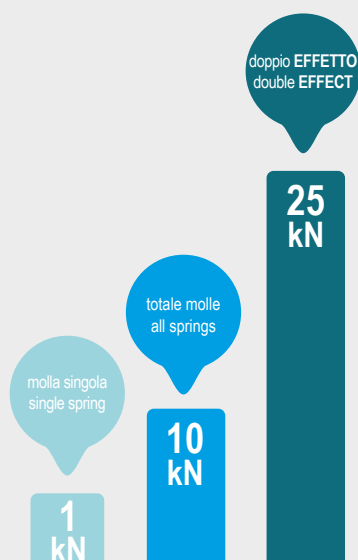

Comparazione kN tra serraggio standard e sistema DOPPIO EFFETTO.
 kN comparison between standard clamping and DOUBLE EFFECT.

PIASTRE INTERFACCIAE* CON ZERO POINT

ZERO POINT INTERFACED* HEAD PLATES

 Opzione apertura indipendente Zero Point
 Zero point independent control option

SOVRAPREZZO - EXTRA PRICE:

PIASTRE QUADRATE , MONTAGGIO CON FLANGIA - SQUARE PLATES , FLANGE MOUNTING

Art. 70P

 Per centri **ORIZZONTALI**
 For **HORIZONTAL** machining centres

Art.664: € 820

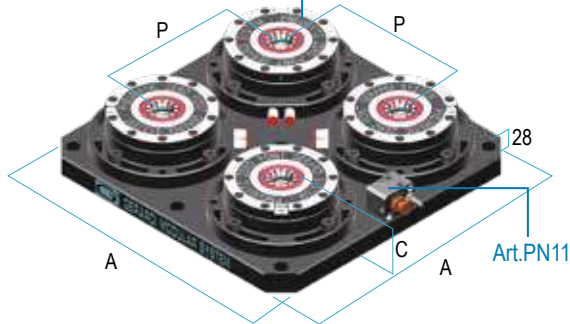

	A	B	C	P	kg	Cod
Acciaio Steel	400	400	79	200	59	9.70.P4040S4
Alluminio Aluminum					34	9.70.P4040A4
Acciaio Steel	500	500	79	200 - 250 - 300	78	9.70.P5050S4
Alluminio Aluminum					35	9.70.P5050A4
Acciaio Steel	630	630	79	200 - 250 - 300	110	9.70.P6363S4
Alluminio Aluminum					46	9.70.P6363A4
Acciaio Steel	800	800	79	200 - 300 - 400	163	9.70.P8080S4
Alluminio Aluminum					65	9.70.P8080A4

PIASTRE RETTANGOLARI , MONTAGGIO CON FLANGIA - RECTANGULAR PLATES , FLANGE MOUNTING

Art. 71P

 Per centri **VERTICALI**
 For **VERTICAL** machining centres

Art.664:

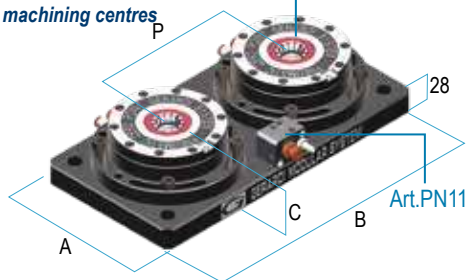

	A	B	C	P	P1	kg	Cod
Acciaio Steel	200	400	79	200	-	29	9.71.P2040S2
Alluminio Aluminum					13	9.71.P2040A2	
Acciaio Steel	200	500	79	200 250 300	-	33	9.71.P2050S2
Alluminio Aluminum					14	9.71.P2050A2	
Acciaio Steel	200	600	79	400	-	38	9.71.P2060S2
Alluminio Aluminum					17	9.71.P2060A2	

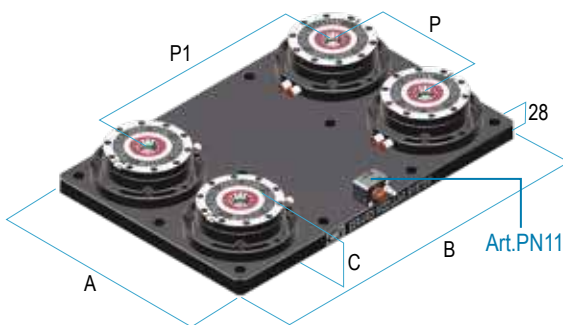
 Per centri **VERTICALI**
 For **VERTICAL** machining centres

Acciaio Steel	400	500	79	200	300	67	9.71.P4050S4
Alluminio Aluminum						31	9.71.P4050A4
Acciaio Steel	400	600	79	200	400	76	9.71.P4060S4
Alluminio Aluminum						34	9.71.P4060A4
Acciaio Steel	400	700	79	200	500	85	9.71.P4070S4
Alluminio Aluminum						37	9.71.P4070A4
Acciaio Steel	400	800	79	200	600	94	9.71.P4080S4
Alluminio Aluminum						92	9.71.P4080A4

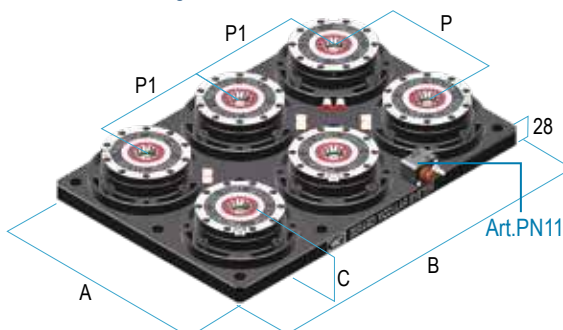
 Per centri **VERTICALI**
 For **VERTICAL** machining centres

Acciaio Steel	400	500	79	200	200	79	9.71.P4050S6
Alluminio Aluminum						38	9.71.P4050A6
Acciaio Steel	400	600	79	200	200	88	9.71.P4060S6
Alluminio Aluminum						41	9.71.P4060A6
Acciaio Steel	400	700	79	200	250	97	9.71.P4070S6
Alluminio Aluminum						83	9.71.P4070A6
Acciaio Steel	400	800	79	200	300	106	9.71.P4080S6
Alluminio Aluminum						47	9.71.P4080A6

! Alluminio - Anticorodal - ossidazione dura - Alloy 6082 - Anticorodal - Hard anodizing
 (x) = n° Zero Point come da figura - (x) = n° Zero Point pieces shown in the image

* La personalizzazione comprende 4/8 fori per ancoraggio e 2 riferimenti per posizionamento (chiavette o fori calibrati) vedi pag. 8.4

* The interface includes 4/8 holes for clamping and 2 reference points for positioning (key-ways or ground screws) see pag. 8.4

CARTER IN ACCIAIO INOX PER PIASTRE INTERFACCIAE CON ZERO POINT

STAINLESS STEEL COVER FOR ZERO POINT INTERFACED HEAD PLATES

CARTER PER PIASTRE QUADRATE - SQUARE PLATES COVER

Art. 70CP

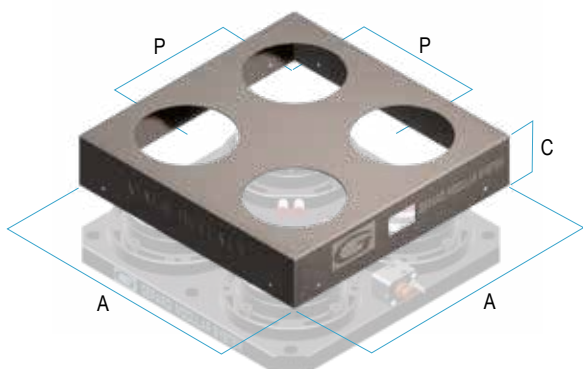

Cod. riferimento Piastra Reference plate code	kg	Cod. Carter Cover code	
9.70.P4040S4	2,7	9.70.CP40404	
9.70.P5050S4	4,1	9.70.CP50504	
9.70.P6363S4	6,4	9.70.CP63634	
9.70.P8080S4	9,8	9.70.CP80804	

CARTER PER PIASTRE RETTANGOLARI - RECTANGULAR PLATES COVER

Art. 71CP

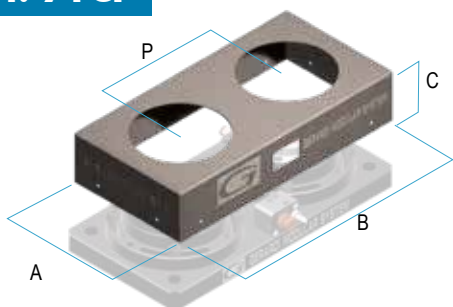

Cod. riferimento Piastra Reference plate code	kg	Cod. Carter Cover code	
9.71.P2040S2	1,7	9.71.CP20402	
9.71.P2050S2	2,1	9.71.CP20502	
9.71.P2060S2	2,5	9.71.CP20602	

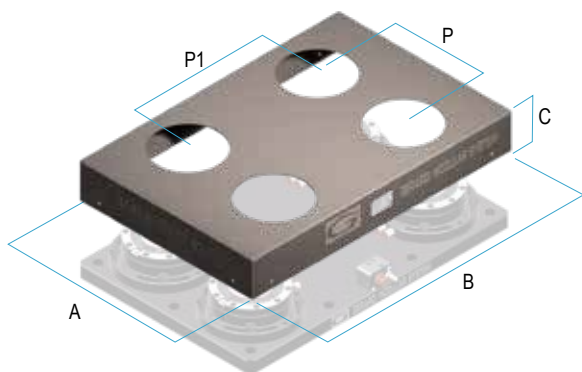

9.71.P4050S4	3,3	9.71.CP40504	
9.71.P4060S4	4	9.71.CP40604	
9.71.P4070S4	4,6	9.71.CP40704	
9.71.P4080S4	5,3	9.71.CP40804	

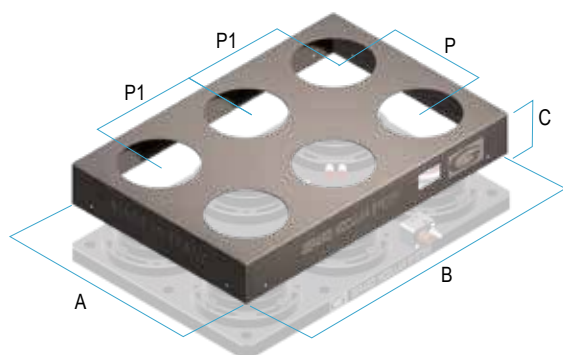

9.71.P4050S6	3	9.71.CP40506	
9.71.P4060S6	3,6	9.71.CP40606	
9.71.P4070S6	4,3	9.71.CP40706	
9.71.P4080S6	4,9	9.71.CP40806	

PIASTRE INTERFACCIAE* CON ZERO POINT

ZERO POINT INTERFACED* HEAD PLATES

 Opzione apertura indipendente Zero Point
 Zero point independent control option

SOVRAPREZZO - EXTRA PRICE:
PIASTRA QUADRATA , MONTAGGIO INCASSATO - SQUARE PLATES , BUILT-IN MOUNTING
Art. 80P

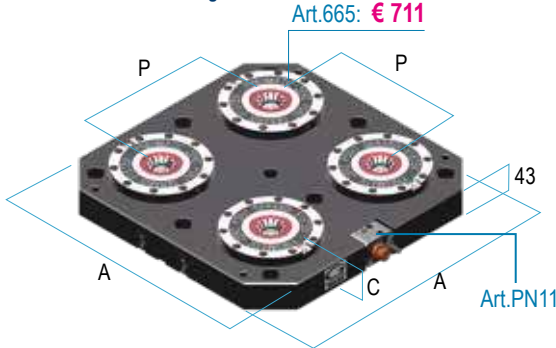
 Per centri **ORIZZONTALI**
 For **HORIZONTAL** machining centres

	A	B	C	P	kg	Cod
Acciaio Steel	400	400	58	200	60	9.80.P4040S4
Alluminio Aluminum					29	9.80.P4040A4
Acciaio Steel	500	500	58	250	91	9.80.P5050S4
Alluminio Aluminum					44	9.80.P5050A4
Acciaio Steel	630	630	58	250 - 300	140	9.80.P6363S4
Alluminio Aluminum					58	9.80.P6363A4
Acciaio Steel	800	800	58	200 - 300 - 400	220	9.80.P8080S4
Alluminio Aluminum					87	9.80.P8080A4

PIASTRE RETTANGOLARI, MONTAGGIO INCASSATO - RECTANGULAR PLATES , BUILT-IN MOUNTING
Art. 81P

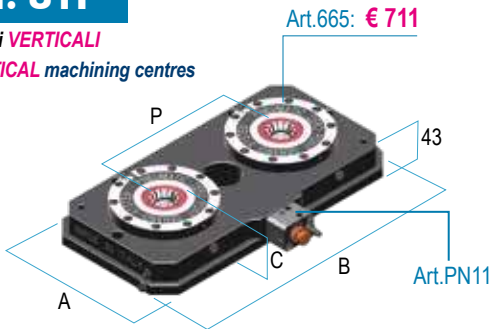
 Per centri **VERTICALI**
 For **VERTICAL** machining centres

	A	B	C	P	P1	kg	Cod
Acciaio Steel	200	400	58	200	-	29	9.81.P2040S2
Alluminio Aluminum						15	9.81.P2040A2
Acciaio Steel	200	500	58	250	-	35	9.81.P2050S2
Alluminio Aluminum						17	9.81.P2050A2
Acciaio Steel	200	600	58	300	-	42	9.81.P2060S2
Alluminio Aluminum						25	9.81.P2060A2

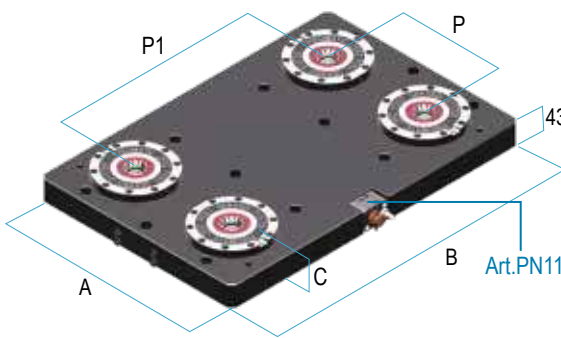
 Per centri **VERTICALI**
 For **VERTICAL** machining centres

Acciaio Steel	400	500	58	200	300	74	9.81.P4050S4
Alluminio Aluminum						34	9.81.P4050A4
Acciaio Steel	400	600	58	200	400	87	9.81.P4060S4
Alluminio Aluminum						39	9.81.P4060A4
Acciaio Steel	400	700	58	200	500	100	9.81.P4070S4
Alluminio Aluminum						44	9.81.P4070A4
Acciaio Steel	400	800	58	200	600	114	9.81.P4080S4
Alluminio Aluminum						49	9.81.P4080A4

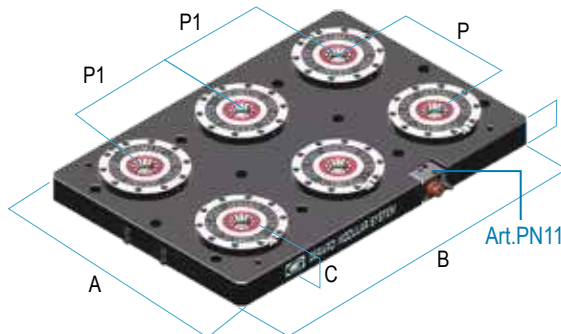
 Per centri **VERTICALI**
 For **VERTICAL** machining centres

Acciaio Steel	400	500	58	200	150	79	9.81.P4050S6
Alluminio Aluminum						39	9.81.P4050A6
Acciaio Steel	400	600	58	200	200	91	9.81.P4060S6
Alluminio Aluminum						44	9.81.P4060A6
Acciaio Steel	400	700	58	200	250	105	9.81.P4070S6
Alluminio Aluminum						49	9.81.P4070A6
Acciaio Steel	400	800	58	200	300	118	9.81.P4080S6
Alluminio Aluminum						54	9.81.P4080A6

 ! Alluminio - Anticorodal - ossidazione dura - Alloy 6082 - Anticorodal - Hard anodizing
 (x) = n° Zero Point come da figura - (x) = n° Zero Point pieces shown in the image

* La personalizzazione comprende 4/8 fori per ancoraggio e 2 riferimenti per posizionamento (chiavette o fori calibrati) vedi pag. 8.4

* The interface includes 4/8 holes for clamping and 2 reference points for positioning (key-ways or ground screws) see pag. 8.4

PIASTRE TONDE INTERFACCIAE CON ZERO POINT

ZERO POINT INTERFACED ROUNDED HEAD PLATES

 Opzione apertura indipendente Zero Point
 Zero point independent control option

SOVRAPREZZO - EXTRA PRICE:
MONTAGGIO CON FLANGIA o INCASSATO - BUILT-IN or FLANGE MOUNTING

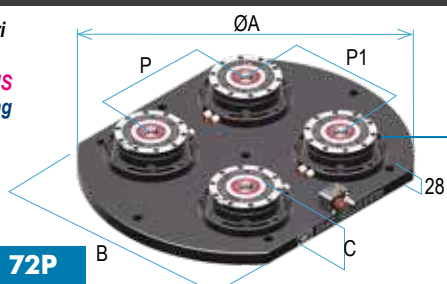
 Per centri
 a 5 ASSI
 For 5 AXIS
 machining
 centres

Art.664:

Art. 72P

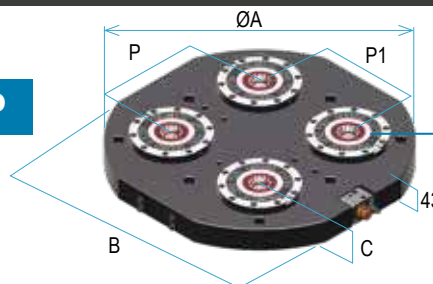
 Piastra tonda con
 Zero Point **Art.664**
 montaggio con flangia
 Rounded plates with
 Zero Point **Art.664**
 mounting with flange

Art.665:

Art. 82P

 Piastra tonda con
 Zero Point **Art.665**
 montaggio incassato
 Rounded plates with
 Zero Point **Art.665**
 built-in mounting

Art. 72P

Dimensioni Dimension	Hermule C600U	DMG DMU 50 Evo	Mazak Variax 500	Hermule C40U	DMG DMU 50	Haas UMC 750	Mazak Variax 630	DMG DMU 70 Evo	DMG DMC 635V	DMG DMC 1035V	DMG DMU 80P	
ØA	280	500	500	420	630	630	630	700	790	1000	900	
B	-	380	400	-	500	500	500	500	560	560	630	
C	79	79	79	79	79	79	79	79	79	79	79	
P	-	200	200	200	200 / 250 / 300	200 / 250 / 300	200 / 250 / 300	200 / 300 / 400	200 / 250	200 / 300 / 350	200 / 250	
P1	-	200	200	200	200 / 250 / 300	200 / 250 / 300	200 / 250 / 300	200 / 300	200 / 250 / 300	200 / 300 / 400	200 / 300 / 400	
N° Zero Point	1	4	4	4	4	4	4	4	6	8	6	
kg	19	11	61	37	63	38	65	35	85	46	85	46
Cod.	9.72.P2828S1	9.72.P2828A1	9.72.P5038S4	9.72.P5038A4	9.72.P5040S4	9.72.P5040A4	9.72.P4242S4	9.72.P4242A4	9.72.P6350S4	9.72.P6350A4	9.72.P6350S4	9.72.P6350A4
	390	Aluminio Aluminum	Acciaio Steel	Aluminio Aluminum	Acciaio Steel	Aluminio Aluminum	Acciaio Steel	Aluminio Aluminum	Acciaio Steel	Aluminio Aluminum	Acciaio Steel	Aluminio Aluminum

Art. 82P

Dimensioni Dimension	Hermule C600U	DMG DMU 50 Evo	Mazak Variax 500	Hermule C40U	DMG DMU 50	Haas UMC 750	Mazak Variax 630	DMG DMU 70 Evo	DMG DMC 635V	DMG DMC 1035V	DMG DMU 80P	
ØA	280	500	500	420	630	630	630	700	790	1000	900	
B	-	380	400	-	500	500	500	500	560	560	630	
C	58	58	58	58	58	58	58	58	58	58	58	
P	150	200 / 250	200 / 250	200	200 / 250 / 300	200 / 250 / 300	200 / 250 / 300	200 / 300 / 400	200 / 250	200 / 250 / 350	200 / 250 / 300	
P1	-	200	200 / 250	200	200 / 250 / 300	200 / 250 / 300	200 / 250 / 300	200 / 250 / 300	200 / 300 / 400	200 / 300 / 400	200 / 300 / 400	
N° Zero Point	2	4	4	4	4	4	4	4	6	8	6	
kg	30	17	67	29	69	31	56	26	103	43	103	43
Cod.	9.82.P2828S2	9.82.P2828A2	9.82.P5038S4	9.82.P5038A4	9.82.P5040S4	9.82.P5040A4	9.82.P4242S4	9.82.P4242A4	9.82.P6350S4	9.82.P6350A4	9.82.P6350S4	9.82.P6350A4
	390	Aluminio Aluminum	Acciaio Steel	Aluminio Aluminum	Acciaio Steel	Aluminio Aluminum	Acciaio Steel	Aluminio Aluminum	Acciaio Steel	Aluminio Aluminum	Acciaio Steel	Aluminio Aluminum

CARTER PER PIASTRE TONDE - ROUNDED PLATES COVER

Art. 72CP

 Carter per piastre tonde
 con zero point pneumatici
 Cover for pneumatic Zero Point
 interfaced rounded plates

**ESEMPIO DI MONTAGGIO
 MOUNTING EXAMPLE**
Art. 72CP

kg	1.4	2.7	2.8	2.2	4.4	4.4	5	5.9	7.5	7.6
Cod.	9.72.CP28281	9.72.CP50384	9.72.CP50404	9.72.CP42424	9.72.CP63504	9.72.CP63504	9.72.CP70504	9.72.CP79566	9.72.CP10568	9.72.CP90636

* Zero Point non inclusi - Zero Point not included

PIASTRE DI INTERFACCIA INTERFACE PLATES						ACCIAIO STEEL METAL Fe420		ALLUMINIO ALUMINUM AL5083	
	A	B	C	P	P1	Kg	Cod.	Kg	Cod.

Dimensione mm
Dimensions mm

Art. 61i

Piastra base liscia con tiranti femmina Art.10A - 10B per cambio rapido ZERO POINT

Smooth base plate with female pull-studs Art.10A - 10B for ZERO POINT quick change

In fase d'ordine specificare la quota **P**
Order must include **P** dimensions

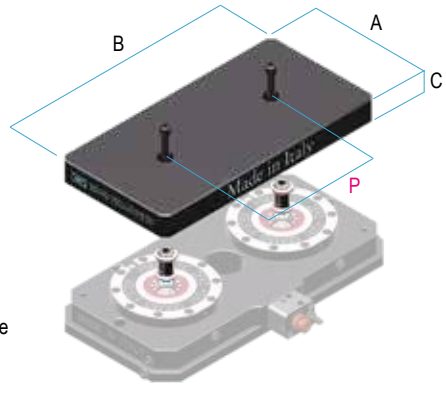

200	400	38	200	-	24	9.61.I2040S2		9	9.61.I2040A2
200	500	38	250	-	30	9.61.I2050S2		11	9.61.I2050A2
200	600	38	300	-	36	9.61.I2060S2		13	9.61.I2060A2

2 sedi per tiranti Zero Point / 2 Zero Point Pull-stud seats

! Per lavorazioni o materiali diversi (ghisa), richiedere quotazione specifica
For different finishing and materials (cast iron), ask for specific quotation

Art. 61i

Piastra base liscia con tiranti femmina Art.10A - 10B per cambio rapido ZERO POINT

Smooth base plate with female pull-studs Art.10A - 10B for ZERO POINT quick change

In fase d'ordine specificare la quota **P** e **P1**
Order must include **P** and **P1** dimensions

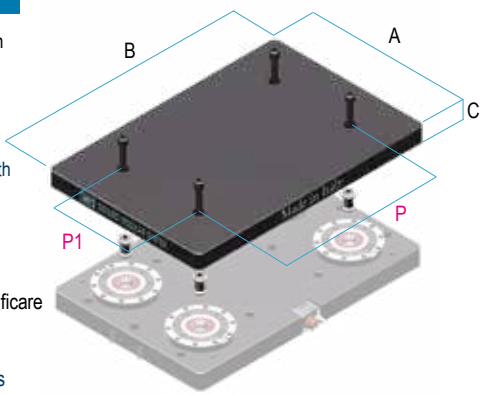

A	B	C	P	P1	ACCIAIO STEEL METAL Fe420		ALLUMINIO ALUMINUM AL5083	
					Kg	Cod.	Kg	Cod.
400	500	38	200	300	59	9.61.I4050S4	21	9.61.I4050A4
400	600	38	200	400	71	9.61.I4060S4	26	9.61.I4060A4
400	700	38	200	500	83	9.61.I4070S4	30	9.61.I4070A4
400	800	38	200	600	95	9.61.I4080S4	34	9.61.I4080A4

4 sedi per tiranti Zero Point / 4 Zero Point Pull-stud seats

! Per lavorazioni o materiali diversi (ghisa), richiedere quotazione specifica
For different finishing and materials (cast iron), ask for specific quotation

Art. 61i

Piastra base liscia con tiranti femmina Art.10A - 10B per cambio rapido ZERO POINT

Smooth base plate with female pull-studs Art.10A - 10B for ZERO POINT quick change

In fase d'ordine specificare la quota **P** e **P1**
Order must include **P** and **P1** dimensions

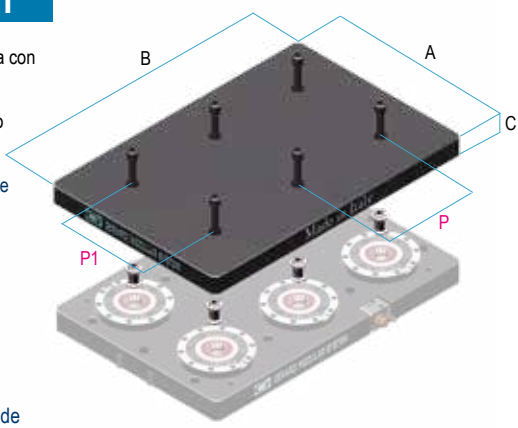

A	B	C	P	P1	ACCIAIO STEEL METAL Fe420		ALLUMINIO ALUMINUM AL5083	
					Kg	Cod.	Kg	Cod.
400	500	38	200	150	59	9.61.I4050S6	21	9.61.I4050A6
400	600	38	200	200	71	9.61.I4060S6	26	9.61.I4060A6
400	700	38	200	250	83	9.61.I4070S6	30	9.61.I4070A6
400	800	38	200	300	95	9.61.I4080S6	34	9.61.I4080A6

6 sedi per tiranti Zero Point / 6 Zero Point Pull-stud seats

! Per lavorazioni o materiali diversi (ghisa), richiedere quotazione specifica
For different finishing and materials (cast iron), ask for specific quotation

* In alternativa: applicazione di tiranti maschio Art.11A - Art.11B per cambio rapido ZERO POINT compresi - As alternative: male pull studs Art.11A - Art.11B for ZERO POINT quick change included

PIASTRE DI INTERFACCIA INTERFACE PLATES				ACCIAIO STEEL METAL Fe420			ALLUMINIO ALUMINUM AL5083		
--	--	--	--	---------------------------------	--	--	---------------------------------	--	--

Dimensione mm
Dimensions mm

Art. 60i

Piastra base liscia con tiranti femmina Art.10A - 10B per cambio rapido ZERO POINT

Smooth base plate with female pull-studs Art.10A - 10B for ZERO POINT quick change

In fase d'ordine specificare la quota P
Order must include P dimensions

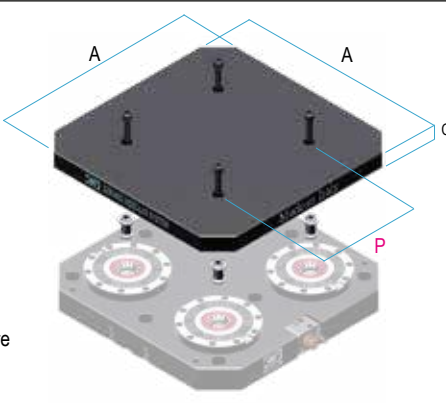

4 sedi per tiranti Zero Point / 4 Zero Point Pull-stud seats

A	C	P	Kg	Cod.		Kg	Cod.	
400	38	200	47	9.60.14040S4		16	9.60.14040A4	
500	38	250	70	9.60.15050S4		25	9.60.15050A4	
630	38	300	115	9.60.16363S4		41	9.60.16363A4	
800	38	300 400	180	9.60.18080S4		65	9.60.18080A4	

! Per lavorazioni o materiali diversi (ghisa), richiedere quotazione specifica
For different finishing and materials (cast iron), ask for specific quotation

Art. 62i

Piastra base rotonda liscia con tiranti femmina Art.10A - 10B per cambio rapido ZERO POINT

Smooth rounded base plate with female pull-studs Art.10A - 10B for ZERO POINT quick change

In fase d'ordine specificare la quota P
Order must include P dimensions

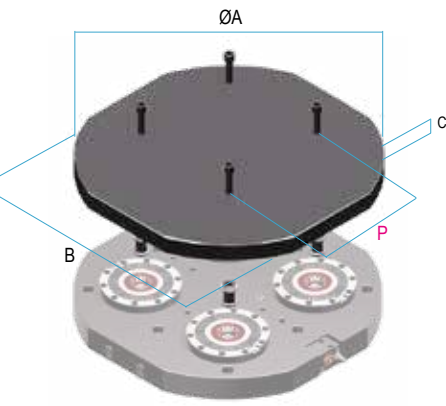

4 sedi per tiranti Zero Point / 4 Zero Point Pull-stud seats

ØA	B	C	P	ACCIAIO STEEL METAL Fe420			ALLUMINIO ALUMINUM AL5083		
				Kg	Cod.		Kg	Cod.	
400	320	38	200	37	9.62.14032S4		13	9.62.14032A4	
500	400	38	250	58	9.62.15040S4		21	9.62.15040A4	
630	500	38	300	93	9.62.16350S4		33	9.62.16350A4	
800	630	38	300	-	9.62.18063S4		-	9.62.18063A4	

! Per lavorazioni o materiali diversi (ghisa), richiedere quotazione specifica
For different finishing and materials (cast iron), ask for specific quotation

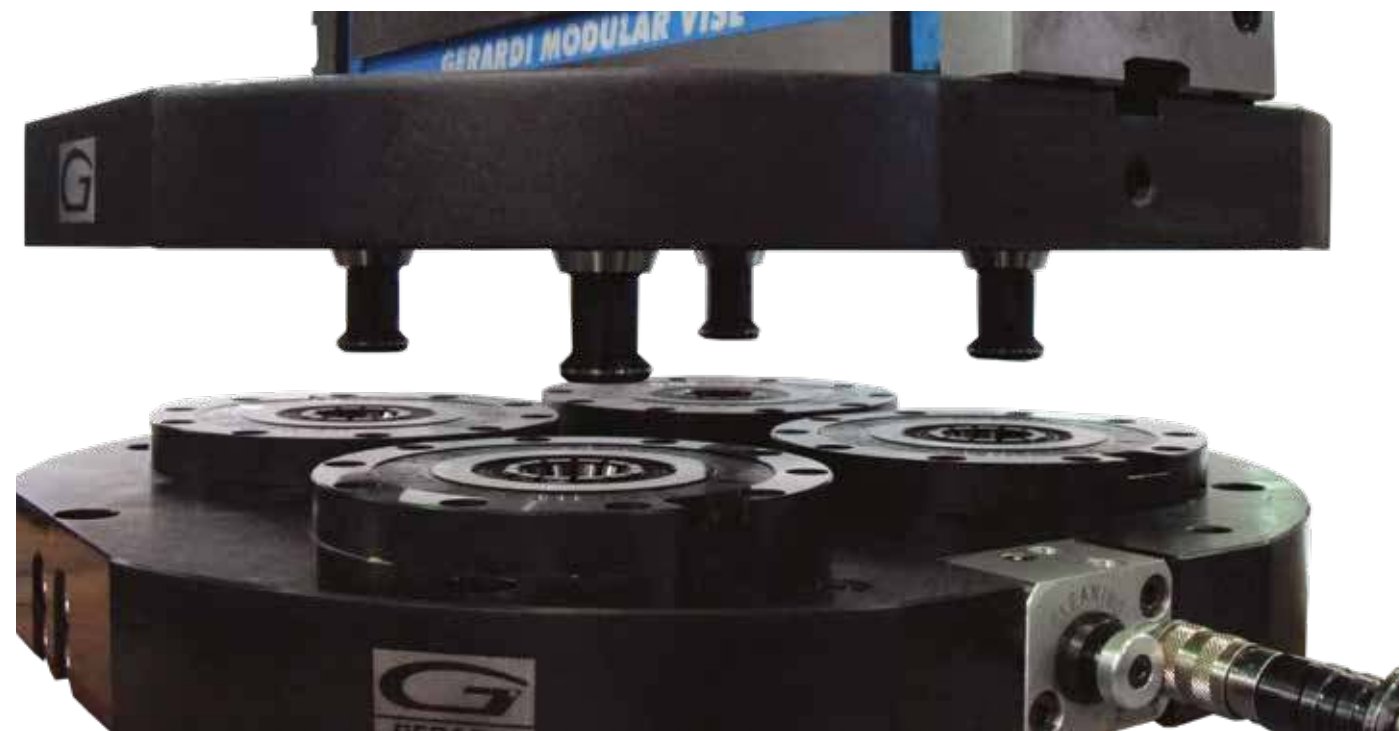

RIALZI PER ZERO POINT

RISERS FOR ZERO POINT

NEW!

Tipo (grandezza) / Type (size)	1	2
Art. 63 <i>Tipo / Type 1 e 2</i>		
ØA	138	188
ØC	90	120
E	100	135
ØF	120	165
G	26	28
H	100	125
H1	88	110
	Acciaio - Steel	Acciaio - Steel
kg	3	8
Cod.	9.63.10000	9.63.20000

 Rialzo singolo con Zero Point Art.665S
 Riser with Zero Point Art.665S

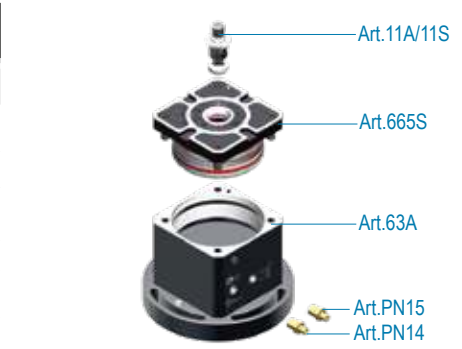
NEW!

Dotazione standard - Standard equipment:

- 1 tirante Art.11A / 11S ■ 1 tappo teflon con O-Ring Art.9
- 1 perno di centraggio Art.640P (*Indicare dimensione in fase d'ordine*)
- 1 spina calibrata Art.83
- 1 Pull-stud Art.11A / 11S ■ Teflon cap with O-Ring Art.9
- 1 positioning pin Art.640P (*Dimension to be advised at order*)
- 1 shoulder calibrated screw Art.83

Tipo (grandezza) / Type (size)	3
Art. 63 <i>Tipo / Type 3</i>	
ØA	213
ØC	168
ØF	190
G	26
H	150
H1	135
	Acciaio - Steel
kg	24
Cod.	9.63.30000

 Rialzo singolo con Zero Point Art.665S
 Single riser with Zero Point Art. 665S

NEW!

Dotazione standard - Standard equipment:

- 1 tirante Art.11A ■ 1 tappo teflon con O-Ring Art.9
- 1 perno di centraggio Art.640P (*Indicare dimensione in fase d'ordine*)
- 1 spina di orientamento Art. 79
- 1 Pull-stud Art.11A ■ Teflon cap with O-Ring Art.9
- 1 positioning pin Art.640P (*Dimension to be advised at order*)
- 1 shoulder calibrated pin Art. 79

Tipo (grandezza) / Type (size)	1	2
Art. 64 <i>Tipo / Type 1 e 2</i>		
A	270	340
B	120	175
C	90	120
D	100	150
E	250	300
F	-	250
G	20	26
H	100	150
H1	88	135
P	150	200
P1	150	200
	Alluminio - Aluminum	Alluminio - Aluminum
kg	7,3	19
Cod.	9.64.10000	9.64.20000

 Rialzo doppio con Zero Point Art.665S
 Double riser with Zero Point Art.665S

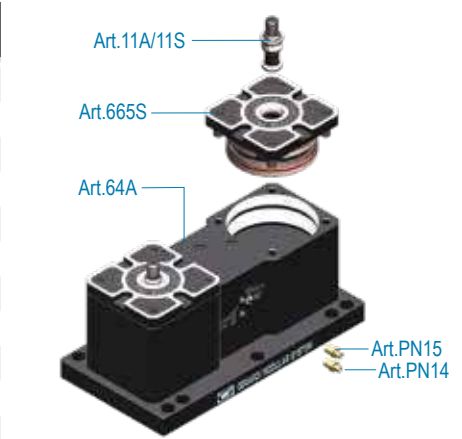
NEW!

Dotazione standard - Standard equipment:

- 1 tirante Art.11A / 11S ■ 1 tappo teflon con O-Ring Art.9
- 2 perni di centraggio Art.640P (*Indicare dimensione in fase d'ordine*)
- 1 spina di orientamento Art.79
- 1 Pull-stud Art.11A / 11S ■ Teflon cap with O-Ring Art.9
- 2 positioning pins Art.640P (*Dimension to be advised at order*)
- 1 shoulder calibrated pin Art.79

9

RIALZI PER ZERO POINT RISERS FOR ZERO POINT

NEW!

Art. 63 *Tipo / Type 1 e 2*

Rialzo singolo con Zero Point Art.665S
Single riser with Zero Point Art.665S

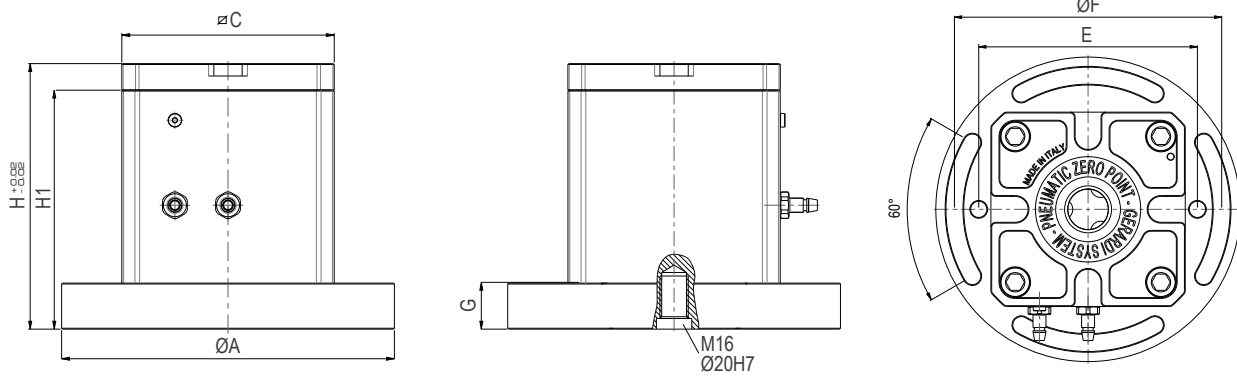

Art. 63 *Tipo / Type 3*

Rialzo singolo Zero Point Art.665S
Single riser with Zero Point Art.665S

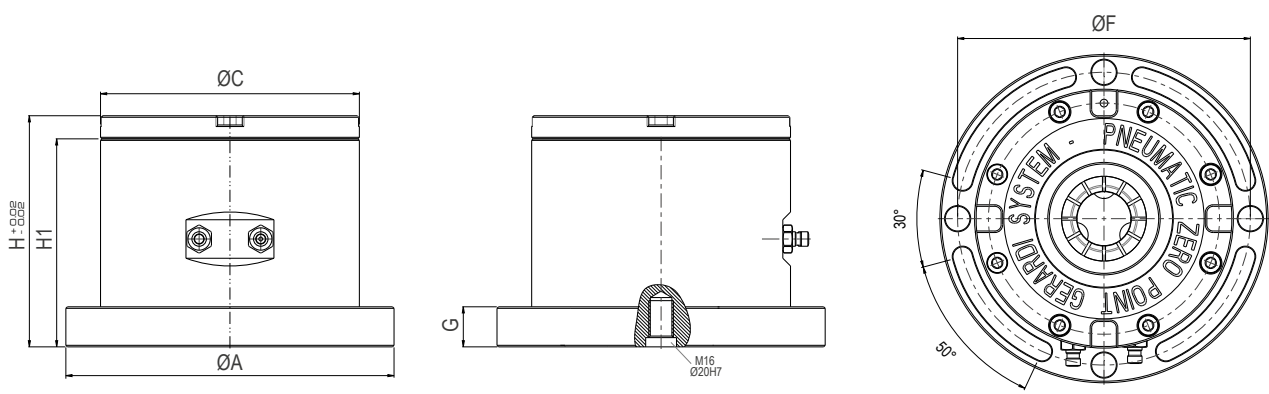

Art. 64 *Tipo / Type 1 e 2*

Rialzo doppio con Zero Point Art.665
Double riser with Zero Point Art.665

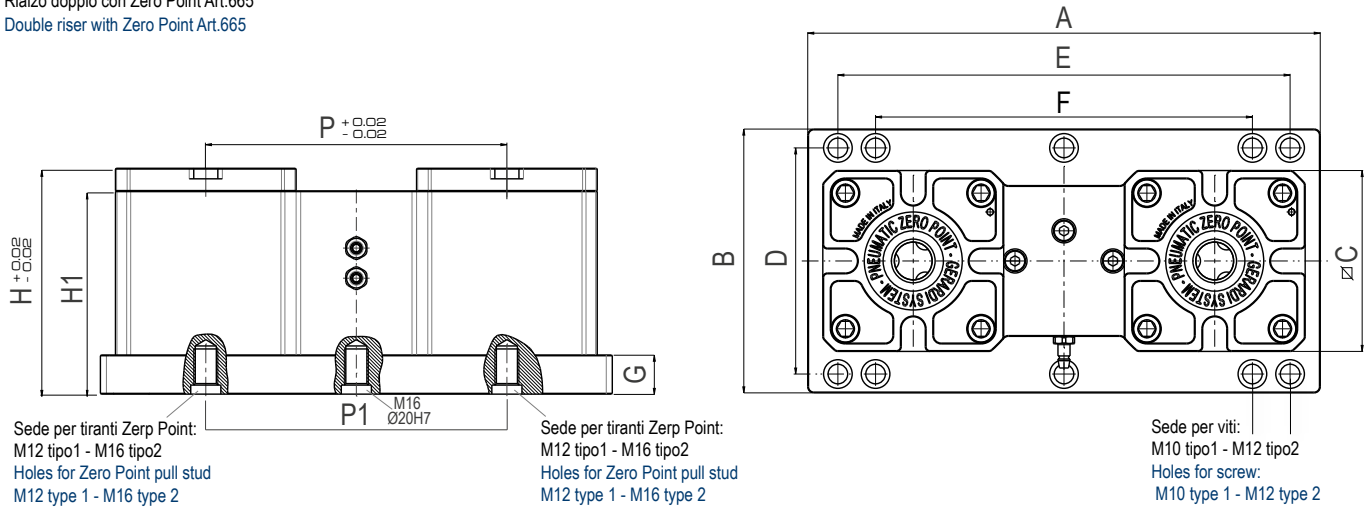

Sede per tiranti Zerp Point:
M12 tipo1 - M16 tipo2
Holes for Zero Point pull stud
M12 type 1 - M16 type 2

Sede per tiranti Zerp Point:
M12 tipo1 - M16 tipo2
Holes for Zero Point pull stud
M12 type 1 - M16 type 2

Sede per viti:
M10 tipo1 - M12 tipo2
Holes for screw:
M10 type 1 - M12 type 2

ZERO POINT DOPPIO

DOUBLE ZERO POINT

NEW!
Tipo (grandezza) / Type (size) **1**
Art. 665T *Tipo / Type 1*

 Zero Point doppio Art.665T
 Double Zero Point Art.665T

NEW!



kg	5,2
Cod.	9.66.5T100

Dotazione standard

- 1 tirante Art.10A / 11A
- 2 tappi teflon con O-Ring Art.9
- 1 tirante Art.11A

Standard equipment:

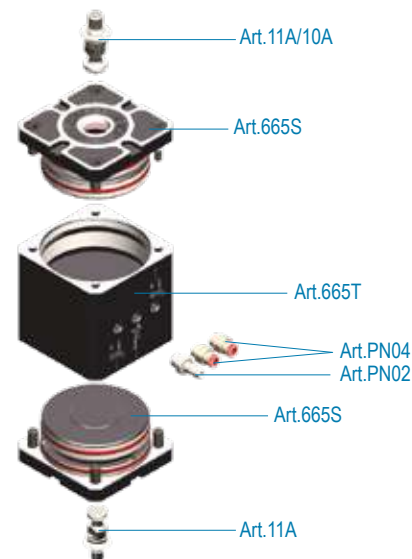
- 1 Pull-stud Art.10A / 11A
- 2 Teflon caps with O-Ring Art.9
- 1 Pull-stud Art.11A

Tipo (grandezza) / Type (size) **2**
Art. 665T *Tipo / Type 2*

 Zero Point doppio Art.665T
 Double Zero Point Art.665T

NEW!

kg	9,7
Cod.	9.66.5T200

Dotazione standard

- 1 tirante Art.10A / 11A
- 2 tappi teflon con O-Ring Art.9
- 1 tirante Art.11A

Standard equipment:

- 1 Pull-stud Art.10A / 11A
- 2 Teflon caps with O-Ring Art.9
- 1 Pull-stud Art.11A

Tipo (grandezza) / Type (size) **3**
Art. 665T *Tipo / Type 3*

 Zero Point doppio Art.665T
 Double Zero Point Art.665T

NEW!

kg	18,8
Cod.	9.66.5T300

Dotazione standard

- 1 tirante Art.10A / 11A
- 2 tappi teflon con O-Ring Art.9
- 1 tirante Art.11A

Standard equipment:

- 1 Pull-stud Art.10A / 11A
- 2 Teflon caps with O-Ring Art.9
- 1 Pull-stud Art.11A



ZERO POINT DOPPIO

DOUBLE ZERO POINT

NEW!

Art. 665T

Tipo / Type **1**

Zero Point doppio Art.665T
Double Zero Point Art.665T

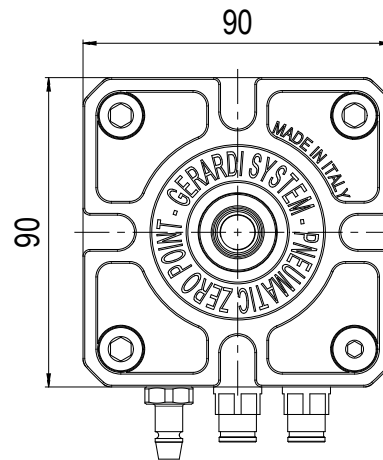
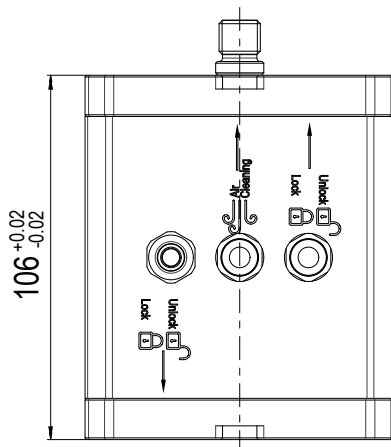

Art. 665T

Tipo / Type **2**

Zero Point doppio Art.665T
Double Zero Point Art.665T

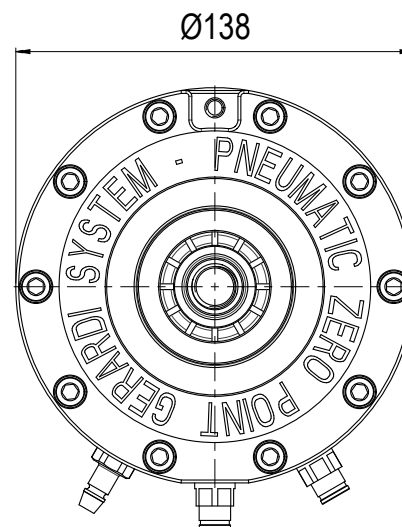
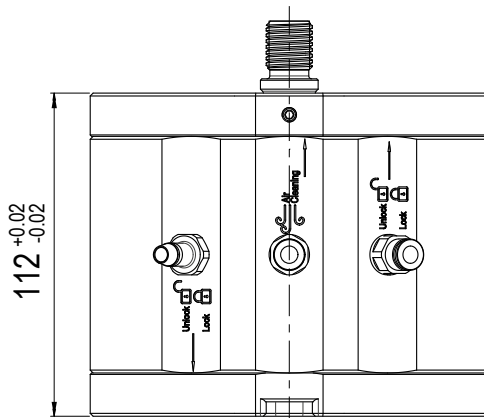

Art. 665T

Tipo / Type **3**

Zero Point doppio Art.665T
Double Zero Point Art.665T

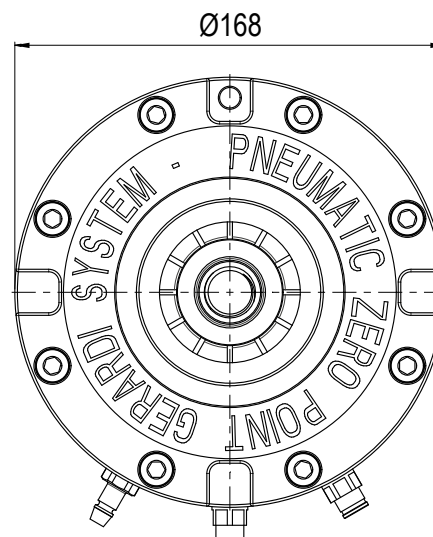
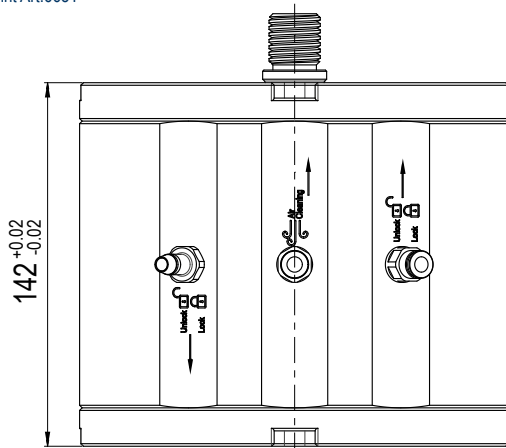

PORTAPEZZI IN GHISA CON ZERO POINT CAST IRON TOMBSTONES WITH ZERO POINT

Il sistema Zero Point Gerardi è predisposto per essere applicato all' ampia gamma di portapezzi, ampliando così la modularità del sistema Gerardi.
 In particolare:

The Gerardi Zero Point system has been designed to be used with the wide range of tombstones increasing in this way the modularity of the Gerardi system.
 In particular::

- Zero Point Pneumatico Art.665, montabile su portapezzi tramite l'utilizzo della flangia Art.665F

- Pneumatic Zero Point Art.665, can be assembled on tombstones through the Art.665F flange

Art. 665

Montaggio incassato
 Built-in mounting

- 665 T.1
- 665 T.2
- 665 T.3

Art. 665F

Flangia - Flange

- 665F T.1
- 665F T.2
- 665F T.3



Art. 665X

Montaggio verticale incassato con flangia
 Built-in vertical mounting with flange



	Type 1	Type 2	Type 3
Kg	3,2	5,8	-
Cod.	9.66.5X100	9.66.5X200	9.66.5X300

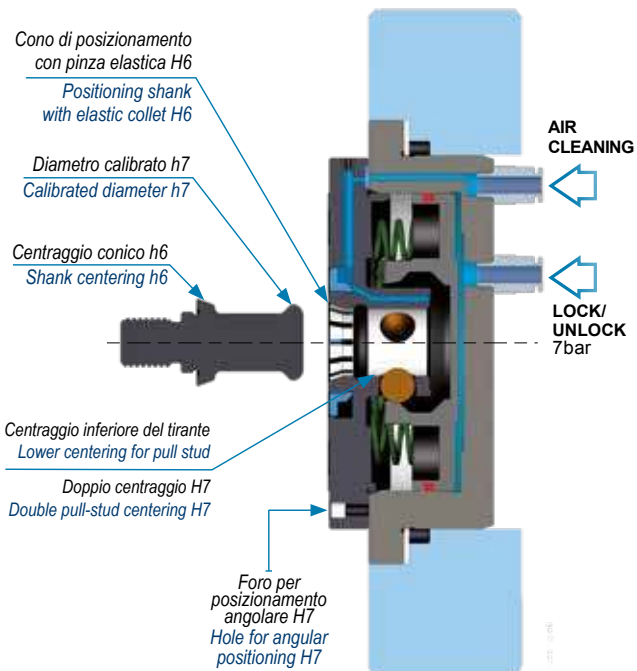

ESEMPIO: Art.53C CON PREDISPOSIZIONE PER 8 UNITÀ ZERO POINT TIPO 2 EXAMPLE: Art.53C WITH 8 SEATS FOR TYPE 2 ZERO POINT

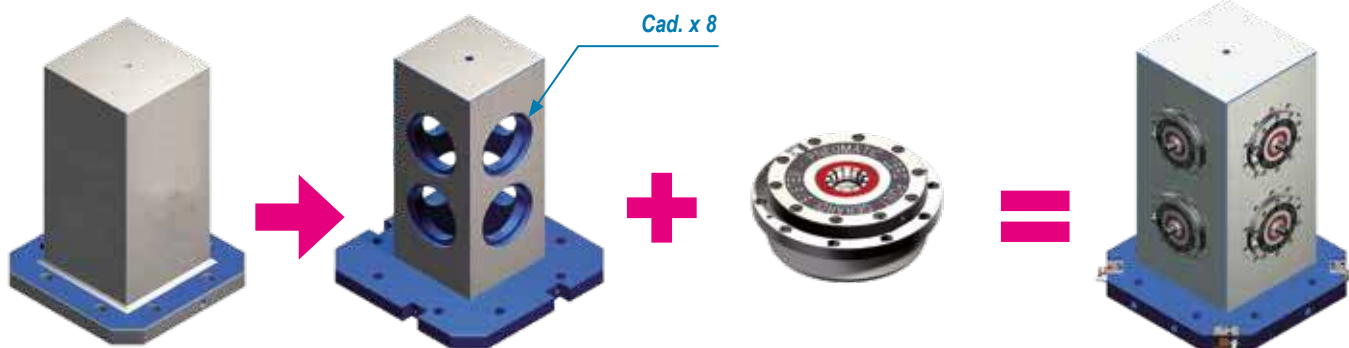

Art. 53C

Cod. 8.53.C00080
 Cubo completamente finito
 Cube completely finished

Art. 53C

Cod. 8.53.C00080
 Predisposizioni per 8 Zero Point
 Seats for 8 Zero Point

Art. 665X

Cod. 9.66.5X000
 8 Zero Point Art.665X
 8 Zero Point Art.665X

Art. 53P

Cod. 9.53.P00080
 Cubo con 8 Zero Point pneumatici Art.665X
 Cube with 8 pneumatic Zero Point Art.665X

ESEMPI DI APPLICAZIONI SU ZERO POINT

APPLICATION EXAMPLES WITH PNEUMATIC ZERO POINT



Zero Point pneumatico singolo Art.664S Tipo1 con morsa Art.650 Tipo 1x160
 Single pneumatic Zero Point Art.664S Type1 with vise Art.650 Type 1x160



Zero Point Pneumatico singolo Art.664S Tipo2 con morsa Art.640 Tipo 2
 Single pneumatic Zero Point Art.664S Type2 with vise Art.640 Type 2



Piastra Zero Point Art.81P
 con morsa Art.1 Tipo 3x200
 Zero Point plate Art.81P
 with vise Art.1 Type 3x200



Piastra Zero Point Art.81P
 con morsa Art.600 Tipo 2x500
 Zero Point plate Art.81P with
 vise Art.600 Type 2x500



Piastra Zero Point Art.81P
 con morsa Art.860 Tipo 3x500
 Zero Point plate Art.81P
 with vise Art.860 Type 3x500

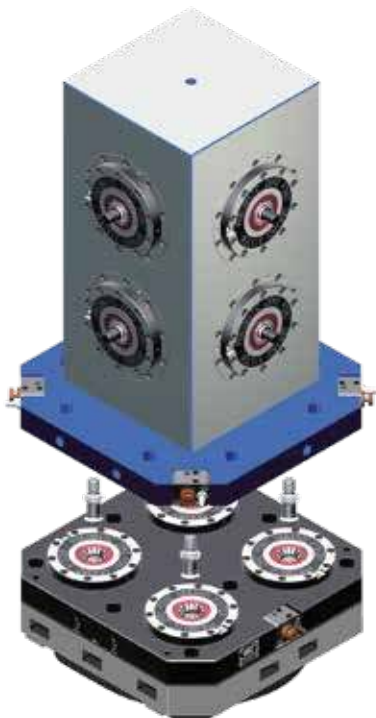

Piastra Zero Point Art.80P con cubo zero point Art.53P
 Zero Point plate Art.80P with zero point tombstone Art.53P



Piastra Zero Point Art.80P
 con piastra d' interfaccia Art.61i
 Zero Point plate Art.80P
 with base plate Art.61i



Zero Point Doppio tipo 2 Art.665T
 su piastra d' interfaccia Art.60F
 Double Zero Point type 2 Art.665T
 mounted on base plate Art.60F

PORTAPEZZI IN GHISA CON ZERO POINT INCASSATI CAST IRON TOMBSTONES WITH BUILT-IN ZERO POINT

Base lavorata e raschiata per pallet a norme Europee o Giapponesi.

Vedi specifiche a pagina 8.6

Base face machined and hand scraped for direct damping on European or Japanese standard pallet.

See specifications pag. 8.6

Art. 53P

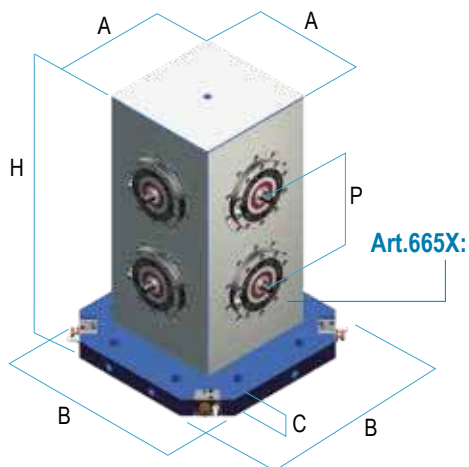

Gestione apertura Zero-Point indipendente per ogni lato.
Zero-Point opened from each sides independently.

Dimensioni - Dimensions

A	B	C	H	P	kg	Cod.
160	250	40	290	-	54	9.53.P00020
200	315	40	300	150	79	9.53.P00030
200	350	40	370	150	99	9.53.P00040
200	500	40	600	200	179	9.53.P00050
250	400	40	450	200	150	9.53.P00060
250	450	40	450	200	164	9.53.P00070
250	400	40	550	250	174	9.53.P00080
250	400	40	660	300	201	9.53.P00081
250	500	40	610	250	215	9.53.P00090
250	500	40	650	300	225	9.53.P00100
250	500	40	750	350	250	9.53.P00105
250	630	40	700	300	279	9.53.P00106
260	500	45	1000	450	311	9.53.P00107
270	400	40	510	200	176	9.53.P00110
300	500	40	600	250	247	9.53.P00111
300	500	40	750	350	293	9.53.P00113
300	500	40	900	400	338	9.53.P00115
330	500	40	660	300	288	9.53.P00120
350	500	40	410	200	212	9.53.P00140
350	500	40	450	200	226	9.53.P00150
350	500	40	550	250	263	9.53.P00160
350	500	40	610	250	284	9.53.P00170
350	500	40	700	300	317	9.53.P00171
350	630	40	700	300	359	9.53.P00172
350	630	40	820	350	402	9.53.P00180
350	630	40	950	450	450	9.53.P00185
450	630	40	550	250	367	9.53.P00190
450	630	40	650	300	415	9.53.P00200
500	630	40	860	400	565	9.53.P00211
550	750	40	850	400	656	9.53.P00220
500	800	40	800	350	600	9.53.P00230

Art. 54P

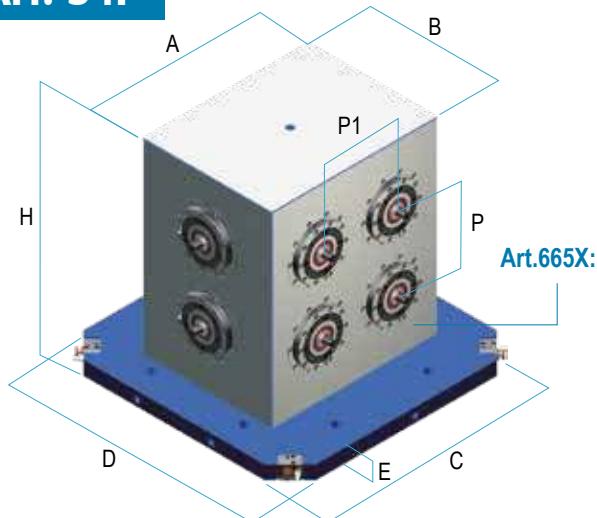

Gestione apertura Zero-Point indipendente per ogni lato.
Zero-Point opened from each sides independently.

Dimensioni - Dimensions

A	B	C	D	E	H	P	P1	kg	Cod.
300	200	450	300	40	360	160	-	127	9.54.P00010
350	250	400	400	40	550	250	160	205	9.54.P00040
350	250	500	500	40	750	350	160	292	9.54.P00070
300	200	400	400	40	550	250	-	174	9.54.P00080
450	350	630	630	40	550	250	200	336	9.54.P00100
450	350	630	630	40	650	300	200	340	9.54.P00110
550	350	630	630	40	650	300	300	413	9.54.P00120

Modelli normalmente presenti a magazzino

! Per lavorazioni o materiali diversi (alluminio), richiedere quotazione specifica - For different finishing and materials (aluminum), ask for specific quotation
(x) = n° Zero Point come da figura - (x) = n° Zero Point pieces shown in the image

PORTAPEZZI IN GHISA CON ZERO POINT INCASSATI CAST IRON TOMBSTONES WITH BUILT-IN ZERO POINT

Base lavorata e raschiata per pallet a norme Europee o Giapponesi.
Vedi specifiche a pagina 8.6

Base face machined and hand scraped for direct clamping on European or Japanese standard pallet.
See specifications pag. 8.6

Art. 55P

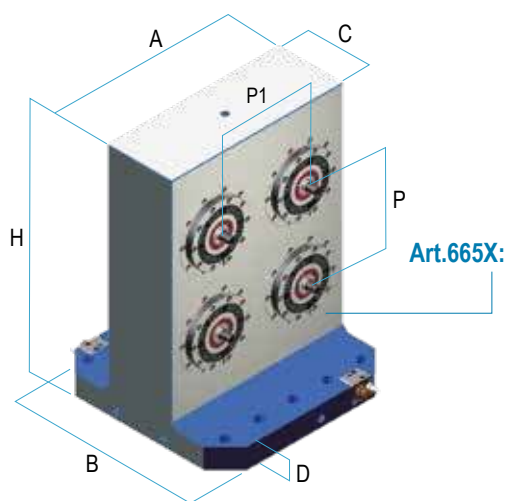

Art. 56P

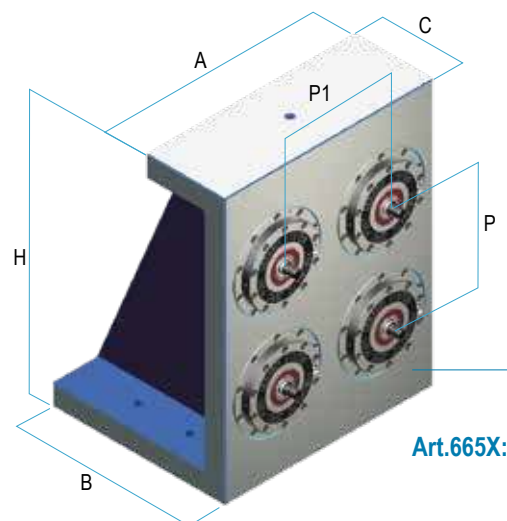

Dimensioni - Dimensions

A	B	C	D	H	P	P1	kg	Cod.
160	200	70	45	225	-	-	24	9.55.P00010
350	250	80	50	415	200	180	103	9.55.P00040
400	350	100	50	525	200	200	190	9.55.P00050
400	400	150	50	500	200	200	193	9.55.P00051
400	400	150	45	660	300	200	222	9.55.P00052
500	500	150	45	700	300	250	290	9.55.P00053
500	500	200	50	600	250	250	287	9.55.P00054
500	500	260	40	625	250	250	310	9.55.P00055
450	350	100	50	525	200	200	208	9.55.P00060
450	350	100	50	620	250	200	245	9.55.P00070
550	350	100	60	650	300	250	321	9.55.P00080
500	350	150	50	650	300	250	263	9.55.P00090
450	350	150	50	610	250	200	250	9.55.P00120
450	350	150	50	750	350	200	271	9.55.P00125
550	350	150	60	670	300	250	303	9.55.P00150
550	450	150	50	820	350	250	369	9.55.P00160
630	450	150	50	820	350	300	418	9.55.P00170
630	450	250	60	900	400	300	508	9.55.P00171
630	630	200	50	850	400	300	504	9.55.P00172
630	630	250	50	700	300	300	447	9.55.P00173
350	450	150	60	650	300	180	213	9.55.P00180
800	450	150	60	850	400	400	555	9.55.P00190
800	800	300	50	800	350	400	674	9.55.P00191
800	800	200	50	1000	250	250	-	9.55.P00192

Dimensioni - Dimensions

A	B	C	H	P	P1	kg	Cod.
350	150	40	250	-	160	42	9.56.P00008
300	220	100	300	-	160	57	9.56.P00009
350	230	100	360	160	160	75	9.56.P00010
400	280	100	400	200	200	100	9.56.P00011
400	330	150	510	250	200	140	9.56.P00030
500	340	150	500	250	250	166	9.56.P00031
450	330	150	460	200	200	142	9.56.P00040
450	330	150	610	300	200	174	9.56.P00050
630	435	150	630	300	300	262	9.56.P00051
500	230	100	360	160	250	101	9.56.P00060
550	430	200	810	400	250	298	9.56.P00080
650	330	150	660	300	300	245	9.56.P00100
200	300	50	700	350	-	90	9.56.P00101
800	330	150	560	250	400	266	9.56.P00110
800	525	200	800	400	400	452	9.56.P00111
800	430	200	800	400	400	402	9.56.P00120

Available usually immediately

! Per lavorazioni o materiali diversi (alluminio), richiedere quotazione specifica - For different finishing and materials (aluminum), ask for specific quotation
(x) = n° Zero Point come da figura - (x) = n° Zero Point pieces shown in the image

TIRANTI TIPO 1

PULL-STUD TYPE 1

Il fissaggio ed il posizionamento delle attrezzature, o del particolare da lavorare, si effettua tramite i tiranti **Art.10** e **Art.11**
 The clamping and the positioning of the fixtures, or directly the workpiece, is done through pull-studs **Art.10** and **Art.11**

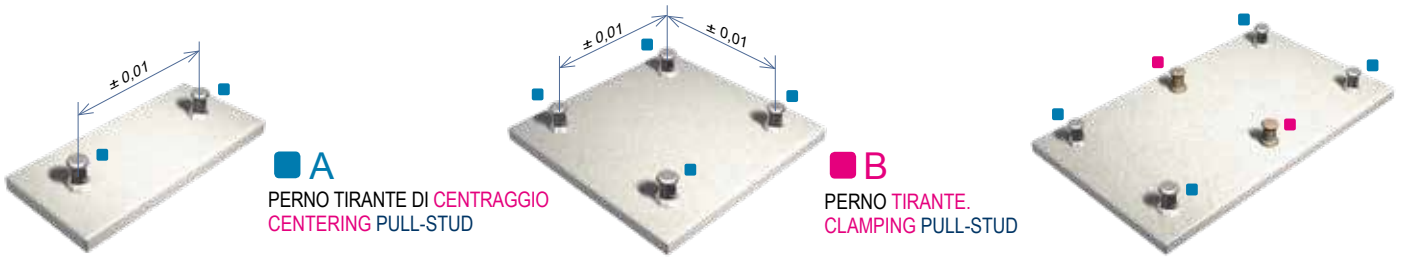

A
 PERNO TIRANTE DI CENTRAGGIO
 CENTERING PULL-STUD

B
 PERNO TIRANTE.
 CLAMPING PULL-STUD

Il tipo "A" si utilizza per il centraggio e il serraggio, mentre il tipo "B" solo per il serraggio
 Type "A" is used for both centering and clamping, while type "B" is only for clamping

Art. 10A

Perno tirante di centraggio. Filetto femmina
 Centering pull-stud. Female thread

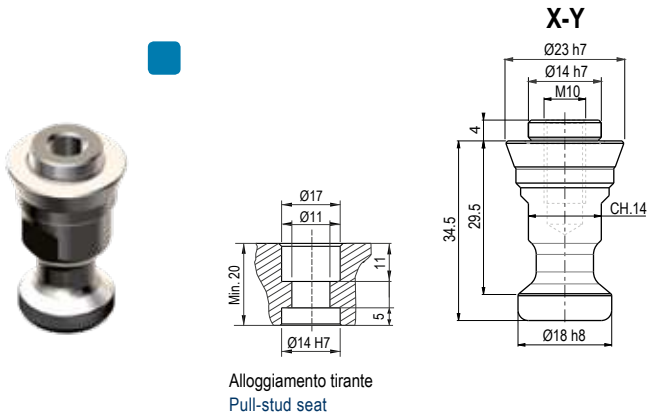

Alloggiamento tirante
 Pull-stud seat

Cod. 9.10.A1000

Art. 10B

Perno tirante. Filetto femmina
 Clamping pull-stud. Female thread

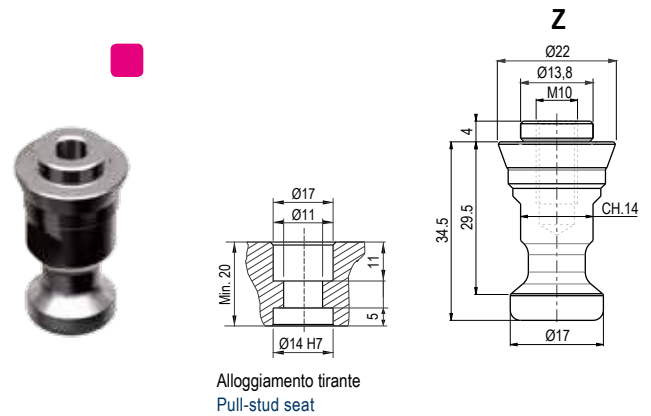

Alloggiamento tirante
 Pull-stud seat

Cod. 9.10.B1000

Art. 11A

Perno tirante di centraggio. Filetto maschio
 Centering pull-stud. Male thread

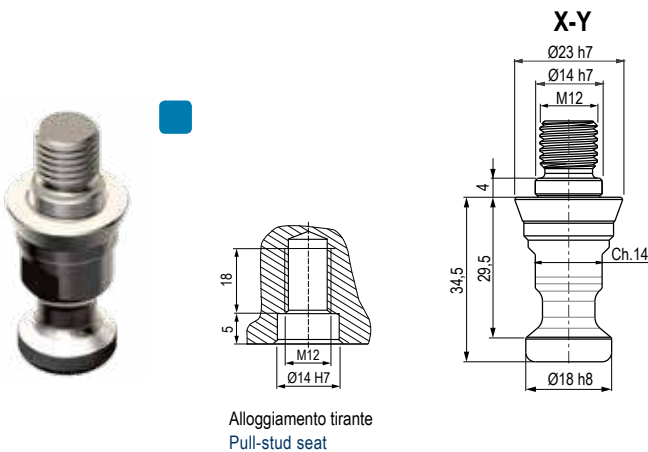

Alloggiamento tirante
 Pull-stud seat

Cod. 9.11.A1000

Art. 11B

Perno tirante. Filetto maschio
 Clamping pull-stud. Male thread

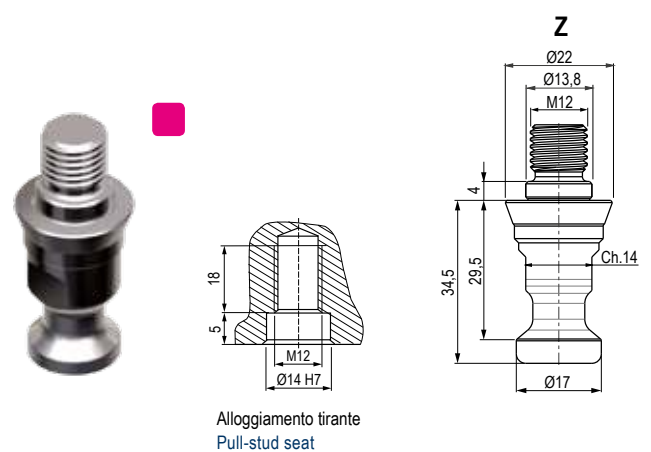

Alloggiamento tirante
 Pull-stud seat

Cod. 9.11.B1000

TIRANTI TIPO 2 PULL-STUD TYPE 2

Il fissaggio ed il posizionamento delle attrezzature, o del particolare da lavorare, si effettua tramite i tiranti **Art.10** e **Art.11**
The clamping and the positioning of the fixtures, or directly the workpiece, is done through pull-studs **Art.10** and **Art.11**

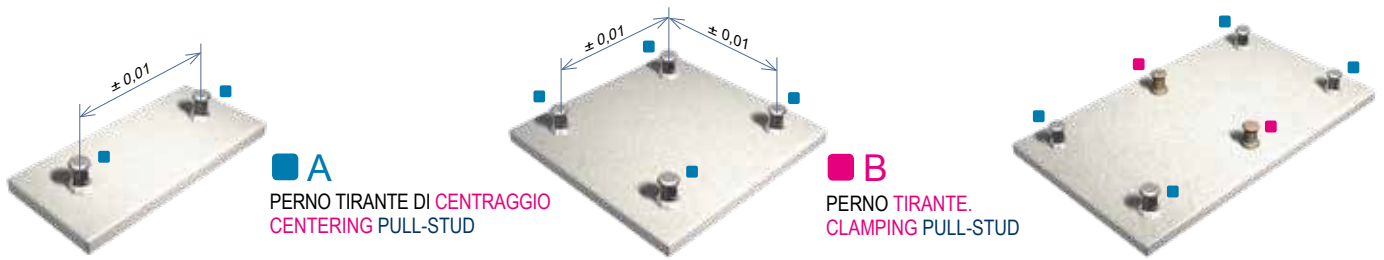

A
PERNO TIRANTE DI **CENTRAGGIO**
CENTERING PULL-STUD

B
PERNO TIRANTE.
CLAMPING PULL-STUD

Il tipo "A" si utilizza per il centraggio e il serraggio, mentre il tipo "B" solo per il serraggio
Type "A" is used for both centering and clamping, while type "B" is only for clamping

Art. 10A

Perno tirante di **centraggio**. Filetto femmina
Centering pull-stud. Female thread

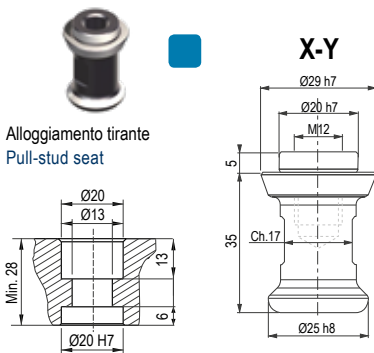

Disponibile con sede TIPO 1 (Ø14h7 / M10)
Available with TYPE 1 hole (Ø14h7 / M10)

Cod. 9.10.A2000

Art. 10B

Perno **tirante**. Filetto femmina
Clamping pull-stud. Female thread

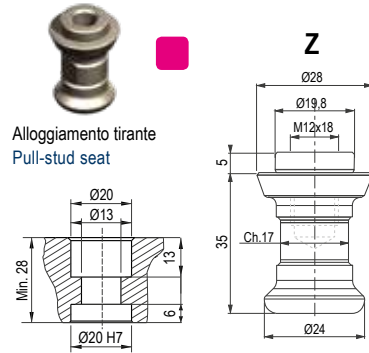

Cod. 9.10.B2000

Art. 10S

Perno tirante di **centraggio** per Zero Point **singolo**. Filetto femmina
Centering pull-stud for **single** Zero Point. Female thread

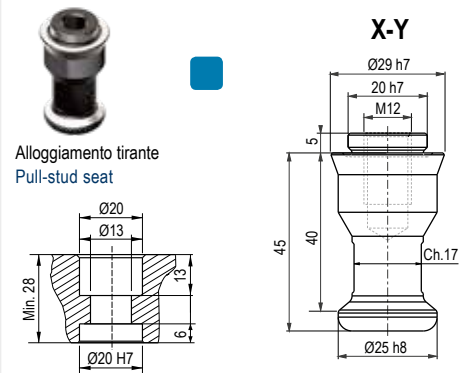

Disponibile con sede TIPO 1 (Ø14h7 / M10)
Available with TYPE 1 hole (Ø14h7 / M10)

Cod. 9.10.S2000

Art. 11A

Perno tirante di **centraggio**. Filetto maschio
Centering pull-stud. Male thread

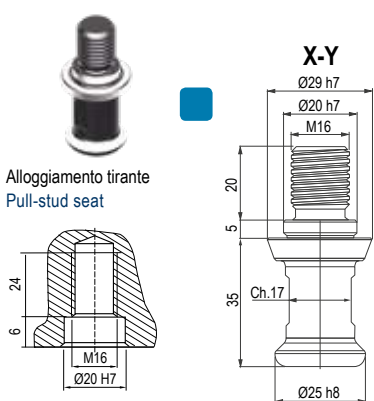

Cod. 9.11.A2000

Art. 11B

Perno **tirante**. Filetto maschio
Clamping pull-stud. Male thread

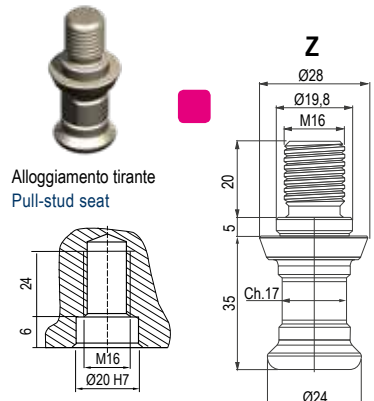

Cod. 9.11.B2000

Art. 11S

Perno tirante di **centraggio** per Zero Point **singolo**. Filetto maschio
Centering pull-stud for **single** Zero Point. Male thread

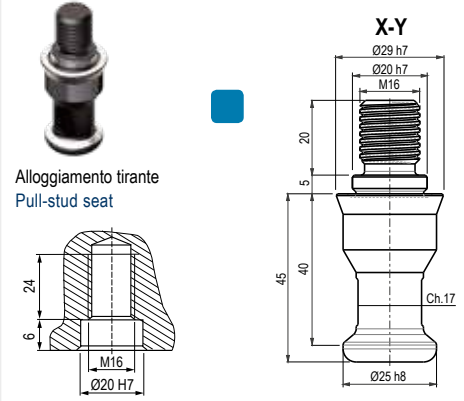

Cod. 9.11.S2000

TIRANTI TIPO 3

PULL-STUD TYPE 3

NEW!

Il fissaggio ed il posizionamento delle attrezzature, o del particolare da lavorare, si effettua tramite i tiranti **Art.10** e **Art.11**
 The clamping and the positioning of the fixtures, or directly the workpiece, is done through pull-studs **Art.10** and **Art.11**

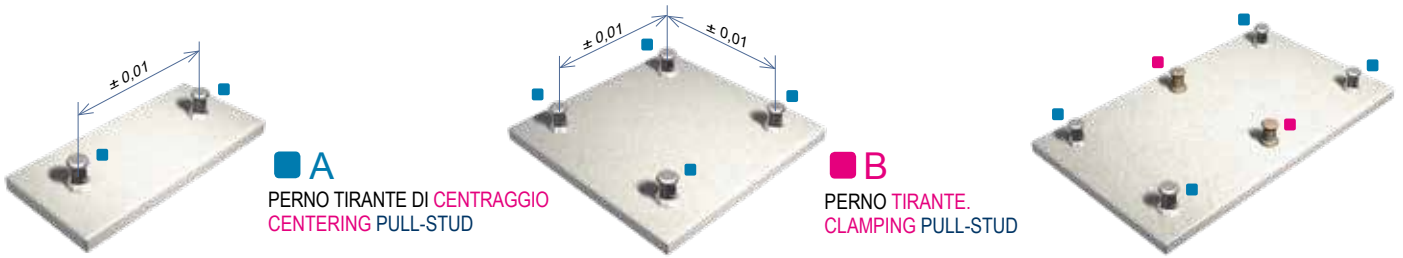

A
 PERNO TIRANTE DI CENTRAGGIO
 CENTERING PULL-STUD

B
 PERNO TIRANTE.
 CLAMPING PULL-STUD

Il tipo "A" si utilizza per il centraggio e il serraggio, mentre il tipo "B" solo per il serraggio
 Type "A" is used for both centering and clamping, while type "B" is only for clamping

Art. 10A

Perno tirante di centraggio. Filetto femmina
 Centering pull-stud. Female thread

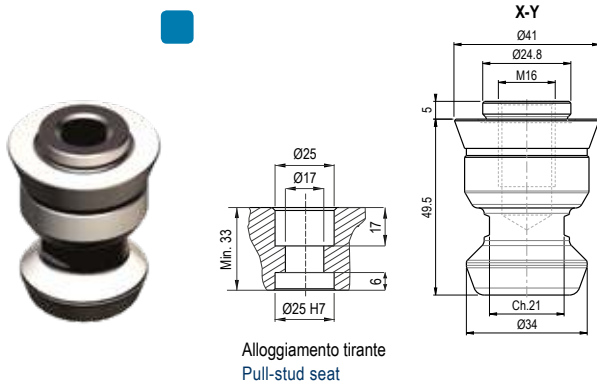

Alloggiamento tirante
 Pull-stud seat

Cod. 9.10.A3000

Art. 10B

Perno tirante. Filetto femmina
 Pull-stud. Female thread

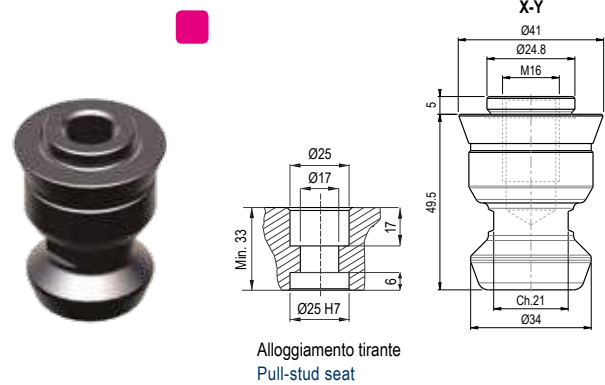

Alloggiamento tirante
 Pull-stud seat

Cod. 9.10.B3000

Art. 11A

Perno tirante di centraggio. Filetto maschio
 Centering pull-stud. Male thread

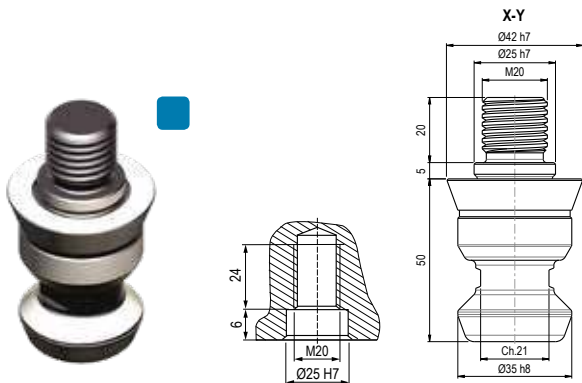

Alloggiamento tirante
 Pull-stud seat

Cod. 9.11.A3000

Art. 11B

Perno tirante. Filetto maschio
 Pull-stud. Male thread

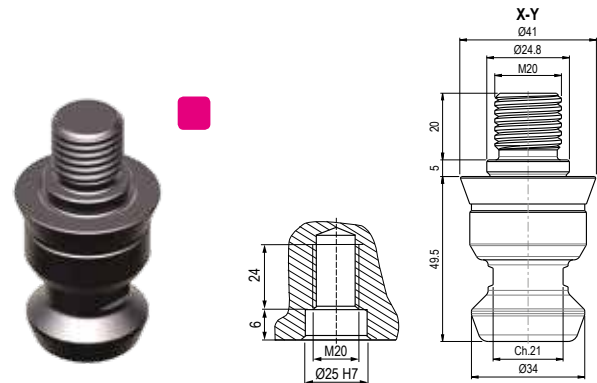

Alloggiamento tirante
 Pull-stud seat

Cod. 9.11.B3000

KIT COMPLETO PER AZIONAMENTO PIASTRA (O CUBO) CON ZERO POINT COMPLETE KIT FOR ZERO POINT PLATE (OR CUBE) CONTROL

Art. 409

Cod. 9.40.90000

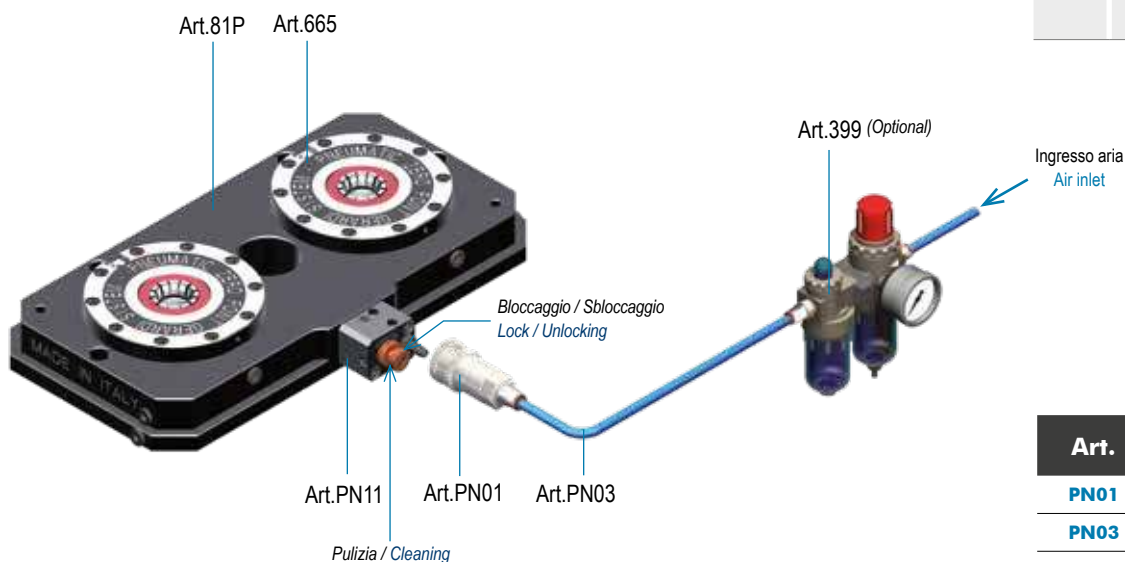

Art.	Pag.
PN01	9.38
PN03	9.38
PN11	9.38

Art. 399 - Opzionale - Optional (Pag 9.39)

KIT COMPLETO per AZIONAMENTO più PIASTRE (O CUBI) con ZERO POINT COMPLETE KIT for MULTIPLE ZERO POINT PLATES (OR CUBES) CONTROL

Art. 409B

Cod. 9.40.9B000

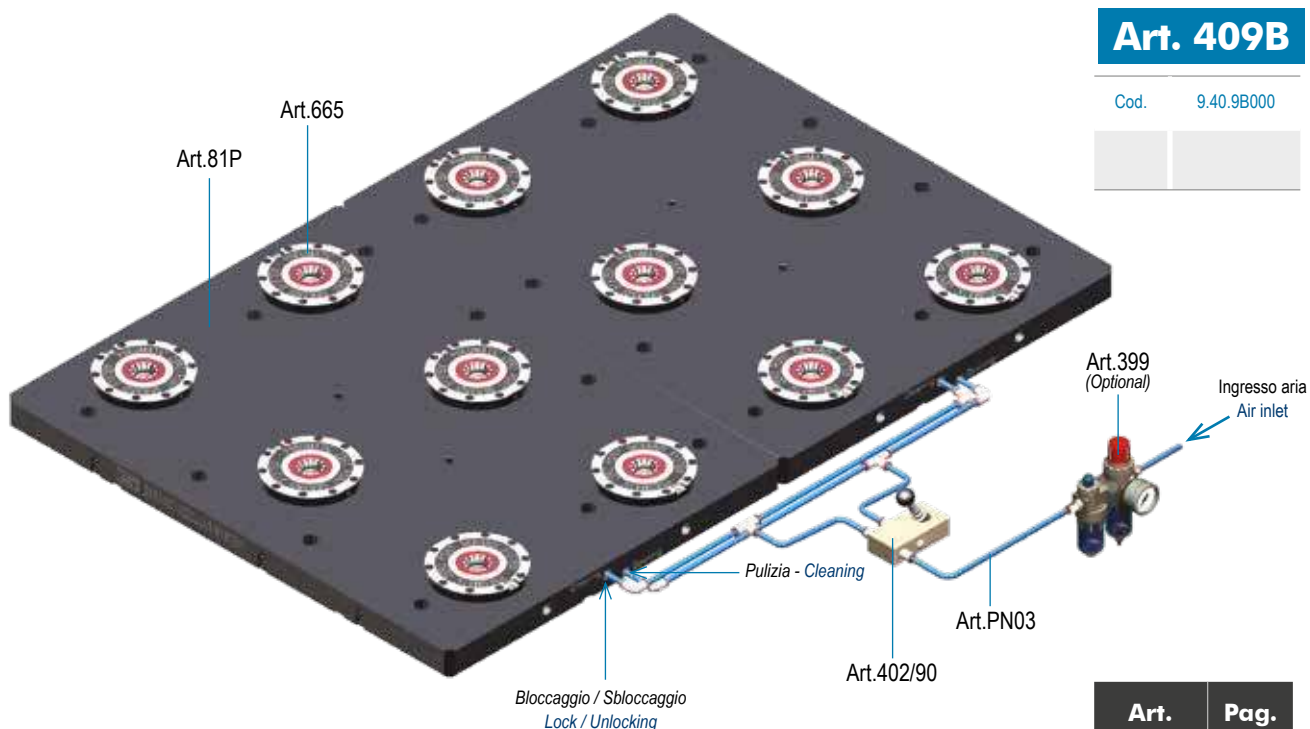















Art.	Pag.
PN03	9.38
402/90	9.39

- Attacco rapido Art.PN01 a richiesta (o da ordinare con Art.PN02)
- Quick connection Art.PN01 on request (to be ordered with Art.PN02)

Art. 399 - Opzionale - Optional (Pag 9.39)

ACCESSORI & RACCORDI per ZERO POINT PNEUMATICI

ACCESSORIES & CONNECTIONS FOR PNEUMATIC ZERO POINT

		Cod.	
Art. PN01		9.PN.01000	
Attacco rapido femmina Female connection			
Art. PN02		9.PN.02000	
Innesto rapido maschio - 1/8" Gas Quick male coupling - 1/8" Gas			
Art. PN03		9.PN.03000	
Tubo pneumatico aria Ø8 Pneumatic air pipe Ø8			
Art. PN04		9.PN.04000	
Raccordo diritto cilindrico maschio Ø8 - 1/8" Gas Straight male adaptor Ø8 - 1/8" Gas			
Art. PN05		9.PN.05000	
Tappo 1/8" Gas Cap 1/8" Gas			
Art. PN06		9.PN.06000	
Raccordo a "L" maschio cilindrico girevole Ø8 - 1/8" Gas "L" rotary male adaptor parallel Ø8 - 1/8" Gas			
Art. PN07		9.PN.07000	
Raccordo a "T" centrale maschio cilindrico girevole Ø8 - 1/8" Gas "T" rotary parallel adaptor Ø8 - 1/8" Gas			
Art. PN08		9.PN.08000	
Riduzione Ø8 Reducer Ø8			
Art. PN09		9.PN.09000	
Tappo Ø8 Cap Ø8			
Art. PN10		9.PN.10000	
Blocchetto di connessione con innesto rapido - 1/8" Gas Connection block with quick male coupling - 1/8" Gas			
Art. PN11		9.PN.11000	
Blocchetto di connessione con innesto rapido - 1/8" Gas Connection block with quick male coupling - 1/8" Gas			
Art. PN13 NEW!		9.PN.13000	
Attacco rapido femmina per versioni con doppio effetto Female connection for double effect version			
Art. PN14 NEW!		9.PN.14000	
Innesto rapido maschio - 1/4" Gas per versioni con doppio effetto Quick male coupling - 1/4" Gas for double effect version			
Art. PN15 NEW!		9.PN.15000	
Innesto rapido valvolato maschio - 1/4" Gas per versioni con doppio effetto Quick male valved coupling - 1/4" Gas for double effect version			

ACCESSORI & RACCORDI PER ZERO POINT

ACCESSORIES & CONNECTIONS FOR ZERO POINT

		Cod.	
Art. PN18 NEW! Valvola pneumatica a 1 via con comando elettrico One way pneumatic valve with electrical control		Campi di regolazione BAR Setting range BAR 1 - 10	9.PN.18010
		Campi di regolazione BAR Setting range BAR 10 - 25	9.PN.18025
Art. PN20 NEW! Valvola pneumatica a 5 vie con comando elettrico Five ways pneumatic valve with electrical control			9.PN.2000/5
Art. PN21 NEW! Valvola pneumatica a 3 vie con comando elettrico Three ways pneumatic valve with electrical control			9.PN.2100/3
Art. 9 Tappo teflon con O-Ring Teflon Cap with O-Ring			9.09.10000
Art. 399 Gruppo filtro riduttore più lubrificatore Compressed air preparation unit			4.39.90000
Art. 400 Pedale bistabile Two position foot pedal			4.40.00000
Art. 402 Valvola pneumatica frontale, 2 vie Frontal pneumatic valve, 2 ways			4.40.20000
Art. 402/90 Distributore leva angolare a 90°, 3 vie 90° angular valve, 3 ways			9.40.29000
Art. 408 Moltiplicatore di pressione aria. Completo di manometro e valvola. Il sistema deve utilizzare aria essiccata e lubrificata (Art.399 opzionale) Pressure air multiplier. Complete of pressure gauge and valve. The sytem should be used with dry and lubricated air (option Art.399)			9.40.80000

DIVISORE AUTOMATICO DPG 250

AUTOMATIC DIVIDING HEAD DPG 250

NEW!
Divisore automatico
 Automatic dividing head



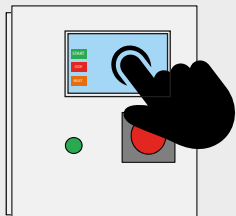
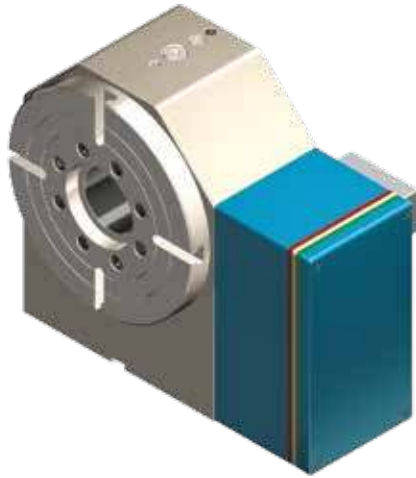



Dati tecnici
 Technical Data

DPG 250

PROGRAMMAZIONE TOUCH SCREEN
 FACILE ED INTUITIVA O TRAMITE COLLEGAMENTO
 DIRETTO AL CNC

EASY AND INTUITIVE TOUCH SCREEN
 PROGRAMMING OR THROUGH DIRECT
 CONNECTION TO THE CNC

- Installazione semplice (alimentazione 220V)
- Corona in bronzo speciale
- Controsupporto semplice
- Vite senza fine in acciaio temprato e rettificato
- Vite e corona in bagno d'olio
- Cuscinetti a vite precaricati
- Cuscinetto anteriore a rulli incrociati sovradimensionato
- Recupero gioco con avvicinamento assiale
- Completa tenuta stagna ai liquidi con possibilità di pressurizzazione
- Possibilità di montare motori di tutte le marche
- Dimensioni esterne contenute
- Finestra di controlli liquidi e condensa
- Lavorazione in posizionamento a 360°

- Easy installation (220V)
- Special bronze crown
- Simple tailstock
- Worm screw in hardened ground steel
- Bath lubrication Screw and Crown
- Pre-loaded screw bearings
- Over-dimensioned crossed-roller front bearing
- Play recover with axial approach
- Watertight seal with possibility of pressurization
- Possibility to mount motors of all brands
- Reduced external dimensions
- Condensation and liquid control window
- 360° work positioning

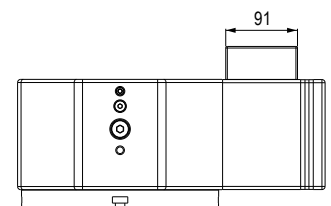
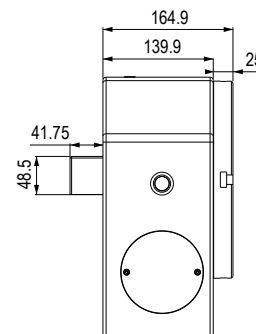
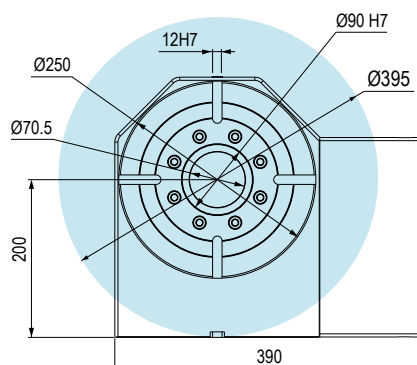
Diametro del divisore Dividing head diameter		250 mm
Diametro del foro passante Clearance hole diameter		70,5 mm
Altezza punta Center height		200 mm
Dimensione della scanalatura a T T-Slot width		12 mm
Sistema di bloccaggio Clamping system		Idrraulico Hydraulic
Forza frenante Clamping torque		3000 Nm
Motore Servo motor		3000 Max.g/min
Minimo incremento Minimum increment		0,002
Velocità di rotazione Rotation speed		33,3 Giri/min
Rapporti vite/corona Speed reduction ratio (screw/gear)		1/90
Rapporti vite/motore Speed reduction ratio (screw/motor)		1/180
Precisione Indexing accuracy		±10 Sec.
Ripetibilità Repeatability		4 Sec.
Max. carico di lavoro sul divisore Max. allowable work weight on the dividing head	Verticale Vertical	 Kg.550
	Orizzontale Horizontal	 Kg.1500
Max. carico di spinta applicabile sul divisore Max. allowable tool load on the dividing head		 N 25000
		 FxL Nm 1000
		 FxL Nm 2200
Rapporti vite/corona Speed reduction ratio (screw/gear)	Verticale Vertical	 10,5 Kg. m ²
Coppia in lavoro Driving torque	Corona dentata Worm gear	 698 Nm
Kg		110
Cod.		8.DP.G2500

DPG 250

Tipo (grandezza) morsa / Vise type (size)		1	2
Pressione Apertura / Open pressure	BAR	7	7
Divisore Gerardi DPG250 con piastra zero-point per cambio rapido	A	90	Ø138
	C	12	15
Forma Shape			
Cod.		9.66.5S100	9.66.52000

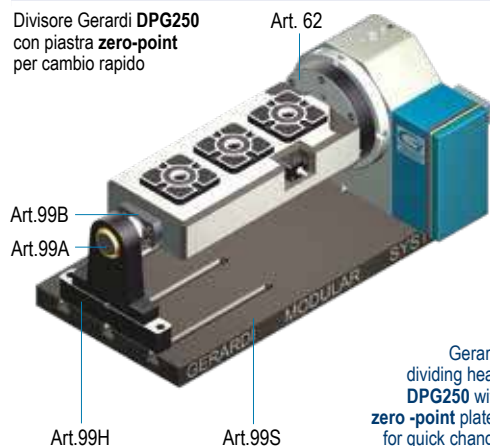

Gerardi dividing head DPG250 with zero-point plates for quick change

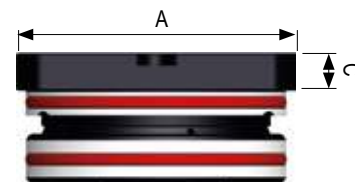
 Chiavette o fori calibrati su richiesta
 Keyways or calibrated holes on request

UPGRADE YOUR VISE APPLICATIONS THROUGH MODULAR ACCESSORIES !
Art. 99A

 Supporto
 Support

Cod. 7.99.A1000

Art. 99B

 Perno di centraggio orizzontale
 Horizontal centering pin

Cod. 7.99.B1000

Art. 99H

 Distanziale
 Spacer



Cod. 7.99.H1000

Art. 62
DPG 250

 Piastra di interfaccia DPG 250 per Zero Point
 DPG 250 connecting plate for Zero Point

Cod. 9.62.804A05

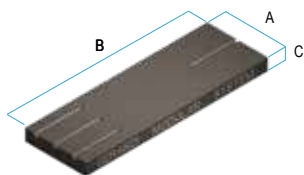
Art. 99S

 Piastra base con cave
 Piani rettificati
 Base plate with slot
 Faces ground

 Cave o fori calibrati su richiesta
 Slot or ground holes on request

Dimensioni B mm Dimension B mm	A	C	Kg	Cod.
900	400	50	141	7.99.S090S
1100	400	50	172	7.99.S110S
1300	400	50	-	7.99.S130S

Disponibili quote "B" a step di 50mm - Available dimension "B" in steps of 50mm

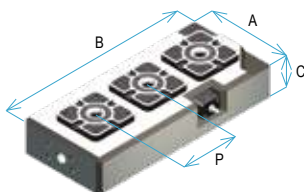
Art. 99R

 Piastra con Zero-Point
 incassati
 Plate with built-in Zero-Point

Dimensioni B mm Dimension B mm	A	C	P	Kg	Cod.
600	220	100	200	103	9.99.R0656
800	220	100	200	138	9.99.R0856
1000	220	100	200	172	9.99.R1056

Art. 99Q

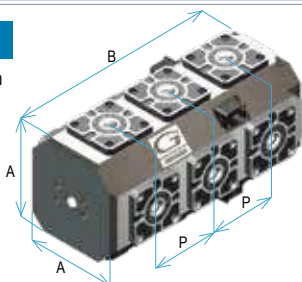
 Cubo portapezzi con
 Zero-Point incassati
 Tombstones with
 built-in Zero-Point

Dimensioni B mm Dimension B mm	A	P	Kg	Cod.
600	220	200	227	9.99.Q6512
800	220	200	303	9.99.Q8512
1000	220	200	378	9.99.Q1512

Art. 99A

 Supporto cubo portapezzi
 Tombstone support

Cod. 5.99.A2000

Art. 99H

 Distanziale maggiorato
 Bigger spacer

Cod. 5.99.H2000

 Per soluzioni alternative a quelle standard contattare il nostro ufficio tecnico
 For alternative solutions please contact our technical department

DIVISORE MECCANICO DIVIGER 205

MECHANICAL DIVIDING HEAD DIVIGER 205

NEW!
Divisore automatico
 Automatic dividing head

Dati tecnici
 Technical Data

DIVIGER 205

Diametro del divisore Dividing head diameter	220 mm
Diametro del foro passante Clearance hole diameter	85 mm
Altezza centrale Center height	200 mm
Dimensione della scanalatura a T T-Slot width	-
Sistema di bloccaggio Clamping system	Meccanico Mechanical
Minimo incremento Minimum increment	1°
Precisione Indexing accuracy	±10 Sec.
Coppia in lavoro Driving torque	 3000 Nm
Kg	93
Cod.	7.66.73000

 DIVISORE MECCANICO, SENZA CAVI O IDRAULICA,
 PERMACCHINE A CNC

 MECHANICAL DIVIDING HEAD, WITHOUT ELECTRICAL CABLES
 OR HYDRAULIC, FOR CNC MILLING MACHINE

- Maggiore efficienza nella lavorazione su più lati
- Completamente autonomo dalla macchina
- Elevato momento torcente
- Divisione manuale o automatica tramite mandrino macchina
- 360 posizioni
- Serraggio simultaneo di due particolari grazie alla doppia flangia
- lavorazione su 5 facce senza contropunta
- Lavorazione a barra grazie al mandrino cavo
- Utilizzabile orizzontalmente o verticalmente
- Cambio tramite serraggio a cuneo
- Cost-effective on multiple-sides machining
- Machine independent
- High holding torque
- Dividing manually or automatically using the machine spindle
- 360 x 1° division
- Simultaneous clamping of 2 workpieces thanks to the dual flange
- 5 faces machining without counter-holder
- Bar machining due to hollow spindle
- To be used horizontally or vertically
- Quick change through wedge clamping

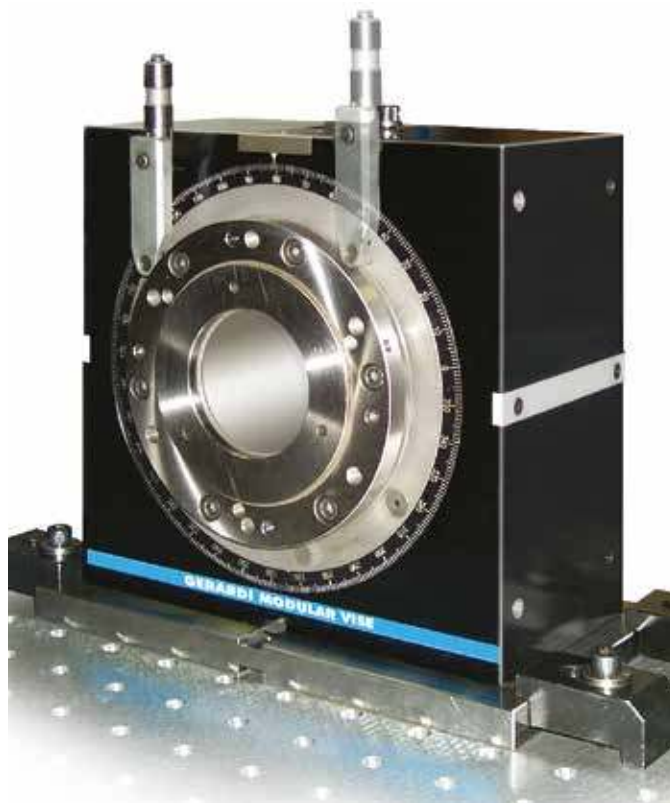
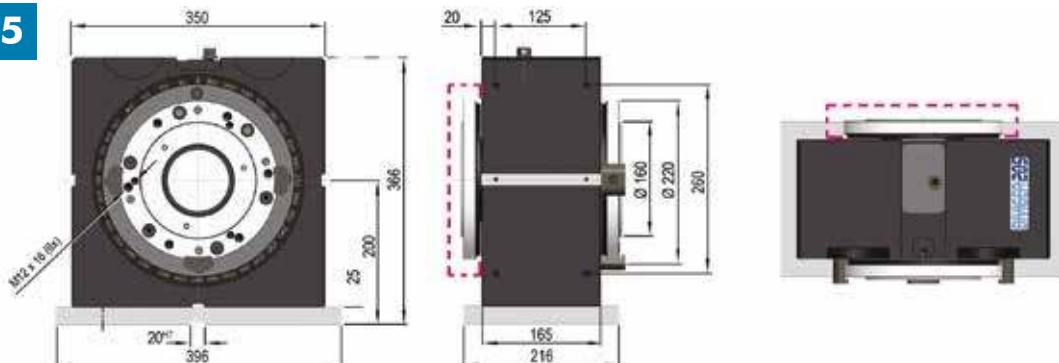
DIVIGER 205

Tipo (grandezza) morsa / Vise type (size)		1	2
Pressione Apertura / Open pressure	BAR	7	7
Tavola girevole Gerardi DIVIGER 205 con piastra zero-point per cambio rapido	A	90	Ø138
	C	12	15
Forma Shape			
Cod.		9.66.5S100	9.66.52000

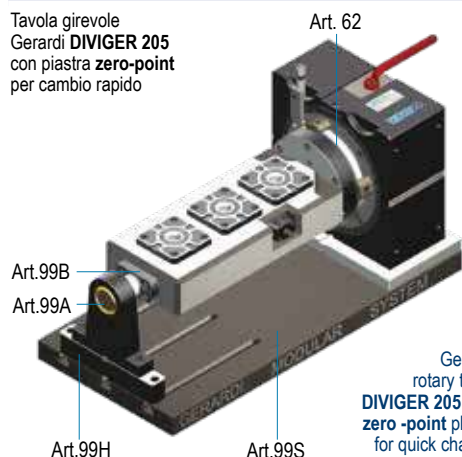
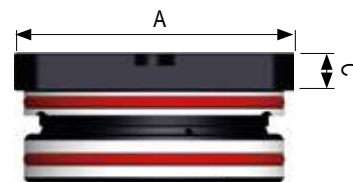
 Gerardi rotary table **DIVIGER 205** with **zero-point** plates for quick change

Chiavette o fori calibrati su richiesta
 Keyways or calibrated holes on request

UPGRADE YOUR VISE APPLICATIONS THROUGH MODULAR ACCESSORIES !
Art. 99A

 Supporto
 Support

Cod. 7.99.A1000

Art. 99B

 Perno di centraggio orizzontale
 Horizontal centering pin

Cod. 7.99.B1000

Art. 99H

 Distanziale
 Spacer



Cod. 7.99.H1000

Art. 62
DIVIGER 205

 Piastra di interfaccia DIVIGER 205 per Zero Point
 DIVIGER 205 connecting plate for Zero Point

Cod. 9.62.804A05

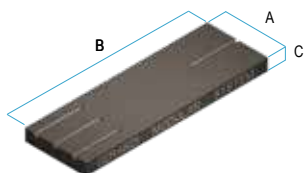
Art. 99S

 Piastra base con cave
 Piani rettificati
 Base plate with slot
 Faces ground

 Cave o fori calibrati su richiesta
 Slot or ground holes on request

Dimensioni B mm Dimension B mm	A	C	Kg	Cod.
900	400	50	141	7.99.S090S
1100	400	50	172	7.99.S110S
1300	400	50	-	7.99.S130S

Disponibili quote "B" a step di 50mm - Available dimension "B" in steps of 50mm

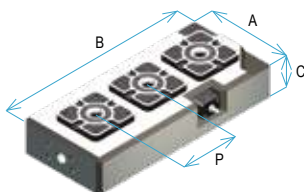
Art. 99R

 Piastra con Zero-Point
 incassati
 Plate with built-in
 Zero-Point

Dimensioni B mm Dimension B mm	A	C	P	Kg	Cod.
600	220	100	200	103	9.99.R0656
800	220	100	200	138	9.99.R0856
1000	220	100	200	172	9.99.R1056

Art. 99Q

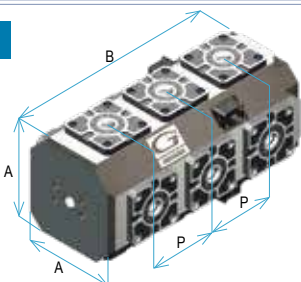
 Cubo portapezzi con
 Zero-Point incassati
 Tombstones with
 built-in Zero-Point

Dimensioni B mm Dimension B mm	A	P	Kg	Cod.
600	220	200	227	9.99.Q6512
800	220	200	303	9.99.Q8512
1000	220	200	378	9.99.Q1512

Art. 99A

 Supporto cubo portapezzi
 Tombstone support

Cod. 5.99.A2000

Art. 99H

 Distanziale maggiorato
 Bigger spacer

Cod. 5.99.H2000

 Per soluzioni alternative a quelle standard contattare il nostro ufficio tecnico
 For alternative solutions please contact our technical department

ESEMPI di APPLICAZIONE ZERO POINT

ZERO POINT APPLICATION EXAMPLES for INTERFACE PLATES



Zero Point indipendenti (Art.664) con carter di copertura in acciaio inox
Independents Zero Point (Art.664) with cover plates steel inox



Attrezzatura speciale con Zero Point applicata su tavola girevole NIKKEN
Special aluminum Zero Point fixture on NIKKEN rotary table



Attrezzatura speciale con Zero Point applicata su tavola girevole HAAS
Special aluminum Zero Point fixture on HAAS rotary table



Spalla Zero Point
per centro orizzontale

Zero Point
two sides tombstone
for horizontal
machining centre



Cubo con
6 Zero Point
per lato

Zero Point
with 6 Zero Point
for each side



Cubo a reticolo con
bussolle ed helicoil
riportati + 2 piastre
Zero Point montate

Grid cube with bushings
and helicoil + 2 Zero
Point plates

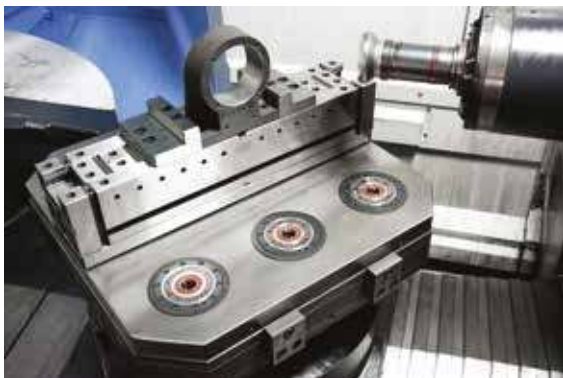

Morsa FMS montata su piastra Zero Point
FMS vises mounted on Zero Point plates

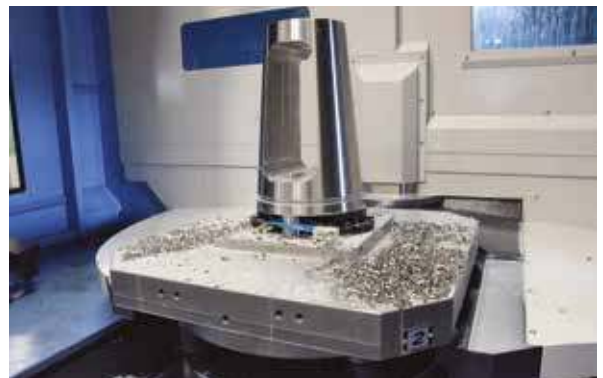

Lavorazione di particolare su piastra Zero Point
Workpieces on Zero Point base plate