

IC Independent Chuck (Hard Jaws) (200mm - 400mm)

Thru Hole Range : $\varnothing 50 \sim \varnothing 90$
Clamping Range : $\varnothing 75 \sim \varnothing 360$

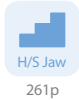
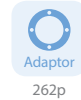

Application / Benefits

Independently jaws suitable for irregular work
Chucks 10 inches and larger have t-slots on body for added versatility

Technical features

One-piece, reversible hard jaws

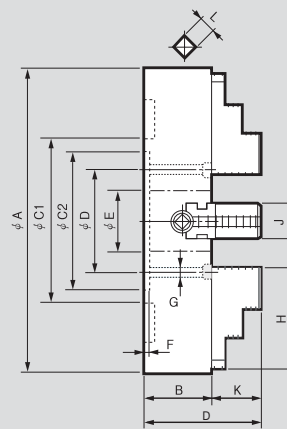
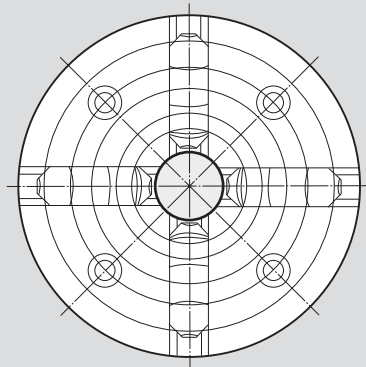

DIMENSIONS

	IC-08	IC-10	IC-12	IC-14	IC-16
A	200	250	300	350	400
B	75	80	90	90	100
C1	200	165	186	210	130
C2	175	150	170	190	210
D	155	125	140	160	180
E	50	55	65	75	90
F	6	6	6	8	8
G	M12	M12	M12	M12	M16
H	75	90	100	110	120
J	30	30	35	35	40
K	30	35	40	45	50
L	10	10	12	12	14

SPECIFICATIONS

	IC-08	IC-10	IC-12	IC-14	IC-16
Max. Static Gripping Force [kN(kgf)]	1000	1400	1600	1700	2000
Clamping Range External [ϕ mm]	75	95	125	155	190
Clamping Range Internal [ϕ mm]	185	220	265	310	360
Max. r.p.m. [min^{-1}]	1600	1600	1400	1400	1200
Weight [kg]	14.8	21	29.5	40	56.5
Moment of inertia [$\text{N} \cdot \text{m}^2(\text{kg} \cdot \text{m}^2)$]	0.3	0.6	1.4	2.9	4.5

* Specifications are subject to change without notice.

IC Independent Chuck (Hard Jaws) (450mm - 813mm)

Thru Hole Range : $\varnothing 100 \sim \varnothing 140$
Clamping Range : $\varnothing 220 \sim \varnothing 750$



Application / Benefits

Independently moving jaws suitable for irregular work
Chucks 10 inches and larger have t-slots on body for added versatility

Technical features

One-piece, reversible hard jaws

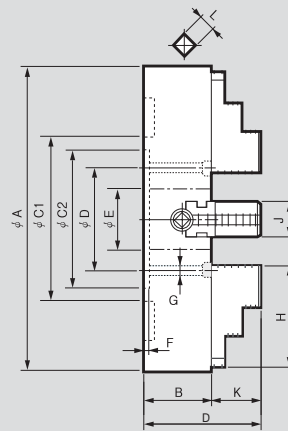
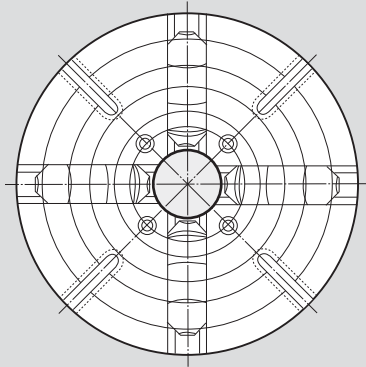

DIMENSIONS

	IC-18	IC-20	IC-24	IC-28	IC-32
A	450	500	600	710	813
B	105	110	120	120	120
C1	230	272	330	382	440
C2	230	250	300	350	400
D	200	220	260	300	350
E	100	110	120	130	140
F	8	8	10	12	12
G	M16	M16	M20	M20	M20
H	130	140	160	190	190
J	40	45	50	55	55
K	55	60	70	85	85
L	14	14	14	14	19

SPECIFICATIONS

	IC-18	IC-20	IC-24	IC-28	IC-32
Max. Static Gripping Force [kN(kgf)]	2000	2200	2300	2396	2447
Clamping Range External [ϕ mm]	220	250	320	385	485
Clamping Range Internal [ϕ mm]	405	450	550	650	750
Max. r.p.m. [min^{-1}]	1200	900	900	900	600
Weight [kg]	70	90	150	247	357
Moment of inertia [$\text{N} \cdot \text{m}^2(\text{kg} \cdot \text{m}^2)$]	7	11.8	25.3	58	103

- ※ Maximum turning speed is based upon actual measurement.
- ※ Specifications are subject to change without notice.

IC Independent Chuck (Hard Jaws) (500mm - 600mm) **MEGA BORE**

Thru Hole Range : $\varnothing 180 \sim \varnothing 275$
Clamping Range : $\varnothing 450 \sim \varnothing 550$



Application / Benefits

Durable with large bore ideal for oil-field related work such as pipe
Independently moving jaws

Technical features

Adapters enable mounting on various spindle sizes
Two-piece, reversible base and hard top jaw (also includes soft jaws)

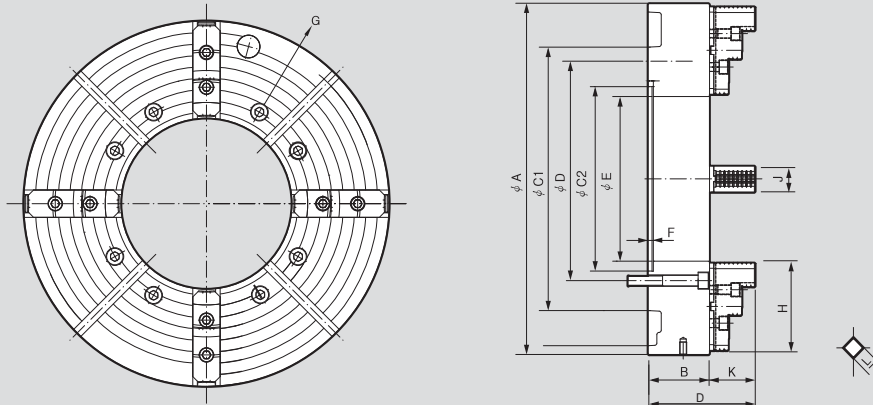

DIMENSIONS

	IC-2018	IC-2023	IC-2423	IC-2427
ΦA	500	500	600	600
B	110	110	140	140
$\Phi C2$	260	300	420	420
ΦD	230	270	463.6	463.6
ΦE	180	230	230	275
F	-	8	10	10
G	M16	M16	M24	M24
H	135	140	200	200
J	45	45	60	60
K	83.45	83.45	104.15	104.15
L	14	14	24	24

SPECIFICATIONS

	IC-2018	IC-2023	IC-2423	IC-2427
Max. Static Gripping Force [kN(kgf)]	27.4(2800)	27.4(2800)	28.5(2904)	30(3056)
Clamping Range External [ϕ mm]	460	460	550	550
Clamping Range Internal [ϕ mm]	450	450	530	550
Max. r.p.m. [min^{-1}]	800	800	800	800
Weight [kg]	180	170	350	340
Moment of inertia [$\text{N} \cdot \text{m}^2(\text{kg} \cdot \text{m}^2)$]	54.9(5.6)	51.41(5.3)	61.74(6.3)	61.74(6.3)

※ Soft & Hard jaws are basic components.
※ Specifications are subject to change without notice.

IC Independent Chuck (Hard Jaws)

(600mm - 1000mm) **MEGA BORE**

Thru Hole Range : $\varnothing 320 \sim \varnothing 560$
Clamping Range : $\varnothing 550 \sim \varnothing 1000$



Application / Benefits

Durable with large bore ideal for oil-field related work such as pipe
Independently moving jaws

Technical features

Adapters enable mounting on various spindle sizes
Two-piece, reversible base and hard top jaw (also includes soft jaws)

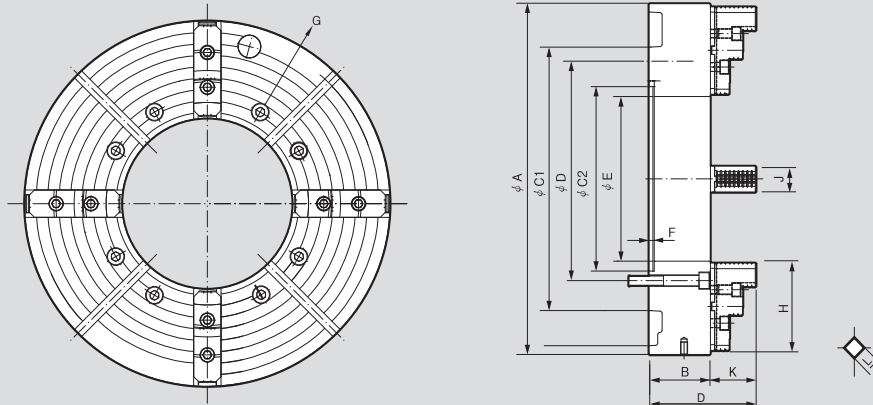

DIMENSIONS

	IC-2432	IC-3232	IC-3237	IC-4056
ΦA	600	800	800	1000
B	140	140	140	160
$\Phi C2$	420	420	420	650
ΦD	463.6	463.6	463.6	700
ΦE	320	325	375	560
F	10	12	12	10
G	M24	M24	M24	M22
H	200	200	200	200
J	60	60	60	60
K	104.15	104.15	104.15	104.15
L	24	24	24	-

SPECIFICATIONS

	IC-2432	IC-3232	IC-3237	IC-4056
Max. Static Gripping Force [kN(kgf)]	30(3056)	32.4(3300)	32.4(3300)	36(3700)
Clamping Range External [ϕ mm]	550	750	750	920
Clamping Range Internal [ϕ mm]	550	730	730	840
Max. r.p.m. [min^{-1}]	800	600	600	480
Weight [kg]	340	463	490	660
Moment of inertia [$\text{N} \cdot \text{m}^2(\text{kg} \cdot \text{m}^2)$]	61.74(6.3)	382(39)	382(39)	-

※ Soft & Hard jaws are basic components.

※ Specifications are subject to change without notice.