

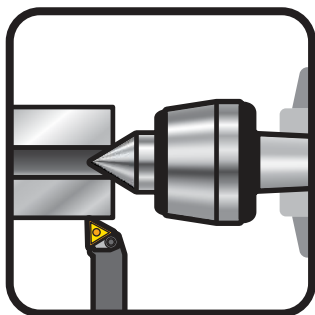

THE RIGHT LIVE CENTRE FOR EVERY APPLICATION

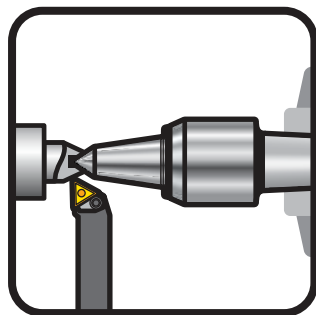

For small and large centres



For cramped work area

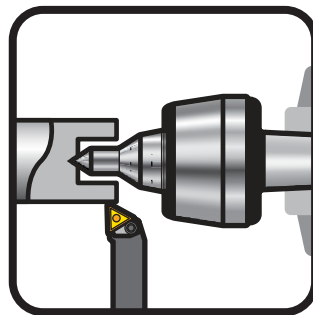

For lower-lying centres

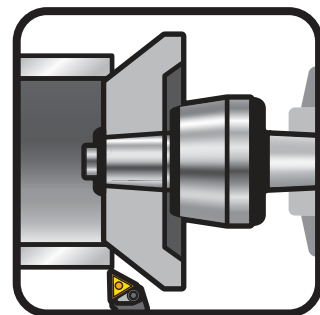

For large boreholes

LIVE CENTRES

The requirement for high cutting capacities and high working precision demands an additional support by a revolving live centre for many workpieces due to their shape and length. Thanks to their precision bearings, RÖHM live centres offer optimal force absorption and a maximum concentricity deviation of up to 0.003 mm. Thanks to the lifetime lubrication, the centre points are maintenance-free.

ADVANTAGES AT A GLANCE

- ⊕ Maximum concentricity and optimal force absorption thanks to proven precision bearings
- ⊕ Special lubrication for long service life and little required maintenance
- ⊕ Minimum interference contour thanks to slender housing shape

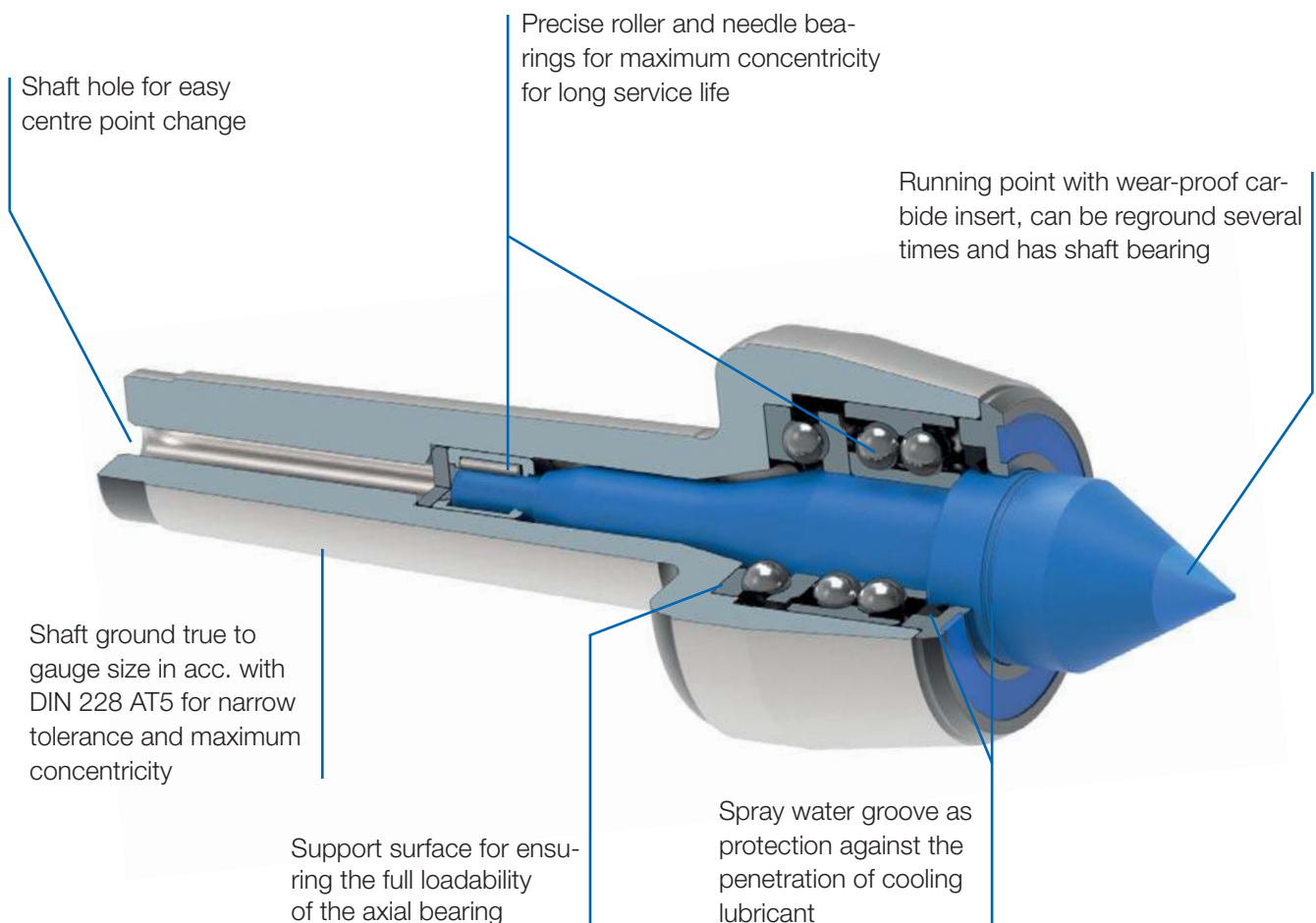

Pro - carbide insert

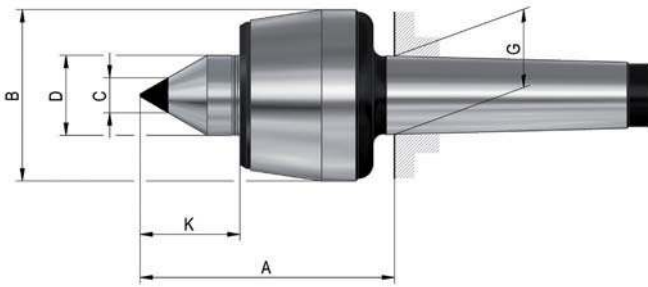

APPLICATION

For counter-clamping workpieces on turning and grinding machines.

TYPE

Centre point with wear-proof carbide insert.

CUSTOMER BENEFITS

- ⊕ Maximum service life and wear resistance thanks to carbide insert
- ⊕ High concentricity and stability thanks to 3-fold bearing
- ⊕ Maximum concentricity deviation of 0.005 mm for maximum precision

TECHNICAL FEATURES

- Body hardened and ground
- Tip angle 60°

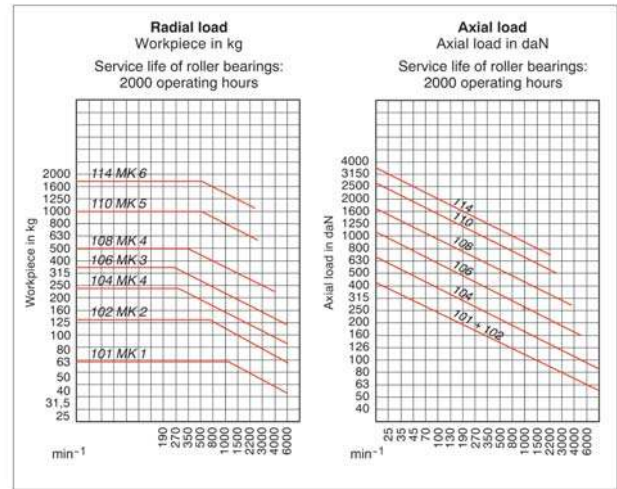

A06
HM Pro **with carbide insert**, body hardened and ground - tip angle 60°

Item no.	032140	090089	237413	093306	221016	221017
Mount MT	2	3	3	4	5	6
Size	102	104	106	108	110	114
A mm	65	70,5	79,5	102,5	129	152
B mm	43	48,5	58,5	68,5	88,5	102,5
C mm	11	11	14	14	18	18
D mm	20	22	25	32	40	50
G mm	17,78	23,825	23,825	31,267	44,399	63,348
K mm	24	27	30,5	40	49,5	57
Weight approx. g	600	900	1300	2300	4700	10000
Workpiece weight max. kg	120	240	360	500	1000	1800
Concentricity deviation max. mm	0,005	0,005	0,005	0,005	0,005	0,01
Speed max. min ⁻¹	7000	6300	5000	3800	3000	2600
Spare live centres	1241742	1241743	1241744	1241745	1241746	1241747

Pro - carbide insert

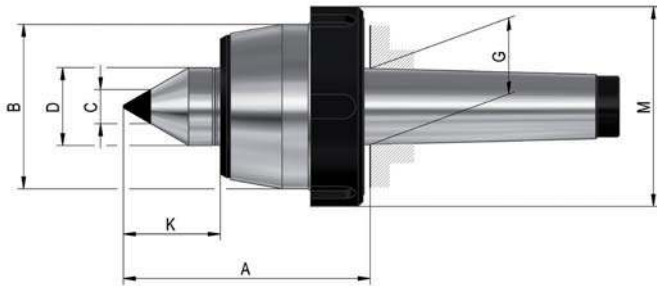

APPLICATION

For counter-clamping workpieces on turning and grinding machines.

TYPE

Centre point with wear-proof carbide insert.
With draw-off nut.

CUSTOMER BENEFITS

- ⊕ Maximum service life and wear resistance thanks to carbide insert
- ⊕ High concentricity and stability thanks to 3-fold bearing
- ⊕ Maximum concentricity deviation of 0.005 mm for maximum precision

TECHNICAL FEATURES

- Body hardened and ground
- Tip angle 60°

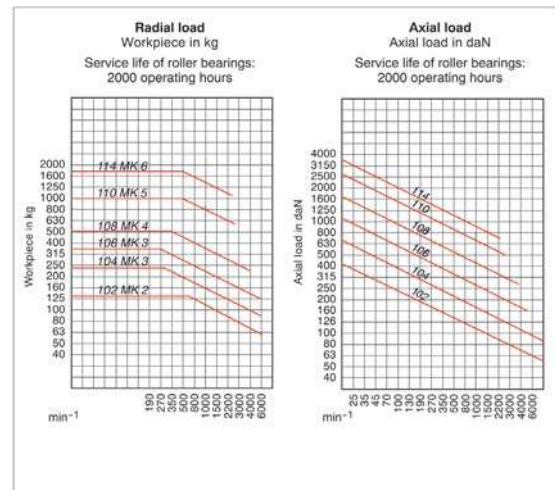

A06
HMG Pro with draw-off nut and carbide insert, body hardened and ground - tip angle 60°

Item no.	221021	221022	221023	221024	221025	221026
Mount MT	2	3	3	4	5	6
Size	102	104	106	108	110	114
A mm	65	70,5	79,5	102,5	129	152
B mm	45	50	60	70	90	105
C mm	11	11	14	14	18	18
D mm	20	22	25	32	40	50
G mm	17,78	23,825	23,825	31,265	44,399	63,348
K mm	24	27	30,5	40	49,5	57
M mm	56	62	74	82	105	120
Weight approx. g	600	1000	1400	2400	5200	10500
Workpiece weight max. kg	120	240	360	500	1000	1800
Concentricity deviation max. mm	0,005	0,005	0,005	0,005	0,005	0,01
Speed max. min ⁻¹	7000	6300	5000	3800	3000	2600
Spare live centres	1241742	1241743	1241744	1241745	1241746	1241747

Pro - standard design

Live centres

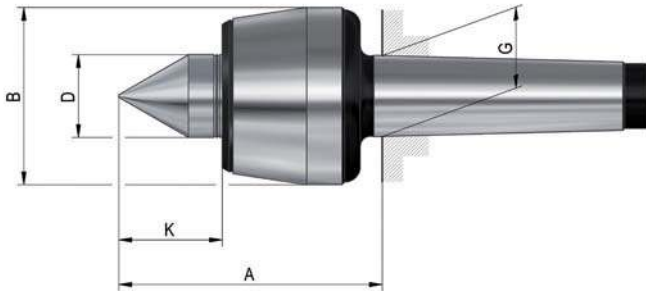

APPLICATION

For counter-clamping workpieces on turning and grinding machines.

TYPE

All-round live centre in classical design for nearly any standard clamping situation.

CUSTOMER BENEFITS

- ⊕ Proven 3-fold bearing for high axial and radial load
- ⊕ Lifetime lubrication for minimum required maintenance
- ⊕ Maximum concentricity deviation of 0.005 mm for maximum precision

TECHNICAL FEATURES-

- Body hardened and ground (MT 1 - Metr. 80)
- Tip angle 60°

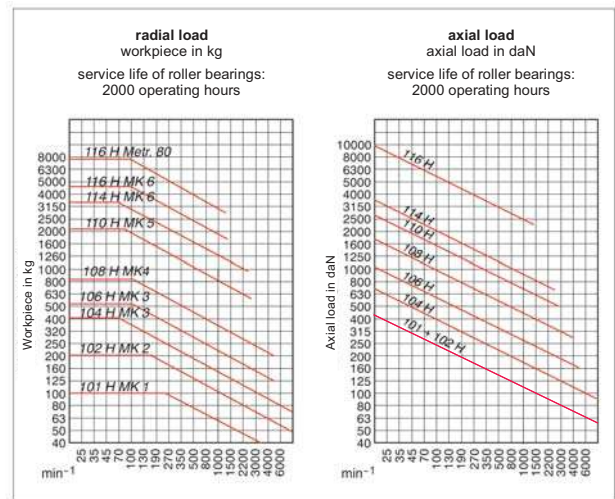

A06
H Pro, body hardened and ground - tip angle 60°

Item no.	061740 ¹⁾	043400	043115	042315	042776	042175	042843	043532	093439	093440
Mount MT	0	1	2	3	3	4	5	6	6	Metr. 80
Size	100	101	102	104	106	108	110	114	116	116
A mm	44	60,5	65	70,5	79,5	102,5	129	152	196	196
B mm	25	34,5	43	48,5	58,5	68,5	88,5	102,5	138,5	138,5
D mm	10	15	20	22	25	32	40	50	60	60
G mm	9,045	12,065	17,78	23,825	23,825	31,267	44,399	63,348	63,348	80
K mm	11	17	24	27	30,5	40	49,5	57	66	66
Weight approx. g	200	400	500	800	1300	2300	4700	10200	17800	23000
Workpiece weight max. kg	10	100	200	400	500	800	2000	3500	5000	7500
Concentricity deviation max. mm	0,01	0,005	0,005	0,005	0,005	0,005	0,005	0,008	0,01	0,015
Speed max. min ⁻¹	15000	7000	7000	6300	5000	3800	3000	2600	1500	1500
Spare live centres	1241727	1241726	1241725	1241724	1241723	1241722	1241721	1241728	1241729	1241730

1) body only ground not hardened

Pro - standard design

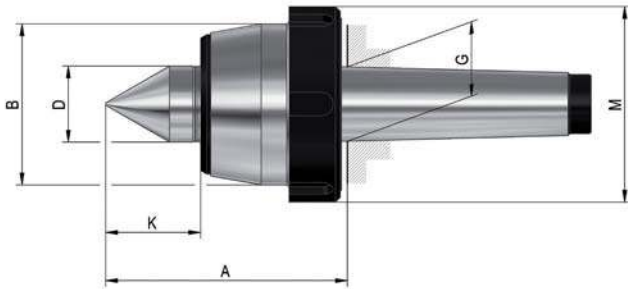

APPLICATION

For counter-clamping workpieces on turning and grinding machines.

TYPE

All-round live centre in classical design for nearly any standard clamping situation. With draw-off nut.

CUSTOMER BENEFITS

- ⊕ Proven 3-fold bearing for high axial and radial load
- ⊕ Lifetime lubrication for minimum required maintenance
- ⊕ Maximum concentricity deviation of 0.005 mm for maximum precision

TECHNICAL FEATURES

- Body hardened and ground (MT 2 - 6)
- Tip angle 60°

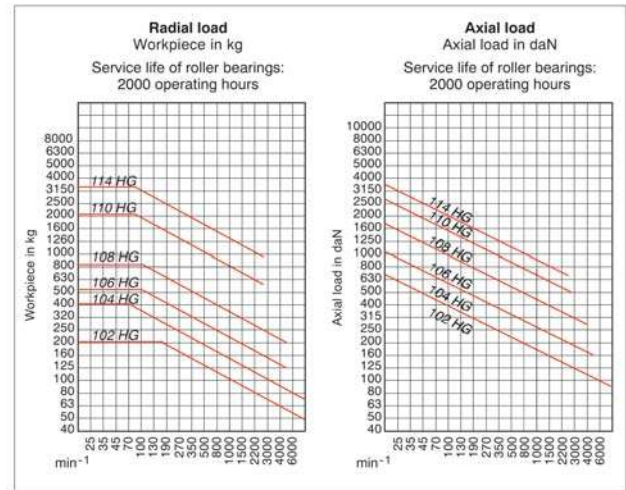

A06
HG Pro, with draw-off nut, body hardened and ground - tip angle 60°

Item no.	221018	221019	205036	207148	074390	221020
Mount MT	2	3	3	4	5	6
Size	102	104	106	108	110	114
A mm	65	70,5	79,5	102,5	129	152
B mm	45	50	60	70	90	105
D mm	20	22	25	32	40	50
G mm	17,78	23,825	23,825	31,267	44,399	63,348
K mm	24	27	30,5	40	49,5	57
M mm	56	62	74	82	105	120
Weight approx. g	600	1000	1400	2400	5200	10500
Workpiece weight max. kg	200	400	500	800	2000	3500
Concentricity deviation max. mm	0,005	0,005	0,005	0,005	0,005	0,008
Speed max. min ⁻¹	7000	6300	5000	3800	3000	2600
Spare live centres	1241725	1241724	1241723	1241722	1241721	1241728

Pro - cylindrical shank

Live centres



APPLICATION

For the counter-clamping of workpieces on turning and grinding machines using rotary chucks, collet chucks and tool take-ups.
Take-up for tool magazine / turret.

TYPE

All-round live centre with cylindrical shank.

CUSTOMER BENEFITS

- ② Proven 3-fold bearing for high axial and radial load
- ② Lifetime lubrication for minimum required maintenance
- ② Maximum concentricity deviation of 0.005 mm for maximum precision

TECHNICAL FEATURES

- Body hardened and ground
- Tip angle 60°

Note:

Live centres with cylindrical shank and clamping surface on request

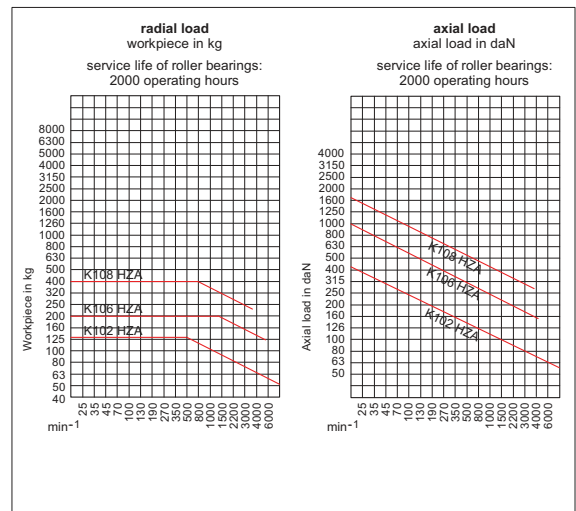
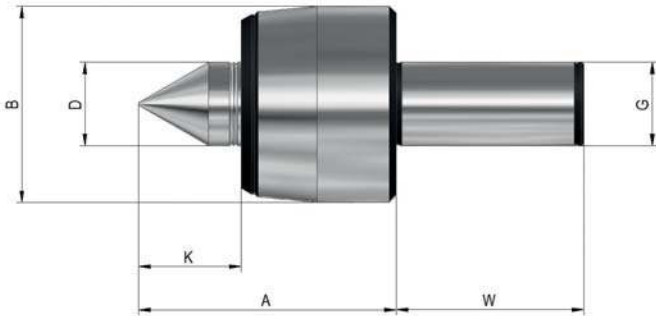

A06
HZA Pro with cylindrical shank, body hardened and ground - tip angle 60°

Item no.	1316054	1316055	1316056
Mount MT	ZA20	ZA25	ZA32
Size	102	106	108
A mm	58	76,8	93,1
B mm	43	48,5	68,5
D mm	20	25	32
G mm	20	25	32
K mm	24	30,5	40
W mm	50	56	60
Weight approx. g	414	891	1474
Workpiece weight max. kg	130	200	400
Concentricity deviation max. mm	0,005	0,005	0,005
Speed max. min ⁻¹	7000	5000	3800
Spare live centres	1241725	1241723	1241722

Pro - high precision design



APPLICATION

For counter-clamping workpieces on turning and grinding machines for highest demands.

TYPE

High precision design.

CUSTOMER BENEFITS

- ⊕ Maximum concentricity deviation of **0.003 mm** for maximum precision
- ⊕ Lifetime lubrication for minimum required maintenance
- ⊕ Proven 3-fold bearing for high axial and radial load

TECHNICAL FEATURES

- Body hardened and ground
- Tip angle 60°

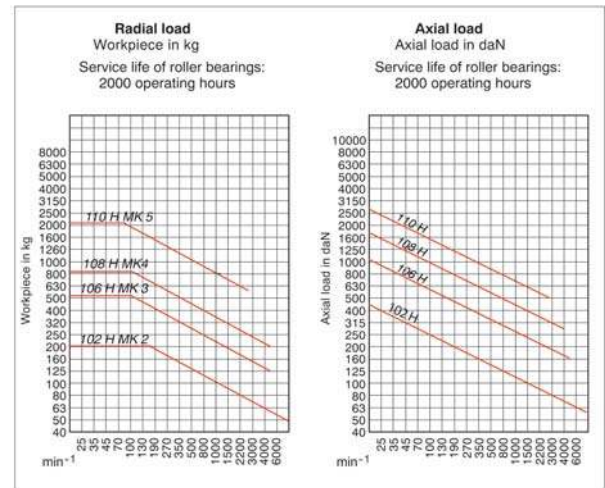
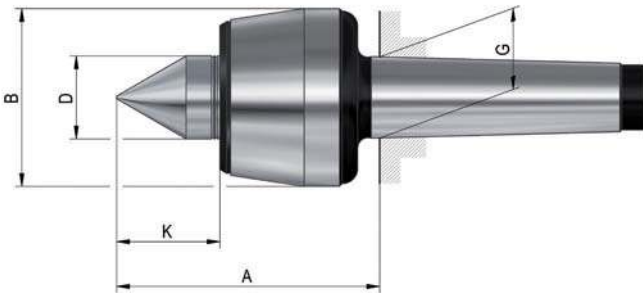

A06
HP Pro **precision version**, body hardened and ground - tip angle 60°

Item no.	082392	318227	082394	082395	1263871
Mount MT	2	3	4	5	6
Size	102	106	108	110	114
A mm	65	82	102,5	129	151,6
B mm	43	55	68,5	88,5	102,5
D mm	20	25	32	40	50
G mm	17,78	23,825	31,267	44,399	63,348
K mm	24	30,5	40	49,5	56,9
Weight approx. g	500	1300	2300	4700	8761
Workpiece weight max. kg	200	500	800	2000	3500
Concentricity deviation max. mm	0,003	0,003	0,003	0,003	0,003
Speed max. min ⁻¹	7000	5000	3800	3000	2600
Spare live centres	1241725	1243613	1241722	1241721	1241728

Pro - extended centre point



APPLICATION

For counter-clamping workpieces on turning and grinding machines. Especially suited for cramped work area between centre point and workpiece.

TYPE

All-round live centre with extended centre point.

CUSTOMER BENEFITS

- ③ Enlarged work area and better workpiece accessibility thanks to profiled centre point
- ③ High concentricity and stability thanks to 3-fold bearing
- ③ Maximum concentricity deviation of 0.005 mm for maximum precision

TECHNICAL FEATURES

- Body hardened and ground
- Tip angle 60°

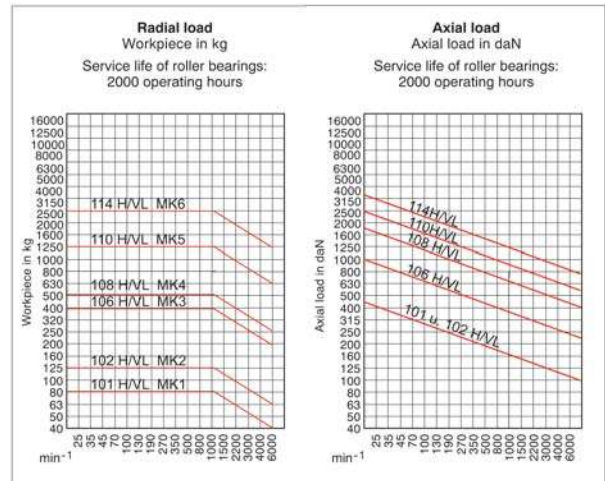
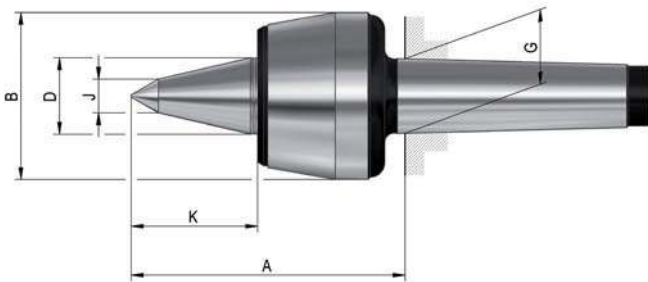

A06
HVL Pro with extended centre point, body hardened and ground - tip angle 60°

Item no.	058668	058669	058670	058671	058672	058673
Mount MT	1	2	3	4	5	6
Size	101	102	106	108	110	114
A mm	70,5	75	95,5	114,5	143,5	172,5
B mm	34,5	43	58,5	68,5	88,5	102,5
D mm	15	20	25	32	40	50
G mm	12,065	17,78	23,825	31,267	44,399	63,348
K mm	27	34	47	53	64	78
J mm	9	10	12	14	16	18
Weight approx. g	400	500	1300	2300	4800	10200
Workpiece weight max. kg	80	140	400	500	1200	2500
Concentricity deviation max. mm	0,01	0,005	0,005	0,005	0,005	0,01
Speed max. min ⁻¹	7000	7000	5000	3800	3000	2600
Spare live centres	1241731	1241732	1241733	1241734	1241735	1241736

Pro - profiled, extended centre point



APPLICATION

For counter-clamping workpieces on turning and grinding machines. Especially suited for cramped work area between centre point and workpiece as well as low-lying workpiece centres.

TYPE

All-round live centre with profiled centre point.

CUSTOMER BENEFITS

- ⊕ Enlarged work area and better workpiece accessibility thanks to profiled centre point
- ⊕ High concentricity and stability thanks to 3-fold bearing
- ⊕ Maximum concentricity deviation of 0,005 mm for maximum precision

TECHNICAL FEATURES

- Body hardened and ground
- Tip angle 60°

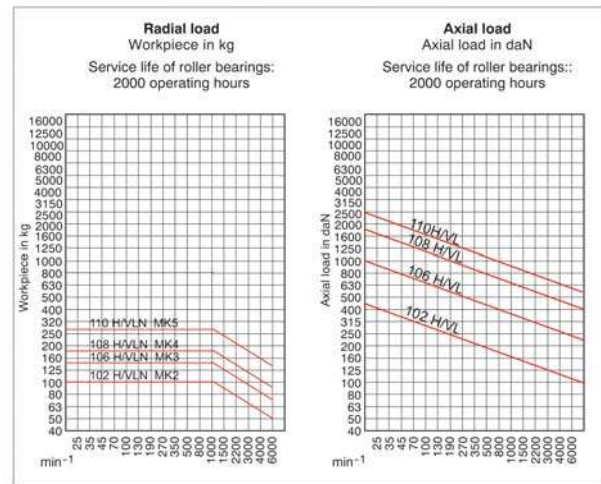
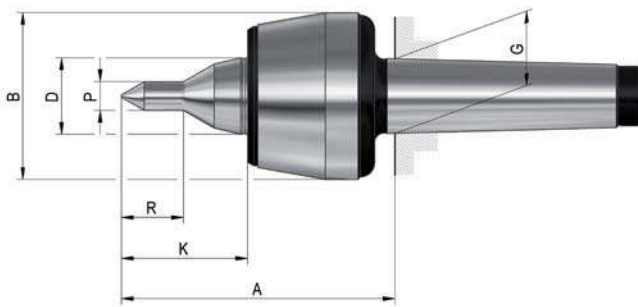

A06
HVLN Pro with profiled, extended centre point, body hardened and ground - tip angle 60°

Item no.	1241689	1241691	1241693	1241694
Mount MT	2	3	4	5
Size	102	106	108	110
A mm	75	95,5	114,5	143,5
B mm	43	58,5	68,5	88,5
D mm	20	25	32	40
G mm	17,78	23,825	31,267	44,399
K mm	34	47	53	64
P mm	8	10	12	14
R mm	16	20	26	30
Workpiece weight max. kg	100	150	180	280
Concentricity deviation max. mm	0,005	0,005	0,005	0,005
Speed max. min ⁻¹	7000	5000	3800	3000
Weight approx. g	320	460	1000	2600
Spare live centres	1243677	1243678	1243679	1243680

Orange Line

Live centres

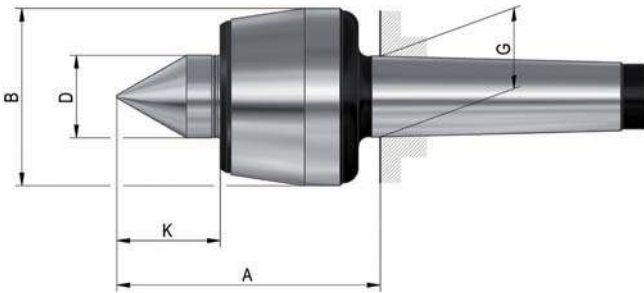

APPLICATION

For counter-clamping workpieces on turning and grinding machines.

TYPE

All-round live centre in classical design for all basic requirements for turning machining.

CUSTOMER BENEFITS

- ☉ Running tip through-hardened, and therefore can be reground as desired
- ☉ Lifetime lubrication for minimum required maintenance
- ☉ Good price/performance ratio

TECHNICAL FEATURES

- Body ground
- Tip angle 60°

Note:

For higher rotation speed at reduced lateral load

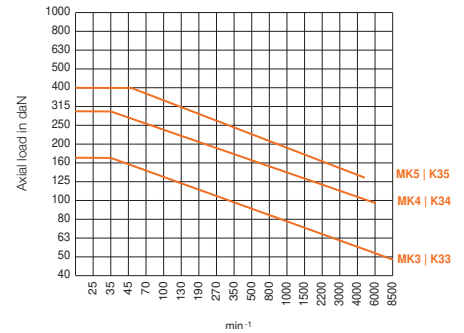
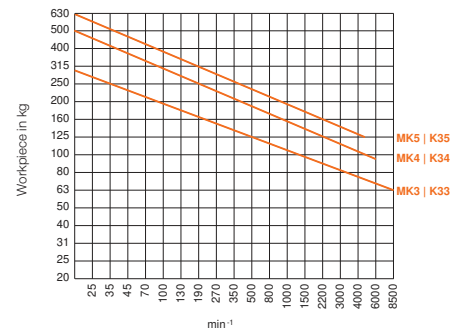

A06
Orange Line, body only ground - tip angle 60°

Item no.	1267217	1267218	1267219
Mount MT	3	4	5
Size	K33	K34	K35
A mm	82,5	101,5	128
B mm	55	68,5	88,5
D mm	25	32	40
G mm	23,825	31,267	44,399
K mm	30	40	49,5
Weight approx. g	1000	1800	4300
Workpiece weight max. kg	300	500	630
Concentricity deviation max. mm	0,005	0,005	0,005
Speed max. min ⁻¹	8500	6000	4500
Spare live centres	1243613	1241722	1241721

Heavy - standard design



APPLICATION

For counter-clamping especially heavy workpieces on turning and grinding machines.
Especially suitable for use on NC-machines.

TYPE

Universal version with extended centre point for heavy workpieces.

CUSTOMER BENEFITS

- ⊕ Robust 4-fold precision bearing for high speeds as well as high axial and radial loads
- ⊕ Reliable and safe clamping of heavy workpieces
- ⊕ Maximum concentricity deviation of 0.005 mm for maximum precision

TECHNICAL FEATURES

- Body hardened and ground
- Tip angle 60°

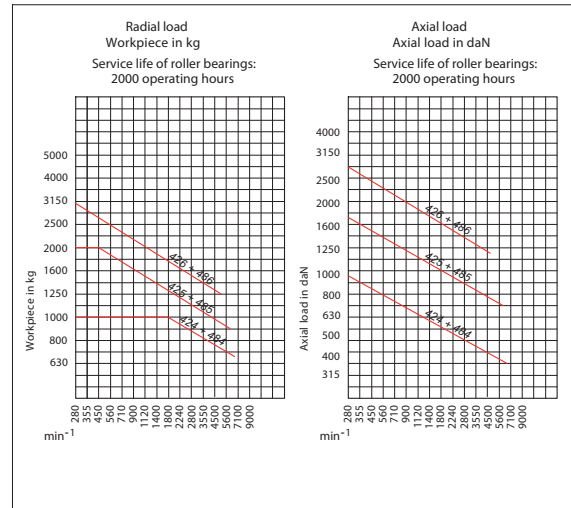
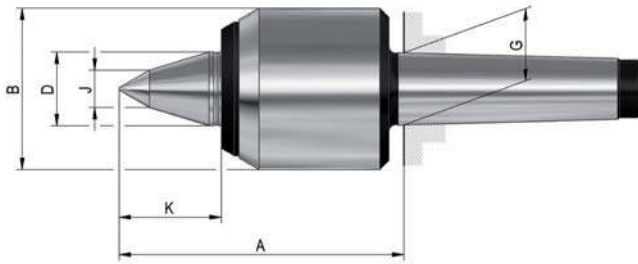

A06

Heavy especially for high load at high speeds, body hardened and ground - tip angle 60°

Item no.	303598	303599	301696
Mount MT	4	5	6
Size	424	425	426
A mm	122	150	180
B mm	70	95	120
D mm	32	42	58
G mm	31,267	44,399	63,348
J mm	16	20	26
K mm	44,5	59,5	76
Weight approx. g	2600	5500	11500
Workpiece weight max. kg	1000	2000	3000
Concentricity deviation max. mm	0,005	0,005	0,005
Speed max. min ⁻¹	7000	6000	4800
Spare live centres	1241762	1241763	1241764

Heavy - standard design



APPLICATION

For counter-clamping especially heavy workpieces on turning and grinding machines.
Especially suitable for use on NC-machines.

TYPE

Universal version with extended centre point for heavy workpieces.
With draw-off nut.

CUSTOMER BENEFITS

- ③ Robust 4-fold precision bearing for high speeds as well as high axial and radial loads
- ③ Reliable and safe clamping of heavy workpieces
- ③ Maximum concentricity deviation of 0.005 mm for maximum precision

TECHNICAL FEATURES

- Body hardened and ground
- Tip angle 60°

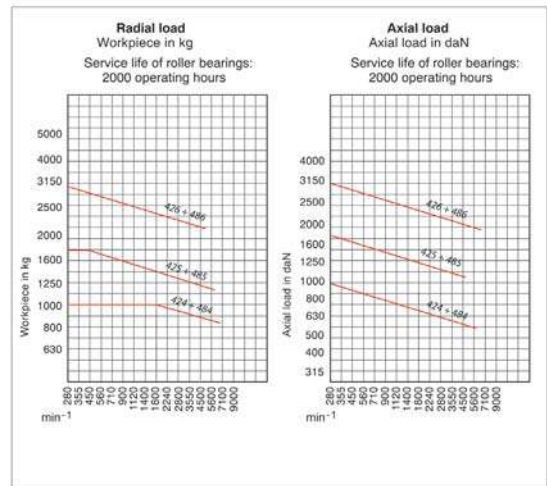
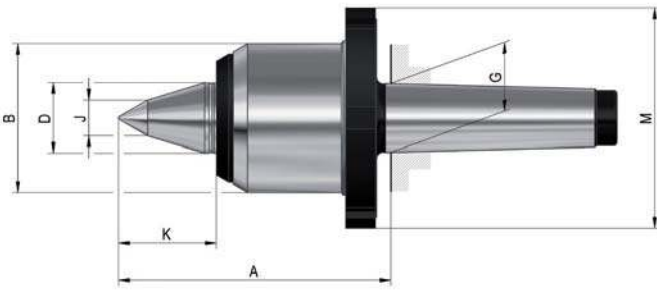

A06
Heavy with draw-off nut, especially for high load at high speeds, body hardened and ground - tip angle 60°

Item no.	304521	304522	304523
Mount MT	4	5	6
Size	484	485	486
A mm	122	150	180
B mm	70	95	120
D mm	32	42	58
G mm	31,267	44,399	63,348
J mm	16	20	26
K mm	44,5	59,5	76
M mm	100	125	155
Weight approx. g	2800	5400	12300
Workpiece weight max. kg	1000	2000	3000
Concentricity deviation max. mm	0,005	0,005	0,005
Speed max. min ⁻¹	7000	6000	4800
Spare live centres	1241762	1241763	1241764

Speed - extended centre point



APPLICATION

For counter-clamping workpieces on turning and grinding machines. Especially suitable for complex machining at high speeds.

TYPE

Special design for very high speeds with extended centre point and wear-resistant carbide insert.

CUSTOMER BENEFITS

- ⊕ Maximum rigidity for high speeds up to 12000 rpm thanks to compact design
- ⊕ Enlarged work area and better workpiece accessibility thanks to profiled centre point
- ⊕ Maximum concentricity deviation of 0.01 mm for maximum precision

TECHNICAL FEATURES

- Body hardened and ground
- Tip angle 60°

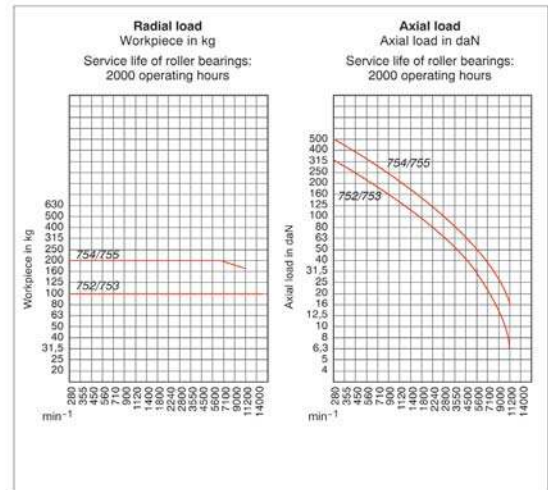
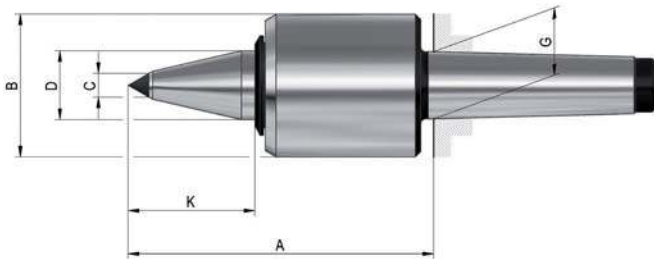

A06

Speed extended NC-centre point with carbide insert, for high speed body, hardened and ground - tip angle 60°

Item no.	772389	772390	772391	772392
Mount MT	2	3	4	5
Size	752	753	754	755
A mm	99	99	141	141
B mm	45	45	66	66
C mm	7	7	11	11
D mm	20	20	32	32
G mm	17,78	23,825	31,267	44,399
K mm	40	40	63	63
Weight approx. g	1200	1600	2600	5000
Workpiece weight max. kg	100	100	250	250
Concentricity deviation max. mm	0,01	0,01	0,01	0,01
Speed max. min ⁻¹	12000	12000	9000	9000
Spare live centres	790267	790267	790291	790291

Slim - standard design

Live centres

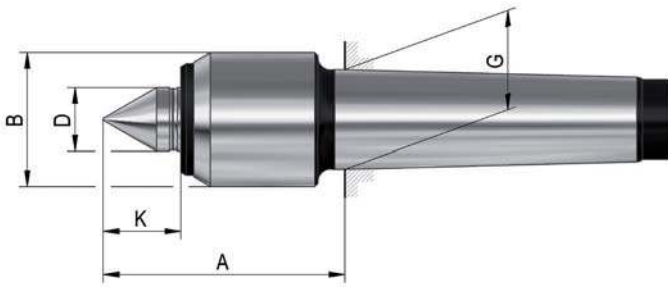

APPLICATION

For counter-clamping workpieces on turning and grinding machines. Especially suited for cramped work area between centre point and workpiece.

TYPE

Compact design with minimum casing diameter.

CUSTOMER BENEFITS

- ③ Enlarged work area and better workpiece accessibility thanks to narrow casing diameter
- ③ Maximum rigidity at high speeds thanks to compact design
- ③ Maximum concentricity deviation of 0.005 mm for maximum precision

TECHNICAL FEATURES

- Body hardened and ground
- Tip angle 60°

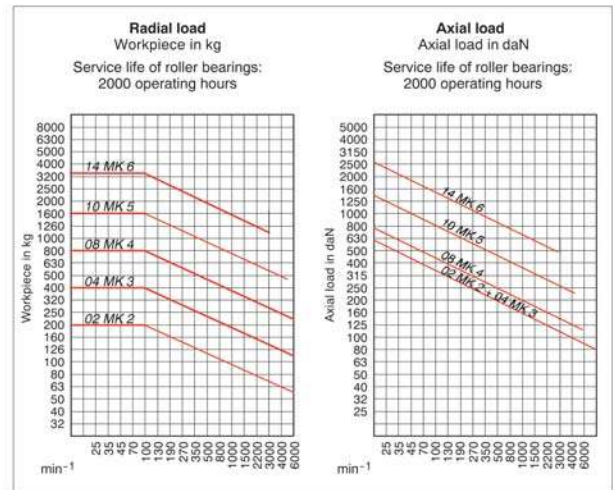

A06
Slim with small casing diameter, body hardened and ground - tip angle 60°

Item no.	005336	005429	005469	005490	005547
Mount MT	2	3	4	5	6
Size	02	04	08	10	14
A mm	62	62	75,5	106	143
B mm	32	34	42	58	80
D mm	15	15	20	30	42
G mm	17,78	23,825	31,267	44,399	63,348
K mm	19,5	19,5	24,5	37	49,5
Weight approx. g	300	400	1000	2600	7100
Workpiece weight max. kg	200	400	800	1600	3500
Concentricity deviation max. mm	0,005	0,005	0,005	0,01	0,02
Speed max. min ⁻¹	7000	7000	6300	4300	3000
Spare live centres	1241748	1241749	1241750	1241751	1241752

Slim - extended centre point

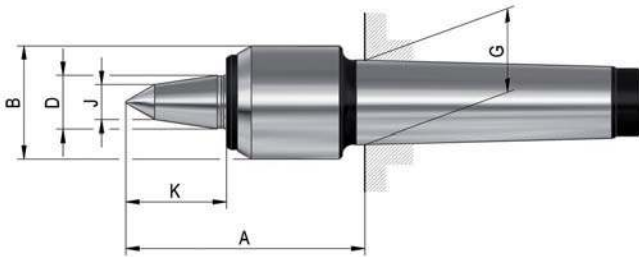

APPLICATION

For counter-clamping workpieces on turning and grinding machines. Especially suited for cramped work area between centre point and workpiece as well as low-lying workpiece centres.

TYPE

Compact design with minimum casing diameter. With extended centre point.

CUSTOMER BENEFITS

- ③ Enlarged work area and better workpiece accessibility thanks to narrow casing diameter and extended centre point
- ③ Maximum rigidity at high speeds thanks to compact design
- ③ Maximum concentricity deviation of 0.008 mm for maximum precision

TECHNICAL FEATURES

- Body hardened and ground
- Tip angle 60°

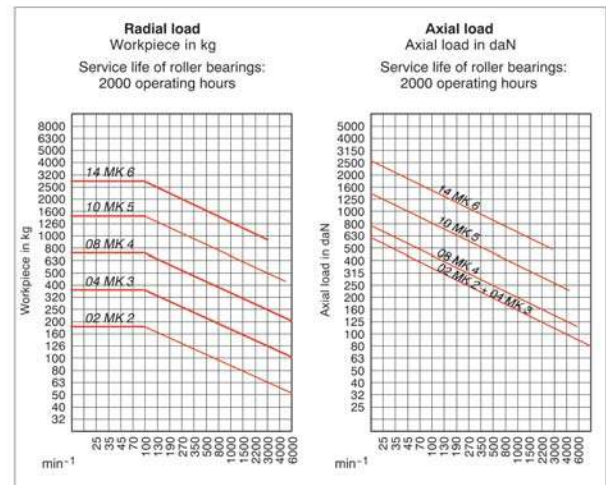

A06

Slim with small casing diameter and extended centre point, body hardened and ground - tip angle 60°

Item no.	362080	362081	362082	362083	362084
Mount MT	2	3	4	5	6
Size	02	04	08	10	14
A mm	73	74	88,5	119	164
B mm	32	34	42	58	80
D mm	15	15	20	30	42
G mm	17,78	23,825	31,267	44,399	63,348
K mm	29,5	32	37,5	51,5	70,5
J mm	10	11	13	14	18
Weight approx. g	320	460	1000	2600	7100
Workpiece weight max. kg	170	340	700	1400	3000
Concentricity deviation max. mm	0,008	0,008	0,008	0,01	0,02
Speed max. min ⁻¹	7000	7000	6300	4300	3000
Spare live centres	1241753	1241754	1241755	1241756	1241757

Slim - profiled, extended centre point

Live centres



APPLICATION

For counter-clamping workpieces on turning and grinding machines. Especially suited for cramped work area between centre point and workpiece.

TYPE

Compact design with minimum casing diameter. With extended and profiled centre point.

CUSTOMER BENEFITS

- ③ Enlarged work area and better workpiece accessibility thanks to narrow casing diameter and extended and profiled centre point
- ③ Maximum rigidity at high speeds thanks to compact design
- ③ Maximum concentricity deviation of 0.008 mm for maximum precision

TECHNICAL FEATURES

- Body hardened and ground
- Tip angle 60°

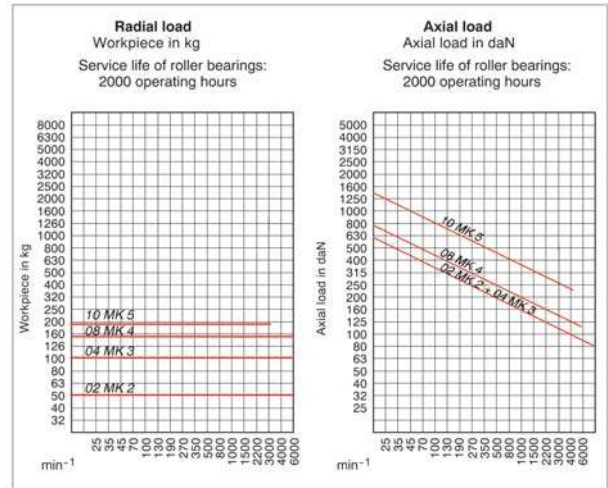
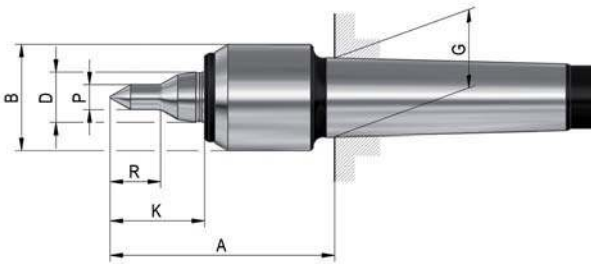

A06
Slim with small casing diameter and profiled and extended centre point, body hardened and ground - tip angle 60°

Item no.	1241695	1243505	1243507	1243509
Mount MT	2	3	4	5
Size	02	04	08	10
A mm	73	74	88,5	119
B mm	32	34	42	58
D mm	15	15	20	30
G mm	17,78	23,825	31,267	44,399
K mm	29,5	32	37,5	51,5
P mm	6	8	10	12
R mm	12	16	20	26
Workpiece weight max. kg	50	100	150	180
Concentricity deviation max. mm	0,008	0,008	0,008	0,01
Speed max. min ⁻¹	7000	7000	6300	4300
Weight approx. g	320	460	1000	2600
Spare live centres	1241758	1241759	1241760	1241761

Control - standard design



APPLICATION

For counter-clamping workpieces on turning and grinding machines. Optimally suited as counter-centre for face drivers.

TYPE

With pressure display and length compensation.

CUSTOMER BENEFITS

- ⊕ Fast adjustment and check of axial load by means of pressure display
- ⊕ Resilient centre point for safe, deformation-free workpiece clamping
- ⊕ Maximum concentricity deviation of 0.01 mm for maximum precision

TECHNICAL FEATURES

- Body hardened and ground
- Tip angle 60°

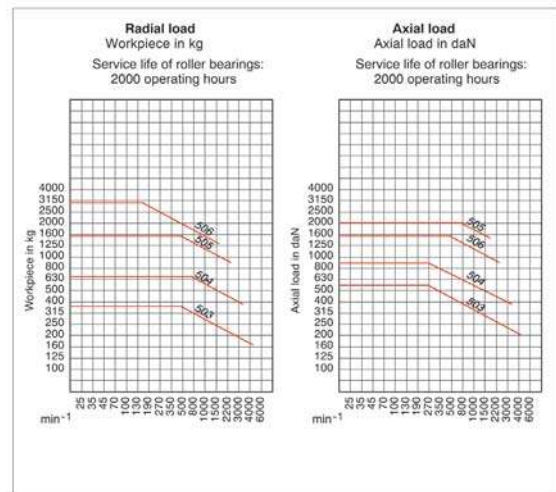
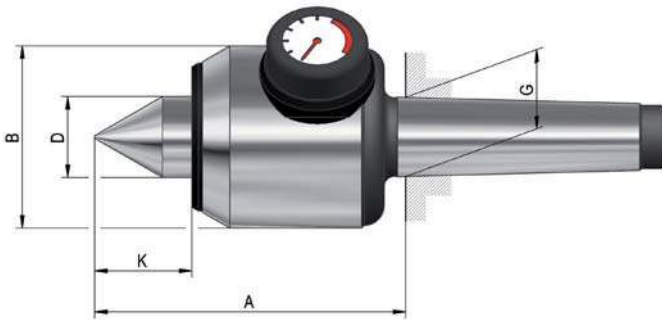

A06

AC Control with pressure display and length compensation, as counter-centre for face drivers, body hardened and ground - tip angle 60°

Item no.	060798	060874	060906	060915
Mount MT	3	4	5	6
Size	503	504	505	506
A mm	105	123,5	160,5	202
B mm	64	72	95	120
D mm	25	32	40	52
G mm	23,825	31,267	44,399	63,348
K mm	31	38,5	49	59
Weight approx. g	2100	3500	8300	17000
Spring way max. mm ¹⁾	1,6	2	1,8	2,7
Axial load max. N	5500	9000	15000	20000
Workpiece weight max. kg	400	800	1600	3200
Concentricity deviation max. mm	0,01	0,01	0,01	0,015
Speed max. min ⁻¹	4000	3500	2500	1800
Spare live centres	009192	009205	009325	009413

¹⁾ at max. axial load

Control - extended centre point

Live centres



APPLICATION

For counter-clamping workpieces on turning and grinding machines. Especially suited as counter-centre for face drivers as well as for cramped work area between centre point and workpiece.

TYPE

With pressure display, length compensation and extended live centre.

CUSTOMER BENEFITS

- ② Fast adjustment and check of axial load by means of pressure display
- ② Enlarged work area and better workpiece accessibility thanks to extended centre point
- ② Resilient live centre for safe, deformation-free workpiece clamping
- ② Maximum concentricity deviation of 0.01 mm for maximum precision

TECHNICAL FEATURES

- Body hardened and ground
- Tip angle 60°

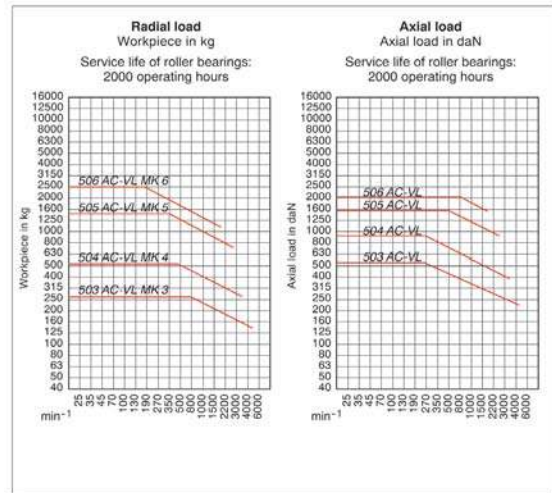
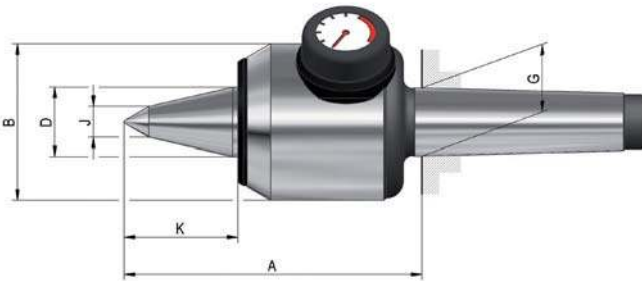

A06
AC-VL Control with **pressure display, length compensation and extended centre point**, as counter-centre for face drivers, body hardened and ground - tip angle 60°

Item no.	079920	079921	079922	079923
Mount MT	3	4	5	6
Size	503	504	505	506
A mm	120	137,5	177,5	223
B mm	64	72	95	120
D mm	25	32	40	52
G mm	23,825	31,267	44,399	63,348
K mm	45,5	52,5	66	80
J mm	11	14	15	24
Weight approx. g	2200	3600	8400	17500
Spring way max. mm ¹⁾	1,6	2	1,8	2,7
Axial load max. N	5500	9000	15000	20000
Workpiece weight max. kg	260	550	1100	2500
Concentricity deviation max. mm	0,01	0,01	0,01	0,015
Speed max. min ⁻¹	4000	3500	2500	1800
Spare live centres	079924	079925	079926	079927

¹⁾ at max. axial load

Flex - interchangeable inserts



APPLICATION

For counter-clamping workpieces on turning and grinding machines.

TYPE

With interchangeable inserts made of wear-resistant tool steel for maximum flexibility.

CUSTOMER BENEFITS

- ② Wide range of applications thanks to interchangeable inserts
- ② Quick change of interchangeable inserts

TECHNICAL FEATURES

- Body hardened and ground
- Inserts through-hardened and ground

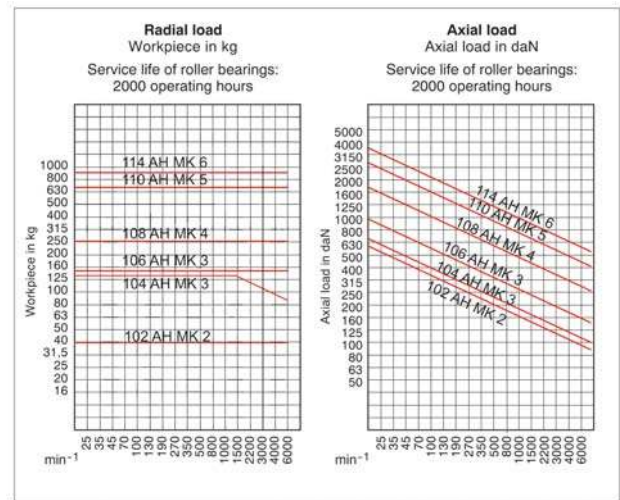
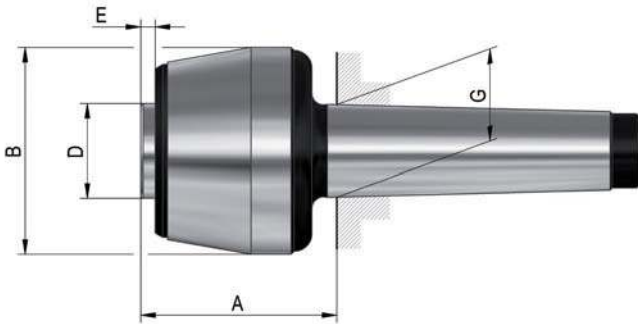

A06

Flex for **interchangeable inserts**, body hardened and ground

Item no.	061030	061031	061032	061038	061039	061040
Mount MT	2	3	3	4	5	6
Size	102	104	106	108	110	114
A mm	45	48	55	67	85	101
B mm	43	48,5	58,5	68,5	88,5	102,5
D mm	20	22	25	32	40	50
E mm	4	4	5,5	5	6	6
G mm	17,78	23,825	23,825	31,267	44,399	63,348
Concentricity deviation max. mm	0,01	0,01	0,01	0,01	0,01	0,015
Speed max. min ⁻¹	7000	6300	5000	3800	3000	2600
Workpiece weight max. kg	40	130	150	250	650	900
Weight without inserts	440	750	1100	1900	4400	8600
Weight g	900	1700	2200	3700	8000	-
Spare live spindle	009836	009838	009843	009870	009872	009874

Interchangeable inserts

A06
Interchangeable inserts 60°

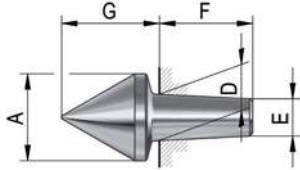

Item no.	Size	A mm	D mm	E mm	F mm	G mm
070725	102	16	7	5,2	18	20
070728	104	20	12	9,6	24	24
070731	106	24	12	9,6	24	27,5
070734	108	28	15	12	30	31,5
070737	110	38	22	18,5	35	43
070740	114	50	28	24	40	54

A06
Interchangeable inserts 90°

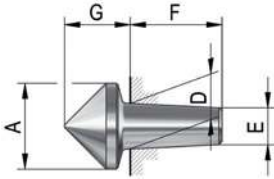

Item no.	Size	A mm	D mm	E mm	F mm	G mm
070727	102	16	7	5,2	18	14,5
070730	104	20	12	9,6	24	16,5
070733	106	24	12	9,6	24	19
070736	108	28	15	12	30	21,5
070739	110	38	22	18,5	35	29
070742	114	50	28	24	40	36

A06
Interchangeable inserts 60°VL

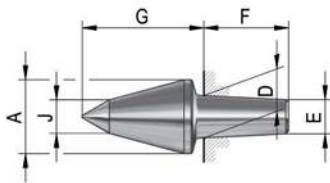

Item no.	Size	A mm	D mm	E mm	F mm	G mm	J mm
070719	102	14	7	5,2	18	25	6
070720	104; 106	18	12	9,6	24	30	8
070721	108	26	15	12	30	43	12
070722	110	32	22	18,5	35	55	13
070723	114	42	28	24	40	70	18,5

A06
Interchangeable inserts for tubular workpieces 60°

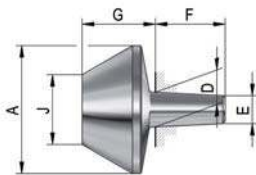

Item no.	Size	A mm	D mm	E mm	F mm	G mm	J mm
070700	102	25	7	5,2	18	21	10
070701	104	35	12	9,6	24	26	15
070702	106	45	12	9,6	24	27	25
070703	108	55	15	12	30	31,5	30
070704	110	70	22	18,5	35	39	40
070705	114	100	28	24	40	52	55

A06
Interchangeable inserts A for centreless workpieces 60°

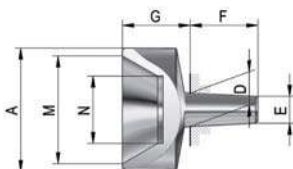

Item no.	Size	A mm	D mm	E mm	F mm	G mm	M mm	N mm
070707	102	25	7	5,2	18	18	20	10
070708	104	35	12	9,6	24	24	30	15
070709	106	45	12	9,6	24	25	40	25
070710	108	55	15	12	30	30	48	30
070711	110	70	22	18,5	35	39	63	40
070712	114	100	28	24	40	52	90	55

Interchangeable inserts

A06
Interchangeable inserts **B** for centreless workpieces 60°

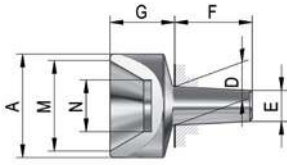

Item no.	Size	A mm	D mm	E mm	F mm	G mm	M mm	N mm
228620	102	16	7	5,2	18	12	12	6
228621	106	22	12	9,6	24	16	18	10
228622	108	40	15	12	30	25	35	20
308632	110	52	22	18,5	35	30	45	30

A06
Extractor



Item no.	For size
061707	102
061708	104/106/108
061709	110/114

A14
Mounting sleeve for clamping the face driver in the rotary chuck

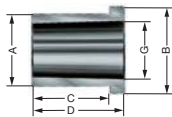

Item no.	MT inside	A mm	B mm	C mm	D mm	G mm
085033	3	32	39	32	40	23,825
085034	4	40	47	42	50	31,267
085035	5	55	62	52	60	44,399
085036	6	75	83	62	70	63,448

Live centres

Flex - interchangeable inserts

Live centres



APPLICATION

For counter-clamping workpieces on turning and grinding machines.

TYPE

With interchangeable inserts made of wear-resistant tool steel for maximum flexibility.

CUSTOMER BENEFITS

- ☺ Wide range of applications thanks to interchangeable inserts
- ☺ Quick change of interchangeable inserts

TECHNICAL FEATURES

- Body hardened and ground
- Inserts through-hardened and ground

Included in scope of delivery:

- 1 basic body for interchangeable inserts
- 1 extractor
- 1 insert 60°, 90°, 60°VL
- 1 insert or tubular workpieces 60°
- 2 inserts for centreless workpieces 60°
- Inclusive wooden case

A06

Complete with all inserts in a sturdy wooden case

Item no.	061702	061703	061704	061705	061706
Mount MT	2	3	3	4	5
Size	102	104	106	108	110
Workpiece weight max. kg	40	130	150	250	650
Weight g	900	1700	2200	3700	8000