

LM CENTER

▶ LM-A TYPE

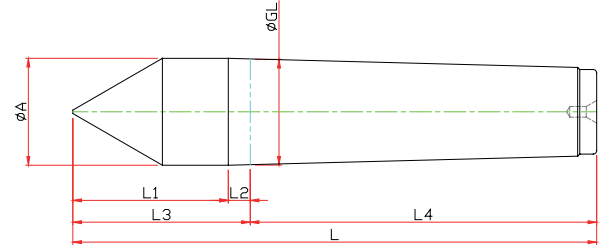

Model	Order Number	Morse Taper	Dimension							Run Out
			GL	A	L1	L2	L3	L4	L	
LM-1A	110001	NO.1	12.065	12.2	25	3.5	28.5	53.5	82	0.003
LM-2A	110002	NO.2	17.780	18	31	5	36	64	100	0.003
LM-3A	110003	NO.3	23.825	24	39	5	44	81	125	0.003
LM-4A	110004	NO.4	31.267	31.6	46	6.5	52.5	102.5	155	0.003
LM-5A	110005	NO.5	44.399	44.7	64	6.5	70.5	129.5	200	0.003
LM-6A	110006	NO.6	63.348	63.8	80	8	88	182	270	0.005
LM-7A	110007	NO.7	83.058	83.6	105	10	115	250	365	0.005

▶ LM-C TYPE

※ Carbide Type

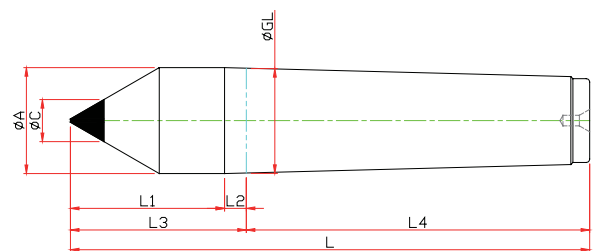

Model	Order Number	Morse Taper	Dimension								Run Out
			GL	A	L1	L2	L3	L4	C	L	
LM-1C	110101	NO.1	12.065	12.2	25	3.5	28.5	53.5	7	82	0.003
LM-2C	110102	NO.2	17.780	18	31	5	36	64	7	100	0.003
LM-3C	110103	NO.3	23.825	24	39	5	44	81	10	125	0.003
LM-4C	110104	NO.4	31.267	31.6	46	6.5	52.5	102.5	14	155	0.003
LM-5C	110105	NO.5	44.399	44.7	64	6.5	70.5	129.5	18	200	0.003
LM-6C	110106	NO.6	63.348	63.8	80	8	88	182	25	270	0.005
LM-7C	110107	NO.7	83.058	83.6	105	10	115	250	30	365	0.005

LM CENTER

▶ LM-AN TYPE

※ Nut Type

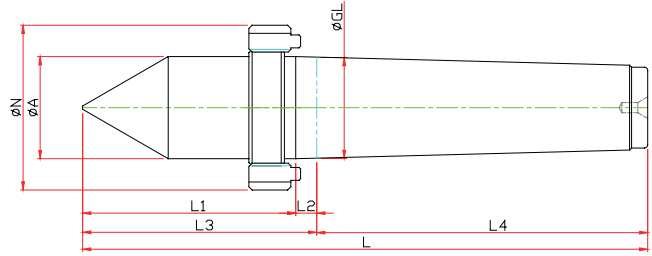

Model	Order Number	Morse Taper	Dimension								Run Out
			GL	A	L1	L2	L3	L4	N	L	
LM-1AN	110011	NO.1	12.065	12.2	31.5	5	36.5	53.5	M16	90	0.003
LM-2AN	110012	NO.2	17.780	18	41.5	6.5	48	64	M22	112	0.003
LM-3AN	110013	NO.3	23.825	24	49.5	7.5	57	81	M27	138	0.003
LM-4AN	110014	NO.4	31.267	31.6	62.5	10	72.5	102.5	M36	175	0.003
LM-5AN	110015	NO.5	44.399	44.7	77	11	88	129.6	M48	217.5	0.003
LM-6AN	110016	NO.6	63.348	63.8	96.5	11.5	108	182	M68	290	0.005
LM-7AN	110017	NO.7	83.058	83.6	108.5	11.5	120	250	M90	370	0.005

▶ LM-CN TYPE

※ Carbide, Nut Type

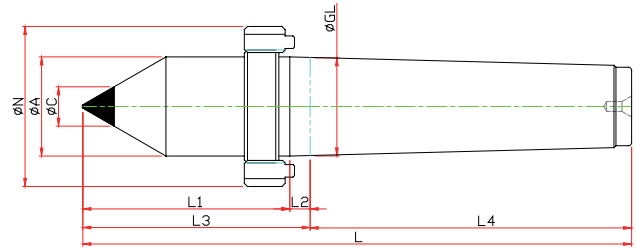

Model	Order Number	Morse Taper	Dimension									Run Out
			GL	A	L1	L2	L3	L4	C	N	L	
LM-1CN	110111	NO.1	12.065	12	31.5	5	36.5	53.5	7	M16	90	0.003
LM-2CN	110112	NO.2	17.780	18	41.5	6.5	48	64	7	M22	112	0.003
LM-3CN	110113	NO.3	23.825	24	49.5	7.5	57	81	10	M27	138	0.003
LM-4CN	110114	NO.4	31.267	32	62.5	10	72.5	102.5	14	M36	175	0.003
LM-5CN	110115	NO.5	44.399	45	77	11	88	129.5	18	M48	217.5	0.003
LM-6CN	110116	NO.6	63.348	64	96.5	11.5	108	182	18	M68	290	0.005

▶ LM SPECIAL

※ Customized-special production for user's condition



LM-H CENTER

▶ LM-H TYPE

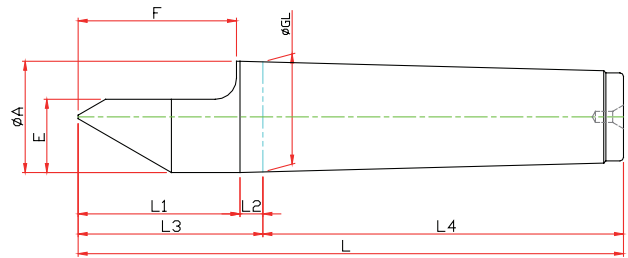

Model	Order Number	Morse Taper	Dimension									Run Out
			GL	A	L1	L2	L3	L4	E	F	L	
LM-1H	110001	NO.1	12,065	12,2	25	3,5	28,5	53,5	7,6	22	82	0,003
LM-2H	110002	NO.2	17,780	18	31	5	36	64	11	30	100	0,003
LM-3H	110003	NO.3	23,825	24	39	5	44	81	15	38	125	0,003
LM-4H	110004	NO.4	31,267	31,6	46	6,5	52,5	102,5	21	45	155	0,003
LM-5H	110005	NO.5	44,399	44,7	64	6,5	70,5	129,5	27,4	63	200	0,003
LM-6H	110006	NO.6	63,348	63,8	80	8	88	182	38,9	79	270	0,005

▶ LM-HC TYPE

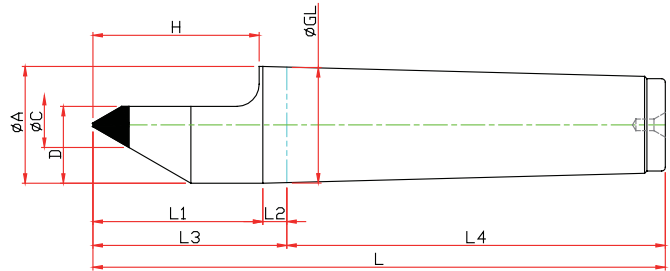

Model	Order Number	Morse Taper	Dimension										Run Out
			GL	A	L1	L2	L3	L4	C	D	H	L	
LM-1HC	210101	NO.1	12,065	12,2	25	3,5	28,5	53,5	7	7,6	22	82	0,003
LM-2HC	210102	NO.2	17,780	18	31	5	36	64	7	11	30	100	0,003
LM-3HC	210103	NO.3	23,825	24	39	5	44	81	10	15	38	125	0,003
LM-4HC	210104	NO.4	31,267	31,6	46	6,5	52,5	102,5	14	21	45	125	0,003
LM-5HC	210105	NO.5	44,399	44,7	64	6,5	70,5	129,5	18	27,4	63	200	0,003
LM-6HC	210106	NO.6	63,348	63,8	80	8	88	182	25	38,9	79	270	0,005

LM-H CENTER

▶ LM-HN TYPE

※ Nut Type

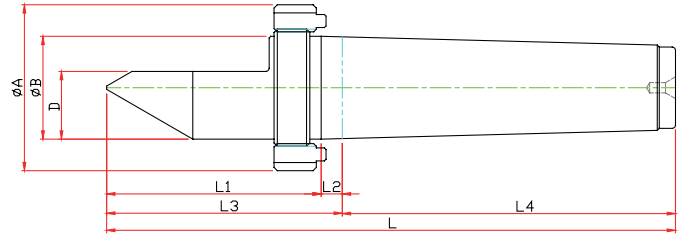

Model	Order Number	Morse Taper	Dimension										Run Out
			GL	A	L1	L2	L3	L4	D	E	N	L	
LM-1HN	210011	NO.1	12,065	12	31.5	5	36.5	53.5	7.6	22	M16	90	0.003
LM-2HN	210012	NO.2	17,780	18	41.5	6.5	48	64	11	30	M22	112	0.003
LM-3HN	210013	NO.3	23,825	24	49.5	7.5	57	81	15	38	M27	138	0.003
LM-4HN	210014	NO.4	31,267	32	62.5	10	72.5	102.5	21	50	M36	175	0.003
LM-5HN	210015	NO.5	44,399	45	77	11	88	129.5	29.4	63	M48	217.5	0.003
LM-6HN	210016	NO.6	63,348	64	96.5	11.5	108	182	42	79	M68	290	0.005

▶ LM-HCN TYPE

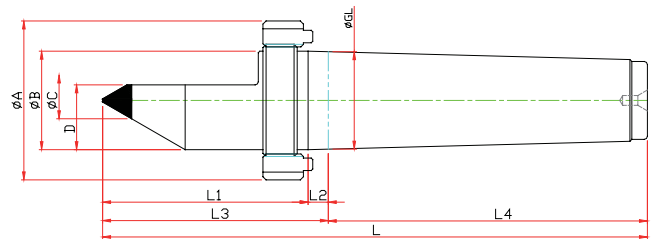

Model	Order Number	Morse Taper	Dimension											Run Out
			GL	A	L1	L2	L3	L4	C	D	E	N	L	
LM-1HCN	210111	NO.1	12,065	12	31.5	5	36.5	53.5	7	7.6	22	M16	90	0.003
LM-2HCN	210112	NO.2	17,780	18	41.5	6.5	48	64	7	11	30	M22	112	0.003
LM-3HCN	210113	NO.3	23,825	24	49.5	7.5	57	81	10	15	38	M27	138	0.003
LM-4HCN	210114	NO.4	31,267	32	62.5	10	72.5	102.5	14	21	50	M36	175	0.003
LM-5HCN	210115	NO.5	44,399	45	77	11	88	129.5	18	29.4	63	M48	217.5	0.003
LM-6HCN	210116	NO.6	63,348	64	96.5	11.5	108	182	18	42	79	M68	290	0.005

▶ LM-H SPECIAL

※ Customized-special production for user's condition



LM-FN TYPE

▶ LM-FN TYPE

※ Spanner Type

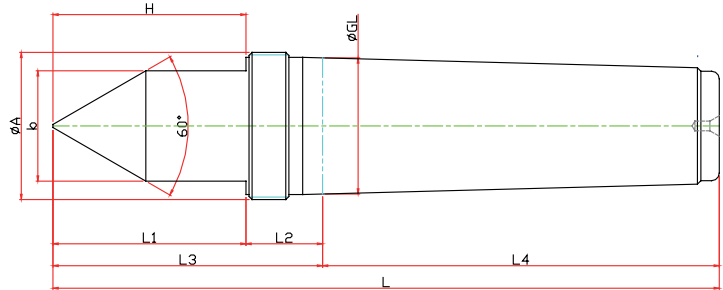

Model	Order Number	Morse Taper	Dimension										Run Out
			GL	A	b	L1	L2	L3	L4	E	L		
LM-1FN	120011	NO.1	12.065	12.2	10	25	3.5	28.5	53.5	22	82	0.003	
LM-2FN	120012	NO.2	17.780	18	14	31	5	36	64	30	100	0.003	
LM-3FN	120013	NO.3	23.825	24	19	39	5	44	81	38	125	0.003	
LM-4FN	120014	NO.4	31.267	31.6	27	46	6.5	52.5	102.5	50	155	0.003	
LM-5FN	120015	NO.5	44.399	44.7	36	64	6.5	70.5	129.5	53	200	0.003	

▶ LM-#80 TYPE

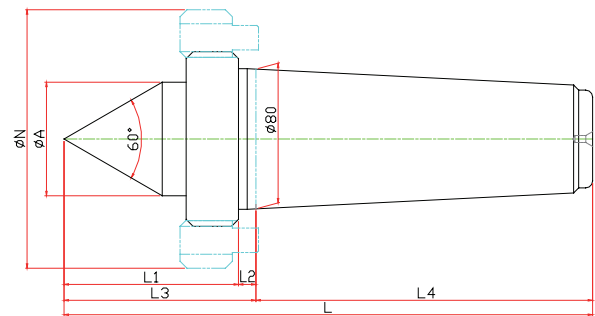

Model	Order Number	Morse Taper	Dimension										Run Out
			GL	A	b	L1	L2	L3	L4	E	L		
#80-60	260010	1/10 TAPER	80	65	148	70	30	10	110	193	303	0.005	
#80-75	275010	1/10 TAPER	80	65	148	70	30	10	110	193	303	0.005	