

DURO-TA - sealed design

Key bar chucks
DURO-TA



APPLICATION

Specially for grinding machines.
Optimized for extremely high clamping forces, maximum concentricity, as well as reliable long-term repeatability.

TYPE

Key bar chuck with quick-action jaw change system.
Guaranteed maximum jaw precision as far as these are only used on the same chuck, and base and top jaws are kept screwed on for recurring work.

CUSTOMER BENEFITS

- ③ Maximum clamping force thanks to key bar system
- ③ With cover for protection against dust on the face
- ③ Very high jaw-change repeatability

TECHNICAL FEATURES

- With jaw safeguard
- Chuck body completely surface-hardened
- Visual marking for quick jaw adjustment
- External shape incl. splash-water edge
- Fastening options for strongly stressed sliding surfaces
- Incl. safety key
- High corrosion protection

A08
Cylindrical centre mount

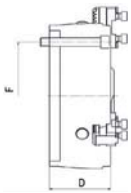

Size	Inch	With base jaws	With inside and outside jaw	D mm	Speed max. min ⁻¹	Max. Torque Nm	Max. total clamping force kN
160	6 1/4	439606	439605	63	5400	120	73
200	8	439608	439607	81	4600	155	114
250	10	439610	439609	92	4200	190	185

Further sizes and mountings available on request

Jaws DURO-TA

A28

Outside jaw DB, set, inward stepped jaw, hardened



Item no.	Chuck Size	Contents of delivery	Jaw width
329041	160	set	20
329042	200	set	22
329043	250	set	26

Additionally or later purchased, hardened jaws must be ground out in the chuck.
For jaws which are applied later, send in the chuck.

A28

Inside jaw BB, set, outward stepped jaw, hardened



Item no.	Chuck Size	Contents of delivery	Jaw width
329038	160	set	20
329039	200	set	22
329040	250	set	26

Additionally or later purchased, hardened jaws must be ground out in the chuck.
For jaws which are applied later, send in the chuck.

A28

Unstepped top jaw AB, set, soft, material 16MnCr5



Item no.	Chuck Size	Contents of delivery	Jaw length	Jaw height	Jaw width
329044	160	set	90	36,5	20,3
329045	200	set	100	40	22
094010	250	set	125	50	30,4

A28

Base jaw GB, set, hardened, with mounting bolts



Item no.	Chuck Size	Contents of delivery	Jaw length	Jaw height	Jaw width
329047	160	set	74	8	20
329048	200	set	90	10	22
329049	250	set	110	12	26

C15

Jaw mounting bolt, 1 piece



Item no.	Chuck Size	Thread	Contents of delivery
200182	160/200	M8x1x22	piece
200183	250	M12x1,5x30	piece

Accessories DURO-TA

Accessories DURO-TA

A08

Base plate with fixing slots

Complete with mounting screws and fixed T-slot nuts. Other sizes available on request.



Item no.	Size
143163	160
143165	200
143167	250

A08

Key



Item no.	Size	Square	L mm
094016	160	10	140
094017	200	12	160
094018	250	14	220

Only for stationary used chucks

A08

Safety key



Item no.	Size	Square	L mm
242173	160	10	140
242174	200	12	160
242175	250	14	220

corresponding with DIN 1550 for rotating chucks

A08

Chip guard, set



Item no.	Size	Contents of delivery
236439	160	set
236440	200	set
236441	250	set

A08

Special grease F80 for lathe chucks

For lubrication and conservation of chucking power



Item no.	Design	Contents
308555	Cartridge	0,5 kg
028975	Tin	1 kg

Technical data DURO-TA

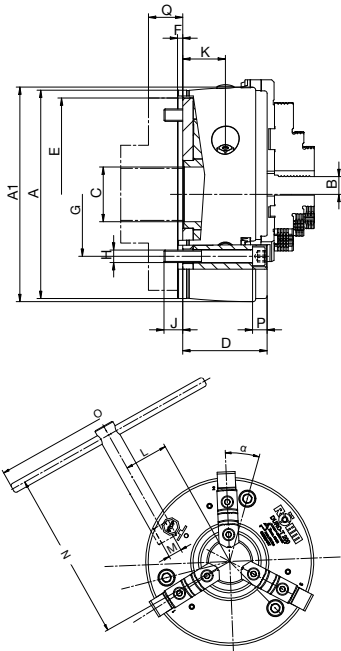

Chuck size		160	200	250
Outer diameter	A	160	206	255
Jaw movement	B	6,2	6,8	8
Bore	C	42	52	62
Bore can be enlarged	C max.	45	55	75
	D	63	81	92
	E ^{H6}	145	185	235
	F	5	5	6
	G	125	160	200
	H	3xM10	3xM12	3xM16
	J	15	18	25
	K	31,5	43	47
	L	42	53,5	66,5
	M	SW10	SW12	SW14
	N	182	211	284
	O	210	270	450
	P	13	14	17
Min. thickness of flange	Q	30	30	35
Moment of inertia ¹⁾	kgm ²	0,03	0,10	0,29
	α	22°	18°	19°
Weight approx	kg	9,5	20°	35

1) The moment of inertia was measured with base jaws but without top jaws or back plate
The bore could be enlarged (measure C, at surcharge)

■ Enlarged bore max.

Max. permissible speed

The maximum permissible speed has been fixed so that 1/3 of the gripping force is still available as residual gripping force if the maximum gripping is applied and the chuck is fitted with its heaviest jaws. The jaws may not project beyond the outside diameter of the chuck. The chuck must be in perfect condition. The specification DIN 6386 Part 1 shall be observed.

Chuck size		160	200	250
Max. speed	min ⁻¹	5400	4600	4200

Gripping force

The gripping force is the sum total of all jaw forces acting radially on the stationary workpiece.
The specified gripping forces are standard values.

They apply to chucks in a perfect condition which have been lubricated with RÖHM grease F79 and F80.

Chuck size		160	200	250
Torque applied on key in1)	Nm	20	30	35
Total gripping force1)	kN	15	24	33
Torque applied on key in	Nm	120	155	190
Max. total gripping force	kN	73	114	185

1) maintaining the accuracy

Chucking capacities of jaw steps

Chuck size		160	200	250	
External chucking	Jaw position.	A1	5-51	7-70	8-97
		A2	45-91	58-123	82-172
		A3	89-135	114-179	-
		A4	115-161	142-207	163-253
Internal chucking		J1	67-105	71-131	99-182
		J2	93-132	99-159	-
		J3	135-174	154-214	178-261

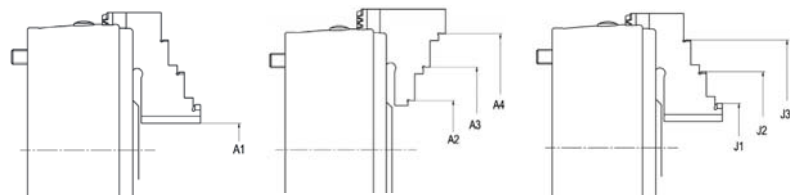
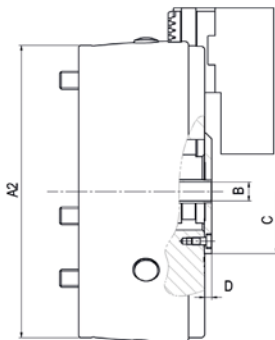

Chuck dimensions DURO-TA - Main dimensions (other dimensions on the table on the top)

Chuck size		160	200	250
Outer diameter	A	160	206	255
External chucking with BB-jaws		3-46	3-60	5-66
External chucking with DB-jaws		23-160	32-200	65-243
Internal chucking with BB jaws		28-156	32-195	47-225
Central bor for coolant	B	13	13	13
	C	70	85	92
	D	5	6	5

Jaw dimensions and chucking capacity DURO-TA

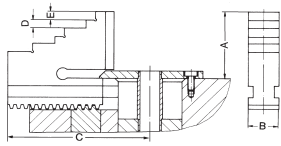

Outward stepped jaw **BB**

Chuck size	160	200	250
A	46	55	60
B	20	22	26
C max.	95	120	143,5
C min.	72	91	113
D	5	7	6
E	6	6	8
Jaw approx. kg	0,465	0,643	1,065

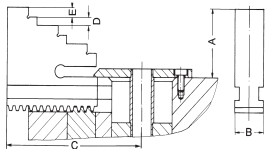

Inward stepped jaw **DB**

Chuck size	160	200	250
A	43	50	50
B	20	22	26
C max.	95	120	143,5
C min.	72	91	113
D	5	7	6
E	6	6	8
Jaw approx. kg	0,435	0,600	1,065

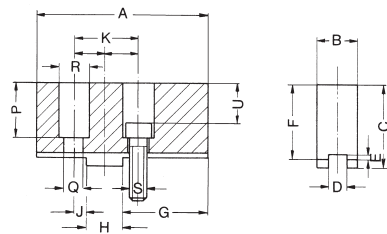

Unstepped soft top jaw **AB**

Chuck size	160	200	250
A	90	100	125
B	20,3	22	30
C	41	45	55
D	8	10	12
E	3	3,5	3,5
F	36,5	40	50
G	55	61	70
H	18	20	20
J	6	6	10
K	30	32	40
P	27,5	31	39
Q	9	9	14
R	15	15	20
S	M8x1	M8x1	M12x1,5
U	19,5	23	27
Jaw approx. kg	0,435	0,800	1,500

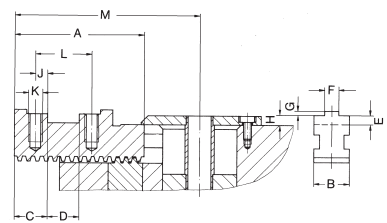

Base jaw **GB**

Chuck size	160	200	250
A	74	90	110
B	20	22	26
C	17	19	26
D	18	20	20
E	5	5,5	5,5
F	8	10	12
G	2,5	7	7
H	6	20	20
J	7	6	10
K	M8x1	M8x1	M12x1,5
L	32	32	40
M max.	105	127	148,5
M min.	91	103	125
Jaw approx. kg	0,335	0,365	0,700

Jaw dimensions and chucking capacity