

**STD / StdFLEX / OK Series
MORSE - VISES**

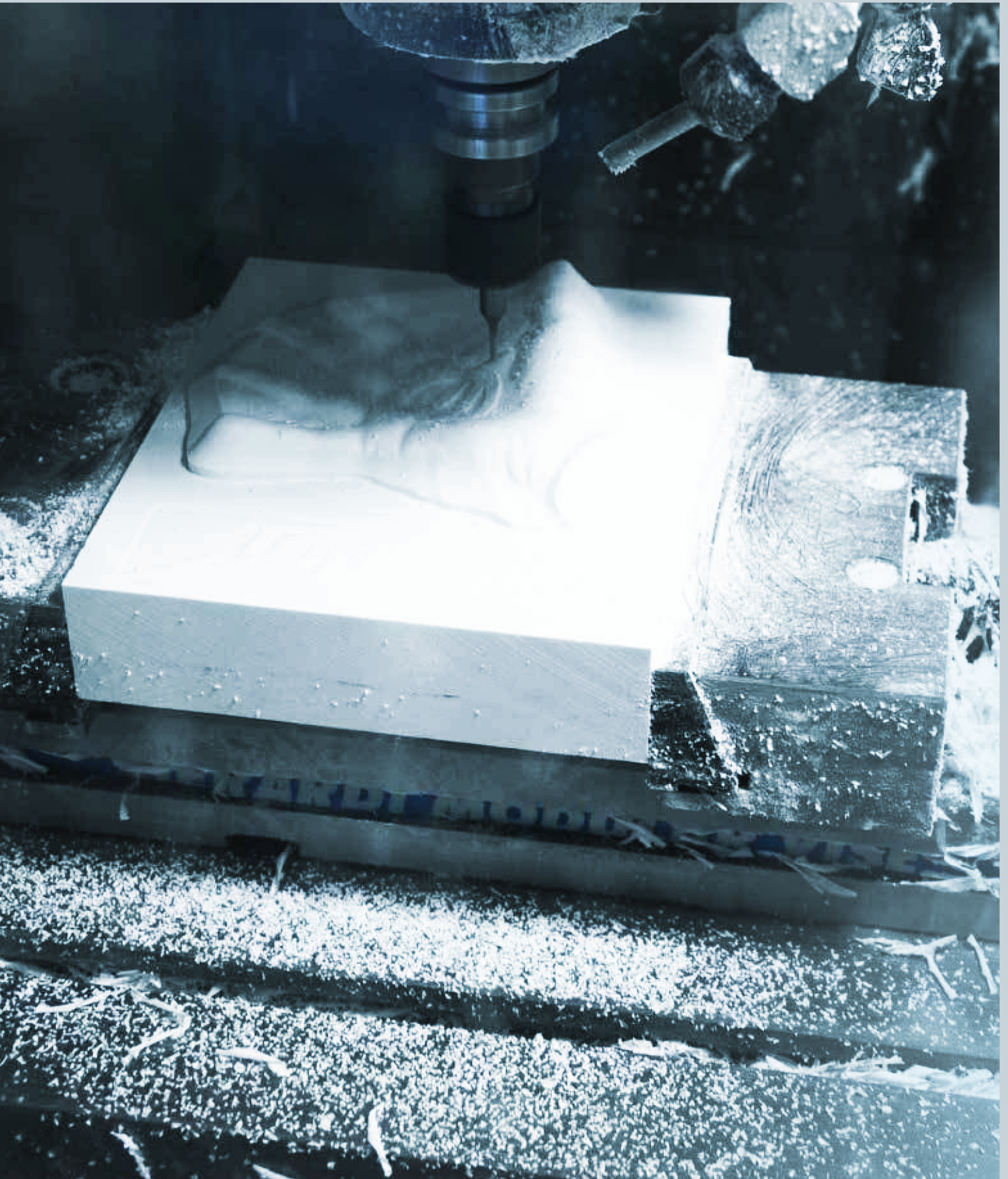

INDICE - INDEX

Art.	Page 1.
1	6
1A	18
1AZ	20
1Z	8
12	10
14	12
15	14
40	22
40A	22
40Z	22
62	22 - 39 - 41
99	39 - 41
99B	39 - 41
99H	39 - 41
99S	39 - 41
99T	39 - 41
130	32
130S	32
131	32
131A	32
131AS	32
131S	32
136	32
136S	32
137	32
137S	32
138	32
138D	32
138DS	32
138S	32
139	32
139D	32
139DS	32
139S	32
150	32
150A	32

Art.	Page 1.
150AS	32
150S	32
212	6 - 8 - 12 - 18 - 20
213	10
217	6 - 8
218	10 - 14
230B	18 - 20
230E	18 - 20
230F	18 - 20
242G	6 - 8
243G	10
246	12
246G	12
247	14
247G	14
271	6 - 8 - 10 - 12 - 14
313	6 - 8 - 12
313R	10 - 14
391	6-8-10-12-14-18-20
392	6-8-10-12-14-18-20
450	28
666	44
666A	45
666AS	45
666B	45
666BS	45
666C	45
666CS	45
666D	45
666DS	45
666E	45
666ES	45
666F	45
666FS	45
666G	45
666GS	45

Art.	Page 1.
666H	45
666HS	45
666I	45
666IS	45
666L	45
666LS	45
666M	45
666MS	45
666N	45
666NS	45
666O	45
666OS	45
666S	44
667	47
668	47
671	46
672	48
672A	49
672B	49
672C	49
672D	49
672E	49
672F	49
672G	49
672H	49
672I	49
672J	49
700	26
701	28
750	26
828	28
828A	28
981	3
DIVIGER 205	40
DPG250	38

VALIGETTA DI CAMPIONATURA STD (Art.1)

SAMPLE KIT CASE STD (Art.1)

NEW!

Art. 981

 Valigetta di campionatura morsa Art.1 T.1
 Sample kit case Art.1 T.1 vise

Cod. 0.98.10000

All'Interno - Inside:

	Art.132		Art.313		Art.298
	Art.133		Art.314		Art.370
	Art.138		Art.271		Art.375
	Art.147		Art.283		Art.376
	Art.212		Art.285	-	-
	Art.217		Art.297	-	-

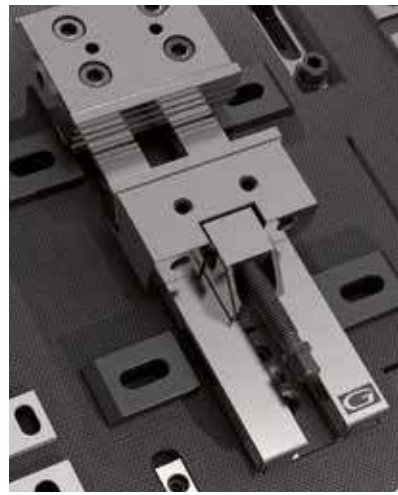

SIMBOLOGIA DATI TECNICI

TECHNICAL DATA ICONS

GANASCE JAWS		Fissa Fixed		Mobile Movable		Intermedia Intermediate		Fissa con piastra singola Fixed with single plate		Fissa con piastra doppia Fixed with double plate		Ganasce sovrapponibili Stack Type Jaws		
		Discendente Pull down		Piana Straight		Cambio rapido manuale Quick manual change		GRIP GRIP		Inserti GRIP Inserti GRIP				
POSSIBILITÀ DI POSSIBILITY OF		Serraggio di 1 particolare Clamping only 1 piece		Serraggio di 2 particolari Clamping 2 pieces		Montaggio sul fianco o in serie Side mounting or gang operation		Posizionamento & cambio rapido Quick change & positioning		Cubi-morsa Vise tower		Divisore Automatico Automatic dividing head		Divisore Meccanico Mechanical dividing head
		Accessori & Ricambi Accessories & Spare Parts		Istruzioni corretto utilizzo Instruction for a proper use		Diagrammi forze di serraggio Clamping force diagrams		Sistema Idramico Hydraulic System						

MORSE e CUBI serie STANDARD

STANDARD series VISES and CUBES

La Morsa più diffusa (ed imitata nel mondo). Il trinomio perfetto: Convenienza, Qualità, Versatilità
The Most popular (and copied) vise in the world. The perfect mix: Price, Quality, Versatility

La morsa componibile **GERARDI** è costruita con il concetto di **intercambiabilità** di tutti gli elementi componenti l'attrezzatura e con la certezza di poter usare più morse sulla stessa macchina con **posizionamento ed allineamento perfetto in pochi secondi**. Tutto ciò è possibile per l'elevato grado di precisione della morsa stessa ed in particolare per quanto riguarda: l'altezza della base, l'allineamento con tasselli di cava longitudinale rispetto alla ganaschia fissa, la perpendicolarità della ganaschia fissa rispetto alla base ed il parallelismo dei piani della base. Tali caratteristiche consentono di risolvere più svariati e complicati problemi di fissaggio in pochi istanti con l'uso di più morse.

All **GERARDI** vises and accessories are modular and components of all our vises will **interchange** with perfect alignment. The vises can be matched side to side with the **highest precision and minimum of set up times** thanks to many fixed reference points. All this is possible thanks to the high precision of the vise particularly as regards: the base high, the alignment with longitudinal key-nuts with respect to the fixed jaw, the perpendicularity of the fixed jaw with respect to the vise base and the parallelism of the base top and bottom surfaces. Those features allows us to solve the most varied and complicated problems of clamping in a few seconds with the use of more vises.



USURA INESISTENTE

Grazie all'accurata scelta dei materiali impiegati ed allo studio dimensionale computerizzato dei componenti. **Costruzione completamente in speciali leghe di acciaio** ad alta resistenza, normalizzato, cementato e temprato con **durezza 60 ±2 HRC**. Tutto ciò al fine di conferire massima rigidità, elevate prestazioni e usura inesistente. A riprova di tutto ciò assicuriamo **5 ANNI DI GARANZIA** su tutto il programma morse e organi meccanici in genere.

NO WEAR

Thanks to the manufacturing with only the most suitable materials and to the structure of the vise components (developed using computer customised softwares and the experience gained during many years spent working on the specific field). **High alloyed quality resistance steel, case hardened HRC 60 ±2**, is used in manufacturing all the Gerardi vises and accessories in order to give maximum rigidity, high performances and no wear. As evidence we give **5 YEARS WARRANTY** on all the vises and mechanical components.



DESIGN COMPATTO E MANEGGEVOLEZZA

La semplicità nonché la compattezza costruttiva consentono un'apertura notevole rispetto all'ingombro totale dell'attrezzatura. Inoltre lo stesso peso (solo 25 kg per una morsa da 150 mm di larghezza ganaschia) è tale da consentire un facile trasferimento da una macchina all'altra.

SPACE SAVING DESIGN & HANDY

The space saving design and solid construction allow a maximum blocking ratio to total overall dimension of the vise. Furthermore the weight (only 25 kg for a 150 mm jaw width vise) allows a simple moving from one machine to another.



MODULARITÀ

Tutte le morse ed accessori sono elementi componibili, intercambiabili e perfettamente allineabili fra loro e con i quali è possibile ottenere differenti soluzioni di bloccaggio. Secondo tale principio l'unico elemento che differenzia le attrezzature con identica larghezza di presa è la base (la cui lunghezza determina la massima apertura della morsa), mentre gli altri componenti sono identici. Mediante l'aggiunta o semplice sostituzione di alcuni particolari si può variare la tipologia di bloccaggio secondo le proprie esigenze utilizzando la stessa attrezzatura acquistata in un primo momento (bloccaggi singoli, con base girevole, doppi, verticali, di pezzi piani, tondi, piatti e grezzi, manuali, idraulici o pneumatici).

MODULARITY

All vises and accessories are modular and components of all our vises will interchange with perfect alignment to provide different workholding solutions. With this basic principle the only difference between fixtures with the same width of clamping is the base (whose length determines the maximum opening of the vise), while the rest of components have same dimensions. Through the simple addition or substitution of some particulars You can change the type of clamping as Your needs require using the same fixture purchased before (single clamping, swivel base, double, vertical, smooth or round or flat or rough workpieces, manual, hydraulic or pneumatic).



RAPIDITA' DEI SERRAGGI

Grazie allo scorrimento del gruppo di serraggio nella guida della base (a cremagliera) fino in prossimità del pezzo da lavorare dove si adatterà automaticamente alla nicchia più vicina. L'operazione di serraggio si conclude agendo sulla vite di bloccaggio. Oltre a quello manuale meccanico, sono disponibili 4 ulteriori sistemi di serraggio intercambiabili e indipendenti:

1 - Idraulici / 2 - Pneumatici / 3 - Idraulici manuali / 4 - Idraulici elettrici.
 L'operazione è in termini di secondi.

QUICK CLAMPING

Thanks to the clamping device sliding in the vise base slide (compact rack type) till the proximity of the workpiece. The clamping is completed with the main screw. Besides the manual mechanic system, 4 further interchangeable and independent clamping systems are available: 1- Hydraulic / 2- Pneumatic / 3- Manual hydraulic / 4- Electrical hydraulic. The change needs only few seconds.

1 VERSATILITA'

La **ganascia fissa con gradino posteriore di 5x5 mm** consente, una volta ruotata di 180°, il perfetto accoppiamento al gradino della ganascia prismatica mobile (**Art.217**) ordinabile separatamente: è così possibile il serraggio di pezzi piatti senza parallele e di tondi sia in orizzontale che in verticale. Inoltre è disponibile una **vastissima gamma di ganasce** nonché un sistema di parallele piane e angolari per le più svariate applicazioni e la lavorazione di pezzi di qualsiasi forma e dimensione. **Illimitata gamma di aperture possibili.**

1 VERSATILITY

Fixed jaw with 5x5mm step matchable to the prismatic movable jaw (Art.217 to be ordered separately) which allows to clamp plates without parallels and round workpieces vertical & horizontal way. Vertical, sideway and gang operation are possible with the appropriate components (column, narrow width jaws, etc.) **Unlimited calmping range.**

2 PRECISIONI ± 0,02 mm

Slittone base con tutte le superfici di scorrimento ed accoppiamento rettificata. L'allineamento agli assi della macchina avviene grazie alle **chiavette longitudinali e trasversali (16H7)** o fori di posizionamento (Ø16mm F7), a richiesta, previsti sulla base di ciascuna morsa. Naturalmente tutto ciò consente oltre alle precisioni dichiarate **tempi di installazione ristrettissimi.**

2 HIGHEST ACCURACIES ± 0,02 mm

Solid vise base. Every sliding and coupling surface is ground. **Centesimal tolerances** are guaranteed by checking cycles with CNC measuring machine. The perfect alignment with the machine axis is given by **longitudinal and cross keyways (16H7)** or positioning holes (Ø16 mm F7), upon specific request, on the vise base. Of course this allows **minimum of set up times and gang operations.**

Art. 1

Morsa modulare di precisione STD con ganascia mobile monoblocco guidata

STD precision modular vise with solid guided movable jaw

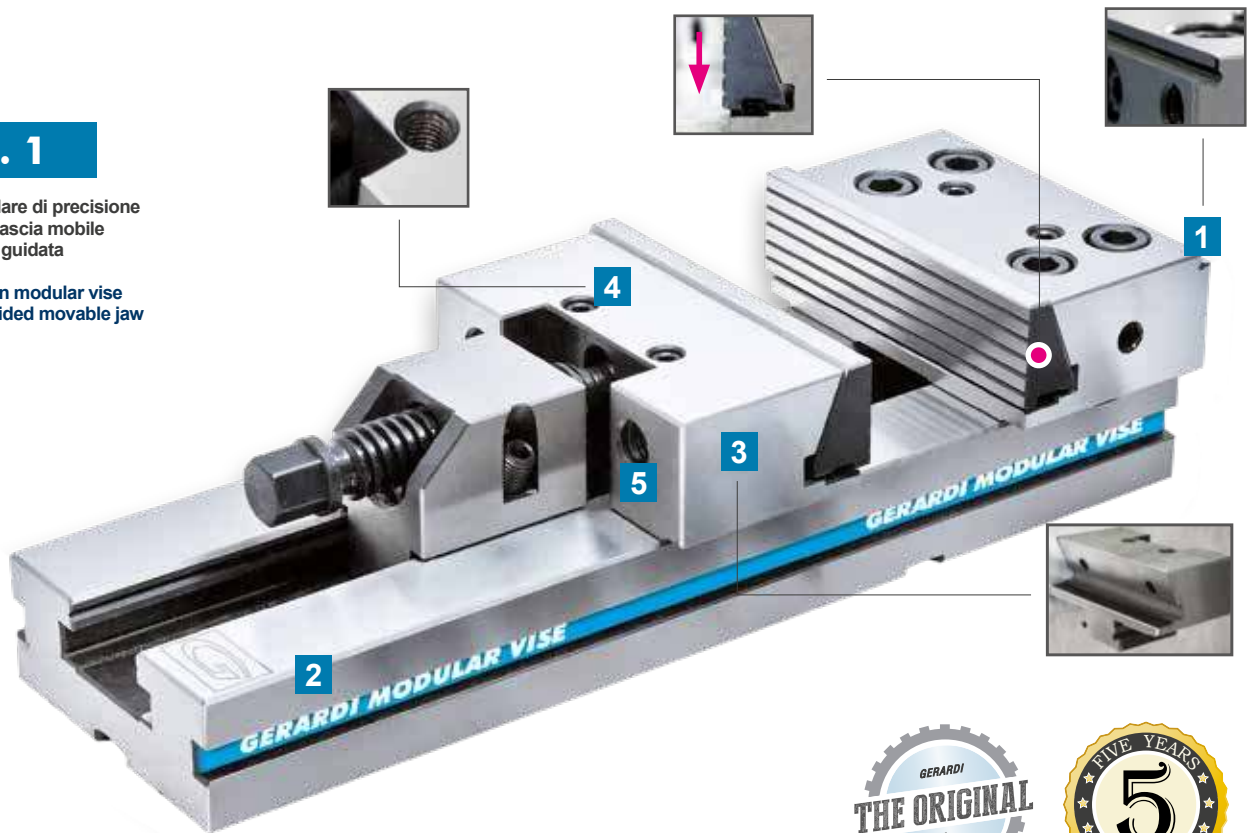

3 RIGIDITA' e SICUREZZA

Entrambe le ganasce sono costruite in corpo unico (non esistono slitte o tasselli di fissaggio) per garantire una maggiore rigidità e nessuna flessione. Entrambe le piastre ganasce sono costruite con **un angolo di spinta verso il basso**. Ciò assicura, nel momento della chiusura, una trazione del pezzo contro la base della morsa (per trascinamento) e, di conseguenza, un bloccaggio sicuro e preciso.

3 RIGIDITY and SAFETY

Both jaws bodies are built in one solid piece (no slides or key-nuts): in order to guarantee higher rigidity & no bendings. Both jaw plates are manufactured with a **pull down angle**. This ensure, during the clamping operation, a downward run of the workpiece against the vise base (by dragging) and thus a precise and safety clamping.

4 FORI GANASCIA PER APPLICAZIONI SPECIALI

Quattro fori filettati supplementari sopra le ganasce danno la possibilità di installare ganasce sovrapponibili per applicazioni speciali.

4 JAW HOLES FOR SPECIAL APPLICATIONS

4 extra tapped holes over the jaws for special Gerardi stack type jaw application

5 INCREMENTO APERTURA MASSIMA

Quattro fori filettati supplementari e la parte posteriore di ciascuna ganascia rettificata permettono di incrementare la capacità di apertura di circa l'80% tramite il fissaggio di appositi elementi di prolunga (Art.132 e 133 da ordinare separatamente).

5 MAX OPENING INCREASE

4 extra tapped holes with ground back jaw rear face increase maximum opening capacity of about 80% with the addition of jaw extensions (Art.132 and 133 to be ordered separately).

Tipo (grandezza) morsa / Vise type (size)	kN	1		2		3		4	
		16 kN	25 kN	30 kN	30 kN	30 kN	30 kN	30 kN	
Apertura massima / Maximum spread	A	100	150	200	300	200	300	400	500
	W	100	125	150		175			
	B	30	40	50		60			
	C	35	40	50		58			
	D	270	345	420	520	455	555	655	755
	G	75	95	125		145			
	kg	6.8	12.9	25.5	29	37	42	47	52
	Cod.	3.01.00000	3.02.10000	3.03.20000	3.03.30000	3.04.20000	3.04.30000	3.04.40000	3.04.50000

Art. 1

Morsa modulare di precisione STD con ganaschia mobile monoblocco guidata

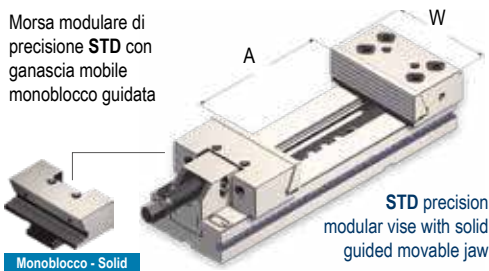

STD precision modular vise with solid guided movable jaw

Monoblocco - Solid

AMPLIA LE TUE APPLICAZIONI TRAMITE GLI ACCESSORI MODULARI !

Art. 313

Piastra magnetica parallele piane
Magnetic parallel plates

Vedi pagina 4.20 per altezze disponibili
See page 4.20 for available height

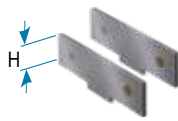

Cod.	4.31.31000	4.31.32000	4.31.33000	4.31.34000
H	23	33	43	53

Art. 212

Ganaschia mobile intermedia
(da usare con Art. 313)

Intermediate movable jaw (to be used with Art. 313)



Cod.	1.21.21000	1.21.22000	1.21.23000	1.21.24000
------	------------	------------	------------	------------

Art. 217

Ganaschia mobile prismatica
Prismatic movable jaw



Cod.	2.21.71000	2.21.72000	2.21.73000	2.21.74000
------	------------	------------	------------	------------

Art. 242G

NEW!

Piastra ganaschia con inserti GRIP
Jaw plate with GRIP inserts



Cod.	1.24.2G100	1.24.2G200	1.24.2G300	1.24.2G400
------	------------	------------	------------	------------

Art. 271

Supporto di serraggio con cilindro idraulico
Clamping support with hydraulic cylinder



Cod.	2.27.11000	2.27.12000	2.27.13000	2.27.14000
------	------------	------------	------------	------------

Art. 271

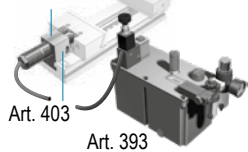

Art. 391

CNC / CNC

Art. 392

Pneumatico / Air control

Cod.	4.39.11000	4.39.12000	4.39.13000	4.39.14000
Cod.	4.39.21000	4.39.22000	4.39.23000	4.39.24000

Servocomandi oleopneumatici (completi di 1 cilindro e supporto) per serraggi multipli **contemporanei** o **indipendenti**, da 2 a 6 morse. Vedi da pag. 4.38 a 4.49

Dotazione standard:

- 1 arresto laterale Art. 370
- 1 coppia di tasselli di posizionamento Art. 297
(Standard per cava da 16 mm; altre dimensioni a richiesta senza variazione di prezzo)
- 1 chiave a pipa Art. 375 ■ 1 chiave a "T" Art. 376

Extra per ogni foro calibrato (tolleranza F7):

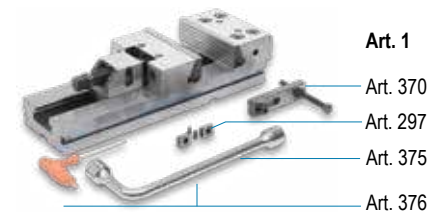

Standard equipment:

- 1 workshop Art. 370
- 1 pair of positioning key-nuts Art. 297
(Standard for 16 mm slot. Other dimensions available on request without price change)
- 1 box wrench Art. 375 ■ 1 T-wrench Art. 376

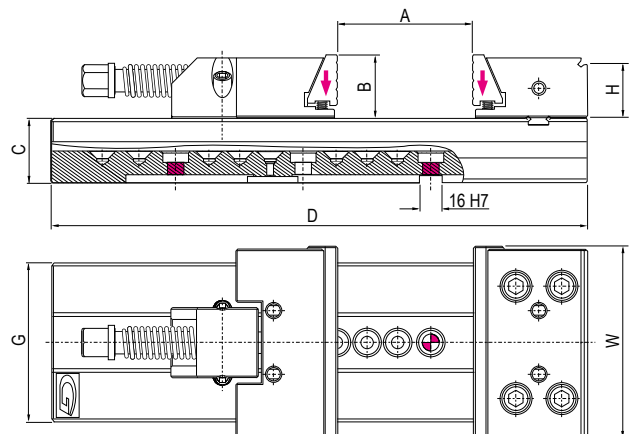

Extra charge for each calibrated hole (F7 tolerance):



Vedi gruppo 4 per gamma completa accessori
See group 4 for complete range of accessories

5 40 kN					6 40 kN						
200	300	400	500	600	200	300	400	500	600	700	800
		200						300			
		65						80			
		70						78			
495	595	695	795	895	535	635	735	835	935	1035	1135
		170						195			
64	69	74	79	84	95	105	115	125	135	145	155
3.05.20000	3.05.30000	3.05.40000	3.05.50000	3.05.60000	3.06.20000	3.06.30000	3.06.40000	3.06.50000	3.06.60000	3.06.70000	3.06.80000

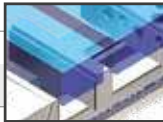
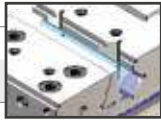
UPGRADE YOUR VISE APPLICATIONS THROUGH MODULAR ACCESSORIES !

Art. 313	4.31.35000		4.31.36000
	53		68
Art. 212	1.21.25000		1.21.26000
Art. 217	2.21.75000		2.21.76000
Art. 242G	1.24.2G500		1.24.2G600
Art. 271	2.27.15000		2.27.16000
Art. 391	4.39.15000		4.39.16000
Art. 392	4.39.25000		4.39.26000

 Pneumo-hydraulic servo units (complete of hydraulic cylinder + support) for multiple clamping *simultaneous* or *independent*, from 2 to 6 vises. See from page 4.38 to 4.49

Art. 1

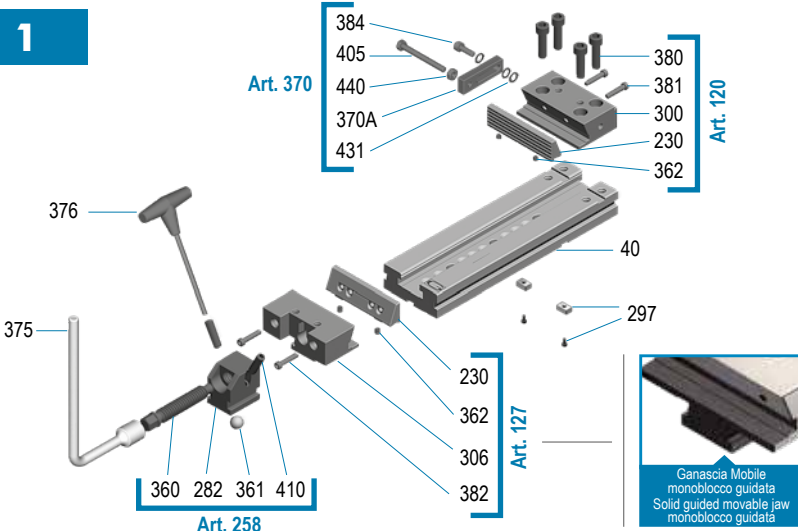

Art. 370: 384, 405, 440, 370A, 431

Art. 120: 380, 381, 300, 230, 362

Art. 258: 376, 375, 360, 282, 361, 410

Art. 127: 230, 362, 306, 382

Art. 120 inset: 297

Inset: **Ganascia Mobile monoblocco guidata**
Solid guided movable jaw monoblocco guidata

Art.	Pag.	Art.	Pag.
40	1.22	376	4.33
230	4.9	380	4.26
282	4.34	381	4.26
297	4.33	382	4.26
300	4.27	384	4.26
306	4.27	405	4.33
360	4.34	410	4.34
361	4.34	431	4.26
362	4.26	440	4.26
370A	4.33	-	-
375	4.33	-	-

Tipo (grandezza) morsa / Vise type (size)	kN	1		2		3		4	
		16 kN	25 kN	30 kN	30 kN	30 kN	30 kN	30 kN	
Apertura massima / Maximum spread	A	100	150	200	300	200	300	400	500
Art. 1Z	W	100	125	150		175			
	B	30	40	50		60			
	C	35	40	50		58			
	D	270	345	420	520	455	555	655	755
	G	75	95	125		145			
	kg	7.3	13.2	26.2	29.7	37.9	43	48.1	53.2
	Cod.	1.1Z.10000	1.1Z.20000	1.1Z.32000	1.1Z.33000	1.1Z.42000	1.1Z.43000	1.1Z.44000	1.1Z.45000

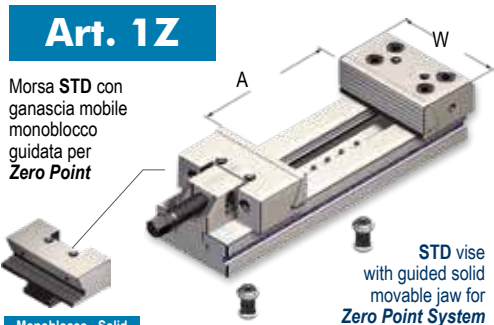
AMPLIA LE TUE APPLICAZIONI TRAMITE GLI ACCESSORI MODULARI !

Art. 313	Cod.			
	4.31.31000	4.31.32000	4.31.33000	4.31.34000
H	23	33	43	53

Art. 212	Cod.			
	1.21.21000	1.21.22000	1.21.23000	1.21.24000

Art. 217	Cod.			
	2.21.71000	2.21.72000	2.21.73000	2.21.74000

Art. 242G	Cod.			
	1.24.2G100	1.24.2G200	1.24.2G300	1.24.2G400

Art. 271	Cod.			
	2.27.11000	2.27.12000	2.27.13000	2.27.14000

Art. 271	Cod.			
	4.39.11000	4.39.12000	4.39.13000	4.39.14000

Art. 392	Cod.			
	4.39.21000	4.39.22000	4.39.23000	4.39.24000

 Servocomandi oleopneumatici (completi di 1 cilindro e supporto) per serraggi multipli **contemporanei** o **indipendenti**, da 2 a 6 morse. Vedi da pag. 4.38 a 4.49

Dotazione standard:

- 1 arresto laterale Art. 370
- 2 tiranti Art. 10A
- 1 chiave a pipa Art. 375
- 1 chiave a "T" Art. 376

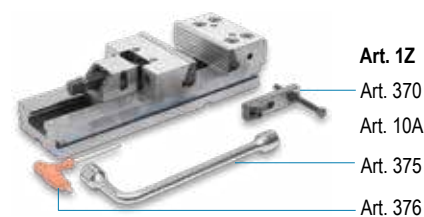
Standard equipment:

- 1 workshop Art. 370
- 2 pullstuds Art. 10A
- 1 box wrench Art. 375
- 1 T-wrench Art. 376

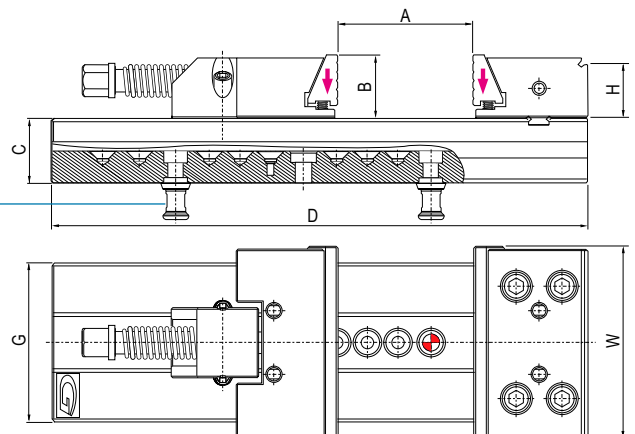
 Vedi gruppo 4 per gamma completa accessori
 See group 4 for complete range of accessories

5 40 kN					6 40 kN						
200	300	400	500	600	200	300	400	500	600	700	800
		200						300			
		65						80			
		70						78			
495	595	695	795	895	535	635	735	835	935	1035	1135
		170						195			
65.3	70.3	75.3	80.3	85.3	97	107	117	127	137	147	157
1.1Z.52000	1.1Z.53000	1.1Z.54000	1.1Z.55000	1.1Z.56000	1.1Z.62000	1.1Z.63000	1.1Z.64000	1.1Z.65000	1.1Z.66000	1.1Z.67000	1.1Z.68000

UPGRADE YOUR VISE APPLICATIONS THROUGH MODULAR ACCESSORIES !

Art. 313	4.31.35000		4.31.36000
	53		68
Art. 212	1.21.25000		1.21.26000
Art. 217	2.21.75000		2.21.76000
Art. 242G	1.24.2G500		1.24.2G600
Art. 271	2.27.15000		2.27.16000
Art. 391	4.39.15000		4.39.16000
Art. 392	4.39.25000		4.39.26000

 Pneumo-hydraulic servo units (complete of hydraulic cylinder + support) for multiple clamping *simultaneous* or *independent*, from 2 to 6 vises. See from page 4.38 to 4.49

Art. 1Z

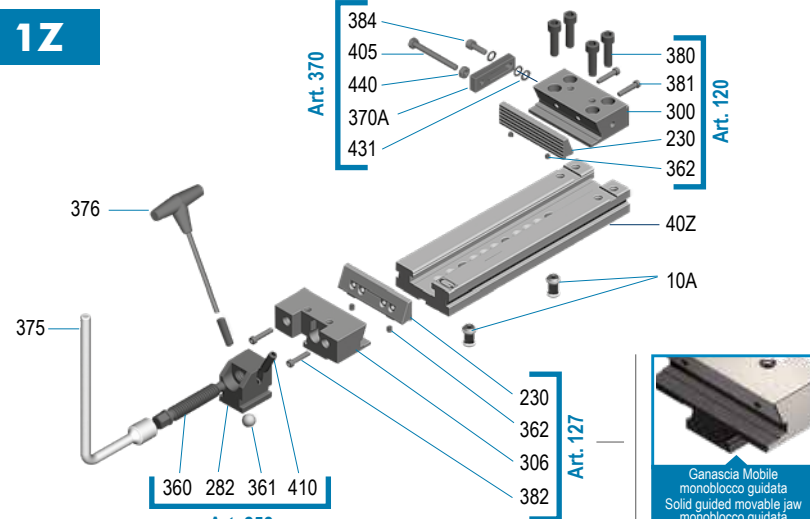

Art.	Pag.	Art.	Pag.
10A	9.31	376	4.33
40Z	1.22	380	4.26
230	4.9	381	4.26
282	4.34	382	4.26
300	4.27	384	4.26
306	4.27	405	4.33
360	4.34	410	4.34
361	4.34	431	4.26
362	4.26	440	4.26
370A	4.33	-	-
375	4.33	-	-



Ganascia Mobile monoblocco guidata
Solid guided movable jaw monoblocco guidata

Tipo (grandezza) morsa / Vise type (size)	kN	1		2		3		4	
		16 kN	25 kN	30 kN	30 kN	30 kN	30 kN	30 kN	
Apertura massima / Maximum spread	A	100	150	200	300	200	300	400	500
Art. 12 Morsa STD con ganasce ridotte rettificate. (Maggior Pressione)	W	75	95	125		145			
	B	30	40	50		60			
	C	35	40	50		58			
	D	270	345	420	520	455	555	655	755
	G	75	95	125		145			
kg		6.2	11.9	24.2	27.8	35	39	46	51
Cod.		3.01.00120	3.02.10120	3.03.20120	3.03.30120	3.04.20120	3.04.30120	3.04.40120	3.04.50120

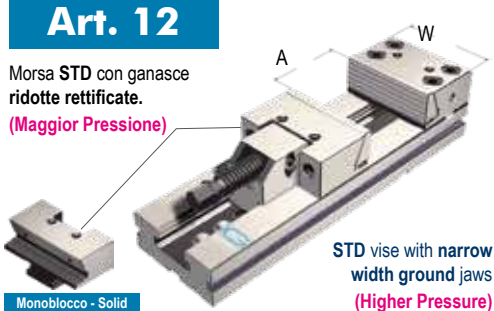
AMPLIA LE TUE APPLICAZIONI TRAMITE GLI ACCESSORI MODULARI !

Art. 313R Piastrine magnetiche parallele piane Magnetic parallel plates Vedi pagina 4.20 per altezze disponibili See page 4.20 for available height	Cod.			
	4.31.3R100	4.31.3R200	4.31.3R300	4.31.3R400
H	23	33	43	53

Art. 213 Ganascia mobile intermedia (da usare con Art. 313R) Intermediate movable jaw (to be used with Art. 313R)	Cod.			
	1.21.31000	1.21.32000	1.21.33000	1.21.34000
H				

Art. 218 Ganascia mobile prismatica Prismatic movable jaw	Cod.			
	2.21.81000	2.21.82000	2.21.83000	2.21.84000

Art. 243G NEW! Piastra ganascia ridotta con inserti GRIP Narrow width jaw plate with GRIP inserts	Cod.			
	1.24.3G100	1.24.3G200	1.24.3G300	1.24.3G400

Art. 271 Supporto di serraggio con cilindro idraulico Clamping support with hydraulic cylinder	Cod.			
	2.27.11000	2.27.12000	2.27.13000	2.27.14000

Art. 271 Art. 403 Art. 393	Art. 391 CNC / CNC			
	4.39.11000	4.39.12000	4.39.13000	4.39.14000
Art. 392 Pneumatico / Air control	Cod.			
	4.39.21000	4.39.22000	4.39.23000	4.39.24000

 Servocomandi oleopneumatici (completi di 1 cilindro e supporto) per serraggi multipli **contemporanei** o **indipendenti**, da 2 a 6 morse. Vedi da pag. 4.38 a 4.49

- Dotazione standard:**
- 1 arresto laterale Art. 370
 - 1 coppia di tasselli di posizionamento Art. 297 (Standard per cava da 16 mm; altre dimensioni a richiesta senza variazione di prezzo)
 - 1 chiave a pipa Art. 375 ■ 1 chiave a "T" Art. 376
- Extra per ogni foro calibrato (tolleranza F7)

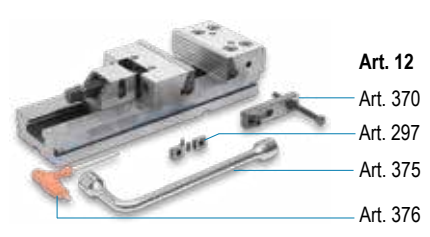

- Standard equipment:**
- 1 workshop Art. 370
 - 1 pair of positioning key-nuts Art. 297 (Standard for 16 mm slot. Other dimensions available on request without price change)
 - 1 box wrench Art. 375 ■ 1 T-wrench Art. 376
- Extra charge for each calibrated hole (F7 tolerance)

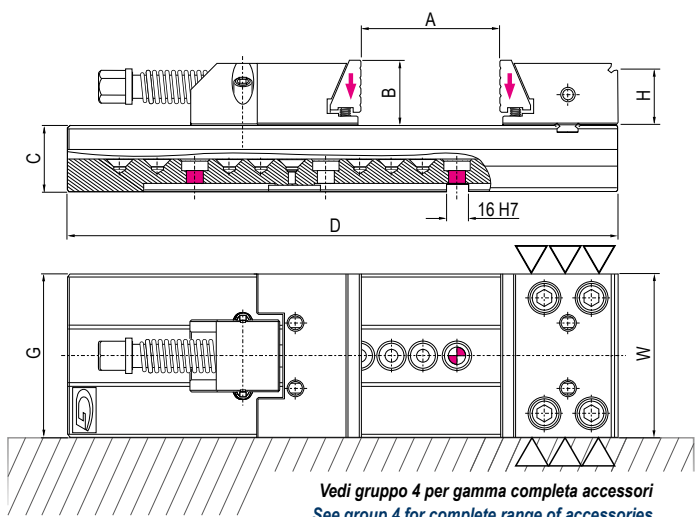

 Vedi gruppo 4 per gamma completa accessori
 See group 4 for complete range of accessories

5 40 kN					6 40 kN						
200	300	400	500	600	200	300	400	500	600	700	800
		170						195			
		65						80			
		70						78			
495	595	695	795	895	535	635	735	835	935	1035	1135
		170						195			
62	67	72	77	82	88	98	108	118	128	138	148
3.05.20120	3.05.30120	3.05.40120	3.05.50120	3.05.60120	3.06.20120	3.06.30120	3.06.40120	3.06.50120	3.06.60120	3.06.70120	3.06.80120

UPGRADE YOUR VISE APPLICATIONS THROUGH MODULAR ACCESSORIES !

Art. 313R	4.31.3R500		4.31.3R600
	53		68
Art. 213	1.21.35000		1.21.36000
Art. 218	2.21.85000		2.21.86000
Art. 243G	1.24.3G500		1.24.3G600
Art. 271	2.27.15000		2.27.16000
Art. 391	4.39.15000		4.39.16000
Art. 392	4.39.25000		4.39.26000

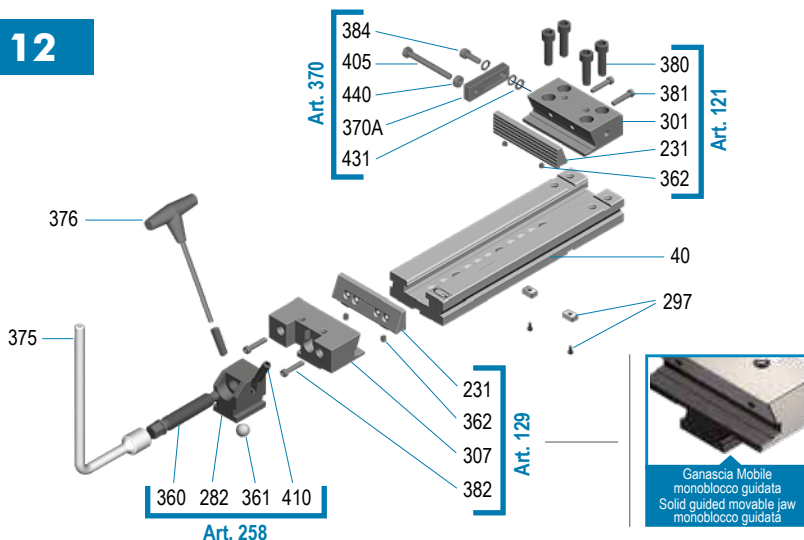
 Pneumo-hydraulic servo units (complete of hydraulic cylinder + support) for multiple clamping *simultaneous* or *independent*, from 2 to 6 vises. See from page 4.38 to 4.49

Art. 12

Art.	Pag.
40	1.22
231	4.9
282	4.34
297	4.33
301	4.27
307	4.27
360	4.34
361	4.34
362	4.26
370A	4.33
375	4.33

Art.	Pag.
376	4.33
380	4.26
381	4.26
382	4.26
384	4.26
405	4.33
410	4.34
431	4.26
440	4.26
-	-
-	-

Tipo (grandezza) morsa / Vise type (size)	kN	1		2		3		4	
		16 kN	25 kN	30 kN	30 kN	30 kN	30 kN	30 kN	
Apertura massima / Maximum spread	A	100	150	200	300	200	300	400	500
Art. 14 Morsa STD con ganasce a piastre piane 	W	100	125	150		175			
	B	30	40	50		60			
	C	35	40	50		58			
	D	270	345	420	520	455	555	655	755
	G	75	95	125		145			
	kg	6.8	12.9	25.5	29	37	42	47	52
	Cod.	1.14.10000	1.14.20000	1.14.32000	1.14.33000	1.14.42000	1.14.43000	1.14.44000	1.14.45000

AMPLIA LE TUE APPLICAZIONI TRAMITE GLI ACCESSORI MODULARI !

Art. 313 Piastre magnetiche parallele piane Magnetic parallel plates <small>Vedi pagina 4.20 per altezze disponibili See page 4.20 for available height</small>		1		2		3		4	
		Cod.	4.31.31000	4.31.32000	4.31.33000	4.31.34000	4.31.34000	4.31.34000	4.31.34000
H	23	33	43	53					

Art. 212 Ganasce mobile intermedia (da usare con Art. 313) Intermediate movable jaw (to be used with Art. 313)		1		2		3		4	
		Cod.	1.21.21000	1.21.22000	1.21.23000	1.21.24000	1.21.24000	1.21.24000	1.21.24000

Art. 246 Piastra piana in acciaio lavorabile Machinable steel straight jaw plate		1		2		3		4	
		Cod.	1.65.16200	1.65.26200	1.65.36200	1.65.46200	1.65.46200	1.65.46200	1.65.46200

Art. 246G NEW! Piastra piana con inserti GRIP Straight jaw plate with GRIP inserts		1		2		3		4	
		Cod.	1.24.6G100	1.24.6G200	1.24.6G300	1.24.6G400	1.24.6G400	1.24.6G400	1.24.6G400

Art. 271 Supporto di serraggio con cilindro idraulico Clamping support with hydraulic cylinder		1		2		3		4	
		Cod.	2.27.11000	2.27.12000	2.27.13000	2.27.14000	2.27.14000	2.27.14000	2.27.14000

Art. 271 Supporto di serraggio con cilindro idraulico Clamping support with hydraulic cylinder		1		2		3		4	
		Cod.	4.39.11000	4.39.12000	4.39.13000	4.39.14000	4.39.14000	4.39.14000	4.39.14000

Art. 391 CNC / CNC		1		2		3		4	
		Cod.	4.39.21000	4.39.22000	4.39.23000	4.39.24000	4.39.24000	4.39.24000	4.39.24000

Servocomandi oleopneumatici (completi di 1 cilindro e supporto) per serraggi multipli **contemporanei** o **indipendenti**, da 2 a 6 morse. Vedi da pag. 4.38 a 4.49

Dotazione standard:

- 1 arresto laterale Art. 370
- 1 coppia di tasselli di posizionamento Art. 297
(Standard per cava da 16 mm; altre dimensioni a richiesta senza variazione di prezzo)
- 1 chiave a pipa Art. 375 ■ 1 chiave a "T" Art. 376

Extra per ogni foro calibrato (tolleranza F7)

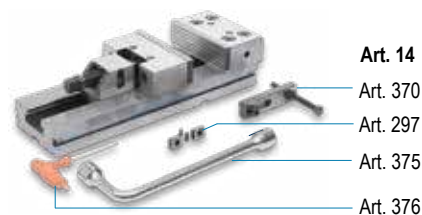

Standard equipment:

- 1 workstop Art. 370
- 1 pair of positioning key-nuts Art. 297
(Standard for 16 mm slot. Other dimensions available on request without price change)
- 1 box wrench Art. 375 ■ 1 T-wrench Art. 376

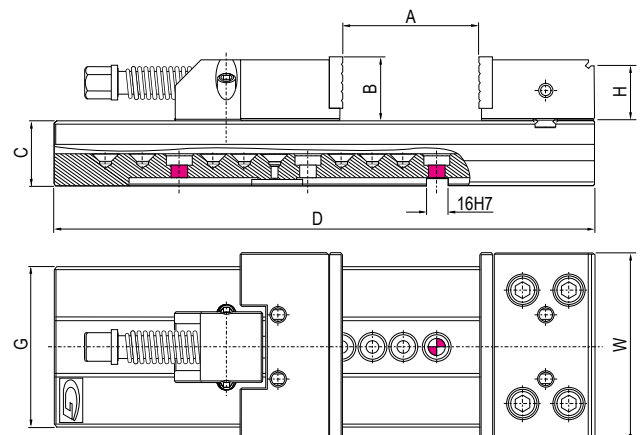

Extra charge for each calibrated hole (F7 tolerance)



Vedi gruppo 4 per gamma completa accessori
 See group 4 for complete range of accessories

5 40 kN					6 40 kN						
200	300	400	500	600	200	300	400	500	600	700	800
		200						300			
		65						80			
		70						78			
495	595	695	795	895	535	635	735	835	935	1035	1135
		170						195			
64	69	74	79	84	95	105	115	125	135	145	155
1.14.52000	1.14.53000	1.14.54000	1.14.55000	1.14.56000	1.14.62000	1.14.63000	1.14.64000	1.14.65000	1.14.66000	1.14.67000	1.14.68000

UPGRADE YOUR VISE APPLICATIONS THROUGH MODULAR ACCESSORIES !

Art. 313	4.31.35000		4.31.36000
	53		68
Art. 212	1.21.25000		1.21.26000
Art. 246	1.65.56200		1.65.66200
Art. 246G	1.24.6G500		1.24.6G600
Art. 271	2.27.15000		2.27.16000
Art. 391	4.39.15000		4.39.16000
Art. 392	4.39.25000		4.39.26000

Pneumo-hydraulic servo units (complete of hydraulic cylinder + support) for multiple clamping *simultaneous* or *independent*, from 2 to 6 vises. See from page 4.38 to 4.49

Art. 14

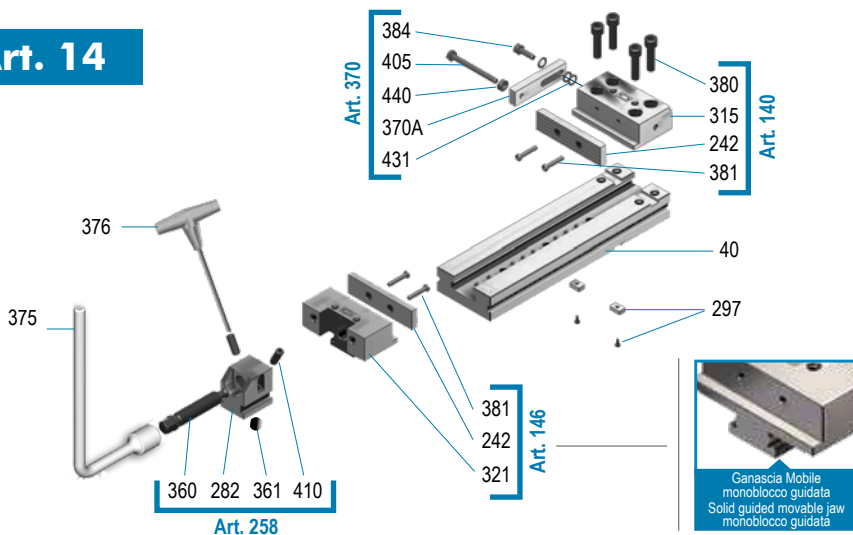

Art.	Pag.
40	1.22
242	4.11
282	4.34
297	4.33
315	4.28
321	4.28
360	4.34
361	4.34
370A	4.33
375	4.33
376	4.33

Art.	Pag.
380	4.26
381	4.26
384	4.26
405	4.33
410	4.34
431	4.26
440	4.26
-	-
-	-
-	-
-	-

Tipo (grandezza) morsa / Vise type (size)	kN	1		2		3		4	
		16 kN	25 kN	30 kN	30 kN	30 kN	30 kN	30 kN	30 kN
Apertura massima / Maximum spread	A	100	150	200	300	200	300	400	500
	W	75	95	125				145	
	B	30	40	50				60	
	C	35	40	50				58	
	D	270	345	420	520	455	555	655	755
	G	75	95	125				145	
	kg	6.2	11.9	24.2	27.8	35	39	46	51
	Cod.	1.15.10000	1.15.20000	1.15.32000	1.15.33000	1.15.42000	1.15.43000	1.15.44000	1.15.45000

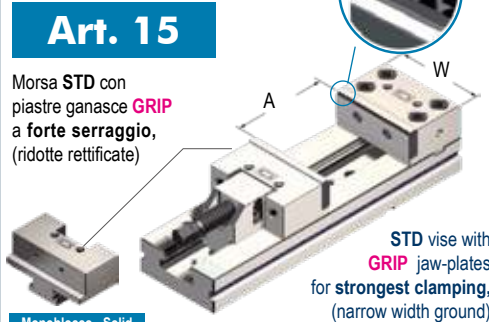
AMPLIA LE TUE APPLICAZIONI TRAMITE GLI ACCESSORI MODULARI !

Art. 313R	Cod.	4.31.3R100	4.31.3R200	4.31.3R300	4.31.3R400
Piastre magnetiche parallele piane Magnetic parallel plates	H	23	33	43	53

Art. 247	Cod.	1.65.17200	1.65.27200	1.65.37200	1.65.47200
Piastra piana ridotta in acciaio lavorabile Machinable steel narrow width straight jaw plate					

Art. 218	Cod.	2.21.81000	2.21.82000	2.21.83000	2.21.84000
Ganascia mobile prismatica Prismatic movable jaw					

Art. 247G	Cod.	1.24.7G100	1.24.7G200	1.24.7G300	1.24.7G400
Piastra piana ridotta con inserti GRIP Narrow width straight jaw plate with GRIP inserts					

Art. 271	Cod.	2.27.11000	2.27.12000	2.27.13000	2.27.14000
Supporto di serraggio con cilindro idraulico Clamping support with hydraulic cylinder					

Art. 271	Cod.	4.39.11000	4.39.12000	4.39.13000	4.39.14000
Art. 271					

Art. 391	Cod.	4.39.21000	4.39.22000	4.39.23000	4.39.24000
Art. 391 CNC / CNC					

 Servocomandi oleopneumatici (completi di 1 cilindro e supporto) per serraggi multipli **contemporanei** o **indipendenti**, da 2 a 6 morse. Vedi da pag. 4.38 a 4.49

Dotazione standard:

- 1 arresto laterale Art. 370
- 1 coppia di tasselli di posizionamento Art. 297
(Standard per cava da 16 mm; altre dimensioni a richiesta senza variazione di prezzo)
- 1 chiave a pipa Art. 375 ■ 1 chiave a "T" Art. 376

Extra per ogni foro calibrato (tolleranza F7)

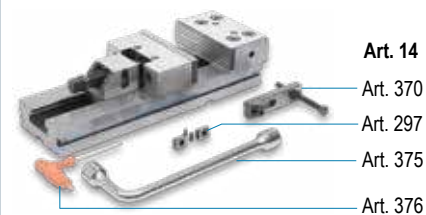
Standard equipment:

- 1 workstop Art. 370
- 1 pair of positioning key-nuts Art. 297
(Standard for 16 mm slot. Other dimensions available on request without price change)
- 1 box wrench Art. 375 ■ 1 T-wrench Art. 376

Extra charge for each calibrated hole (F7 tolerance)

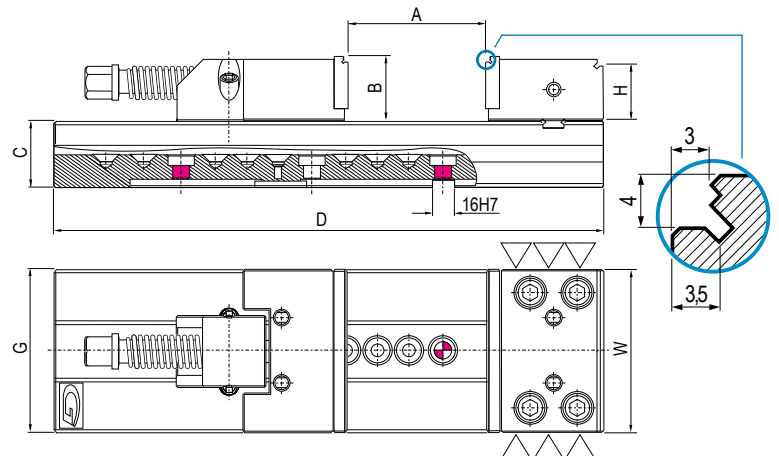

 Vedi gruppo 4 per gamma completa accessori
 See group 4 for complete range of accessories

5 40 kN					6 40 kN						
200	300	400	500	600	200	300	400	500	600	700	800
		170						195			
		65						80			
		70						78			
495	595	695	795	895	535	635	735	835	935	1035	1135
		170						195			
62	67	72	77	82	88	98	108	118	128	138	148
1.15.52000	1.15.53000	1.15.54000	1.15.55000	1.15.56000	1.15.62000	1.15.63000	1.15.64000	1.15.65000	1.15.66000	1.15.67000	1.15.68000

UPGRADE YOUR VISE APPLICATIONS THROUGH MODULAR ACCESSORIES !

Art. 313R	4.31.3R500		4.31.3R600
	53		68
Art. 247	1.65.57200		1.65.67200
Art. 218	2.21.85000		2.21.86000
Art. 247G	1.24.7G500		1.24.7G600
Art. 271	2.27.15000		2.27.16000
Art. 391	4.39.15000		4.39.16000
Art. 392	4.39.25000		4.39.26000

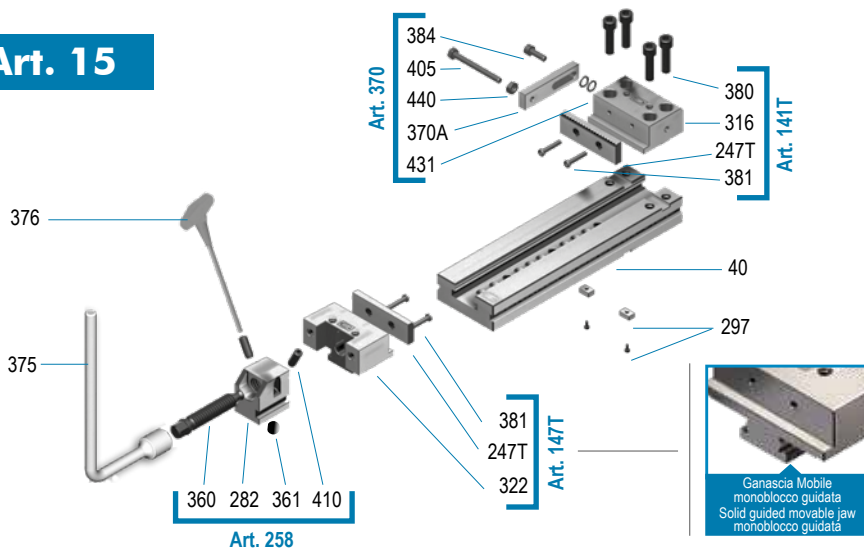
 Pneumo-hydraulic servo units (complete of hydraulic cylinder + support) for multiple clamping *simultaneous* or *independent*, from 2 to 6 vises. See from page 4.38 to 4.49

Art. 15

Art.	Pag.
40	1.22
247T	4.11
282	4.34
297	4.33
316	4.28
322	4.28
360	4.34
361	4.34
370A	4.33
375	4.33
376	4.33

Art.	Pag.
380	4.26
381	4.26
384	4.26
405	4.33
410	4.34
431	4.26
440	4.26
-	-
-	-
-	-
-	-

MORSE e CUBI serie StandardFLEX

StandardFLEX series VISES and CUBES

La Morsa più Evoluta! Dotata del geniale sistema a pettine per la rapida sostituzione delle piastre ganasce discendenti

The Most Recent Vise! Innovative comb system for quick pull-down jaw plate change

Le morsa **GERARDI** della serie **Standardflex** sono un'evoluzione della morsa Standard STD. La loro caratteristica principale è la sostituzione rapida delle piastre ganasce che avviene manualmente e senza l'ausilio di alcun utensile, questo è possibile grazie al sistema Perno-molla, che consente un diverso utilizzo della morsa in tempi ridottissimi. Grazie al sistema a Pettine di rigatura prismatica delle piastre ganascia, risulta migliorato anche l'effetto discendente che durante la fase di serraggio, trascina il pezzo contro lo slittone garantendo anche una notevolissima precisione di riposizionamento.

The **GERARDI** vises of the StandardFLEX series are an evolution of the Standard vise series. Their main characteristic is the quickest jaw plate hand substitution without any tool. This is possible thanks to the new design with pin with spring which increases the standard vise versatility while the prismatic grooves allow a perfect repositioning accuracy (within microns!!!).

1 ALTISSIMA RIPETIBILITÀ DI POSIZIONAMENTO

con particolari perfettamente in squadra

1 HIGHEST REPOSITIONING ACCURACY

with perfect square workpieces.

2 RICONFIGURAZIONE RAPIDISSIMA

grazie alla piastra ganascia intercambiabile manualmente

2 GREAT SAVINGS IN VISE RESETTING TIMES

thanks to the manual interchangeable quick jaw plate

3 EFFETTO DISCENDENTE

Effetto discendente amplificato e migliorato e migliore protezione dai trucioli grazie al sistema a pettine

3 PULL DOWN ACTION

Increased and better pull down action and better protection from chips thanks to the comb system

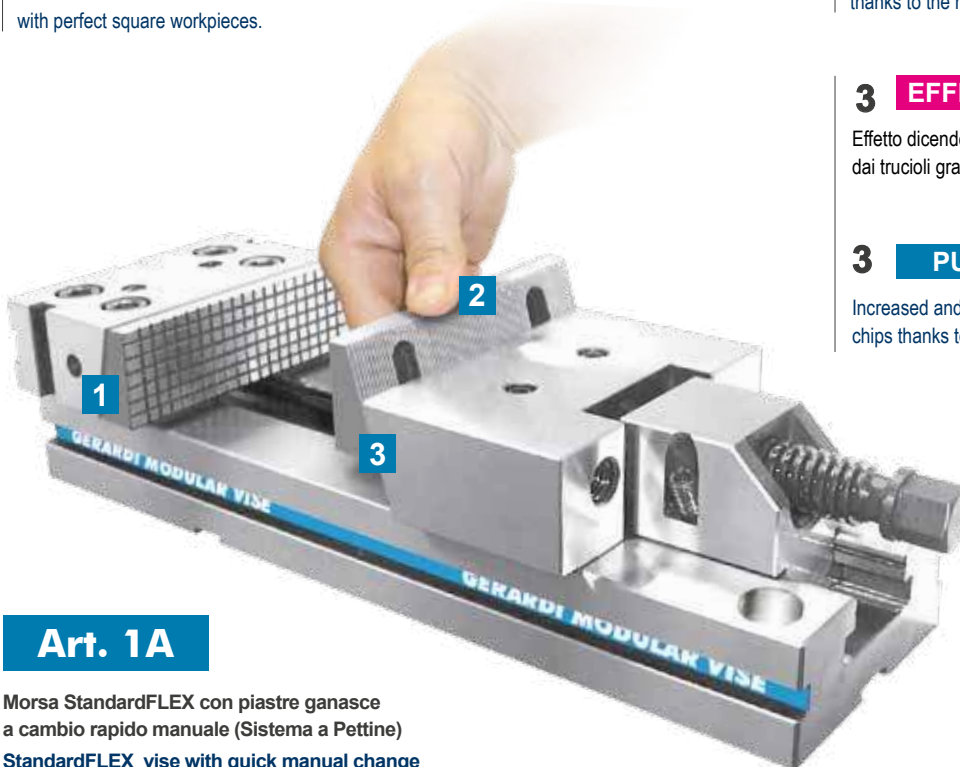

Art. 1A

Morsa StandardFLEX con piastre ganasce a cambio rapido manuale (Sistema a Pettine)
 StandardFLEX vise with quick manual change jaw plates (Comb system)

CARATTERISTICHE E VANTAGGI

- USURA INESISTENTE
- RAPIDITA' DEI SERRAGGI
- MODULARITA' & VERSATILITA'
- PRECISIONI $\pm 0,02$ mm
- RIGIDITA' & SICUREZZA
- DESIGN COMPATTO E MANEGGEVOLEZZA

Si rimanda a quanto esposto a pag. 1.4 e 1.5 (morse serie STANDARD)

TECHNICAL FEATURES and ADVANTAGES

- NO WEAR
- QUICK CLAMPING
- MODULARITY & VERSATILITY
- HIGHEST ACCURACIES $\pm 0,02$ mm
- RIGIDITY & SAFETY
- SPACE SAVING DESIGN & HANDY

See pag. 1.4 and 1.5 (STANDARD series vises)

PIASTRE GANASCE DISCENDENTI INTERCAMBIABILI MANUALMENTE

PULL DOWN JAW PLATES INTERCHANGEABLE by HAND

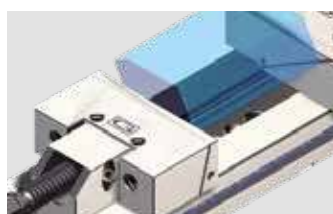
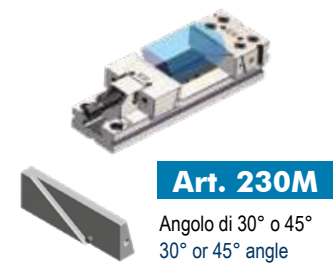
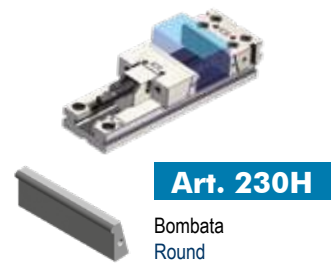
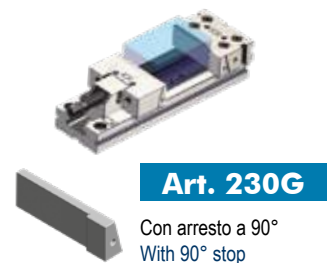
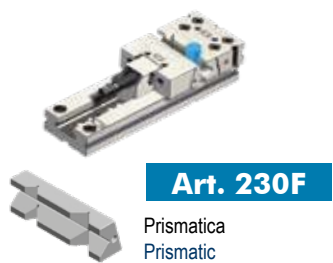
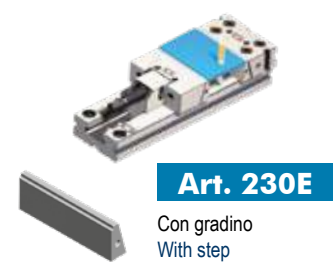
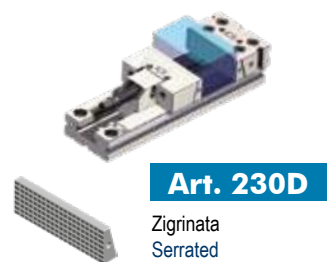
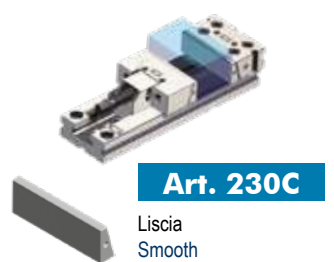
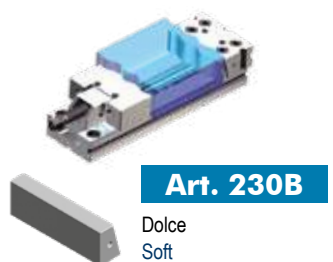

PORTAPIASTRE / THE RACK

Completo di piastre ganasce a cambio rapido a gradino Art.230E
 Complete of quick change step jaw plates Art.230E

Vedi Pag. 4.19 - See Page.4.19

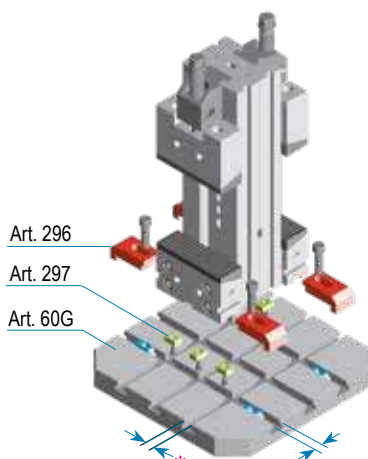

* Cava / T slot = 16 mm

Ancoraggio e posizionamento con staffe e chiavette
 Positioning and clamping through vise clamps

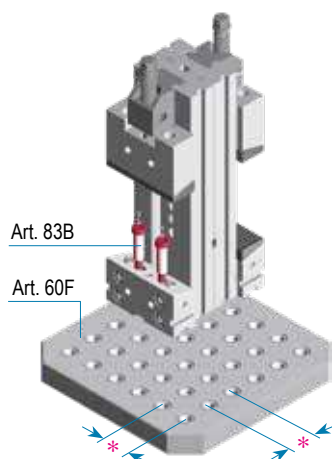

* Passo / Pitch = 50 mm

Ancoraggio e posizionamento a reticolo
 Grid clamping and positioning

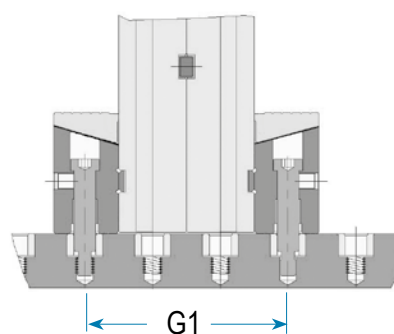

Tipo morsa Vise type	3	4	5	6
G1 mm	150	200	250	

Esempio di montaggio in verticale di 2 morsa
 StandardFLEX contrapposte su piani a reticolo
 Ø 16 mm. Passo 50 mm

Example of version mounting of 2 StandardFLEX vises back
 to back on grid base Ø 16 mm. 50 mm Pitch

Tipo (grandezza) morsa / Vise type (size)	kN	1		2		3		4	
		16 kN	25 kN	30 kN	30 kN	30 kN	30 kN	30 kN	30 kN
Apertura massima / Maximum spread	A	100	150	200	300	200	300	400	500
Art. 1A	W	96	121	146		171			
	B	28	38	48		58			
	C	35	40	50		58			
	D	270	345	420	520	455	555	655	755
	G	75	95	125		145			
	kg	6.8	12.9	25.5	29	37	42	47	52
	Cod.	1.1A.10000	1.1A.20000	1.1A.32000	1.1A.33000	1.1A.42000	1.1A.43000	1.1A.44000	1.1A.45000

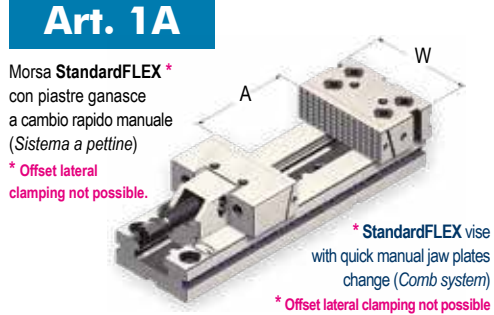
AMPLIA LE TUE APPLICAZIONI TRAMITE GLI ACCESSORI MODULARI !

Art. 230E	Cod.	4.23.0E101	4.23.0E201	4.23.0E301	4.23.0E401
Piastra ganasce intercambiabile Interchangeable jaw plate					
Vedi pagina 4.20 per altezze disponibili See page 4.20 for available height					
	H	23	33	43	53
	H1	5	5	5	5

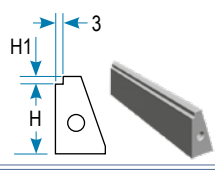

Art. 212	Cod.	1.21.21000	1.21.22000	1.21.23000	1.21.24000
Ganascia mobile intermedia (da usare con Art. 230E) Intermediate movable jaw (to be used with Art. 230E)					

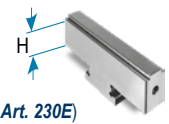

Art. 230B	Cod.	4.23.0B101	4.23.0B201	4.23.0B301	4.23.0B401
Piastra ganasce intercambiabile dolce Soft interchangeable jaw plate					

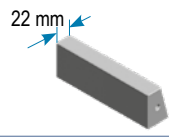

Art. 230F	Cod.	4.23.0F101	4.23.0F201	4.23.0F301	4.23.0F401
Piastra ganasce intercambiabile prismatica Prismatic interchangeable jaw plate					



Art. 271	Art. 391	Cod.	4.39.11000	4.39.12000	4.39.13000	4.39.14000
	CNC / CNC					
	Art. 392	Cod.	4.39.21000	4.39.22000	4.39.23000	4.39.24000
	Pneumatico / Air control					

 Servocomandi oleopneumatici (completi di 1 cilindro e supporto) per serraggi multipli **contemporanei** o **indipendenti**, da 2 a 6 morse. Vedi da pag. 4.38 a 4.49

- Dotazione standard:**
- 1 arresto laterale Art. 370
 - 1 coppia di tasselli di posizionamento Art. 297 (Standard per cava da 16 mm; altre dimensioni a richiesta senza variazione di prezzo)
 - 2 tappi Art. 291 ■ 1 chiave a pipa Art. 375 ■ 1 chiave a "T" Art. 376
- Fori rettificati e calibrati con tolleranza F7 già inclusi nel prezzo

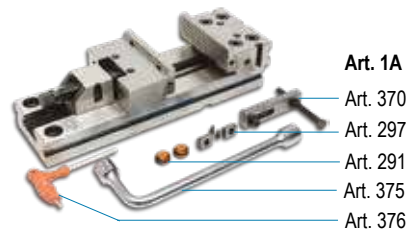



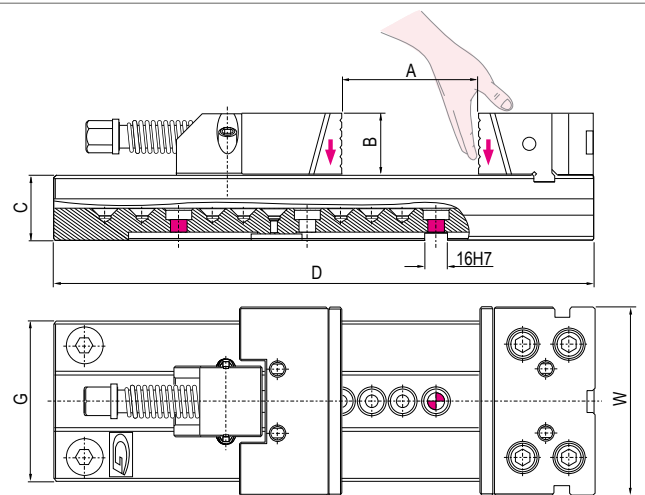

- Standard equipment:**
- 1 workstop Art. 370
 - 1 pair of positioning key-nuts Art. 297 (Standard for 16 mm slot. Other dimensions available on request without price change)
 - 2 inserts Art. 291 ■ 1 box wrench Art. 375 ■ 1 T-wrench Art. 376
- Ground calibrated holes F7 tolerance already included in the price

 Vedi gruppo 4 per gamma completa accessori
 See group 4 for complete range of accessories

5 40 kN					6 40 kN						
200	300	400	500	600	200	300	400	500	600	700	800
		196						296			
		63						78			
		70						78			
495	595	695	795	895	535	635	735	835	935	1035	1135
		170						195			
64	69	74	79	84	95	105	115	125	135	145	155
1.1A.52000	1.1A.53000	1.1A.54000	1.1A.55000	1.1A.56000	1.1A.62000	1.1A.63000	1.1A.64000	1.1A.65000	1.1A.66000	1.1A.67000	1.1A.68000

UPGRADE YOUR VISE APPLICATIONS THROUGH MODULAR ACCESSORIES !

	4.23.0E501		4.23.0E601
Art. 230E			
H	53		68
H1	10		10
	1.21.25000		1.21.26000
Art. 212			
	4.23.0B501		4.23.0B601
Art. 230B			
	4.23.0F501		4.23.0F601
Art. 230F			
	4.39.15000		4.39.16000
Art. 391			
	4.39.25000		4.39.26000
Art. 392			

 Pneumo-hydraulic servo units (complete of hydraulic cylinder + support) for multiple clamping *simultaneous* or *independent*, from 2 to 6 vises. See from page 4.38 to 4.49

Art. 1A

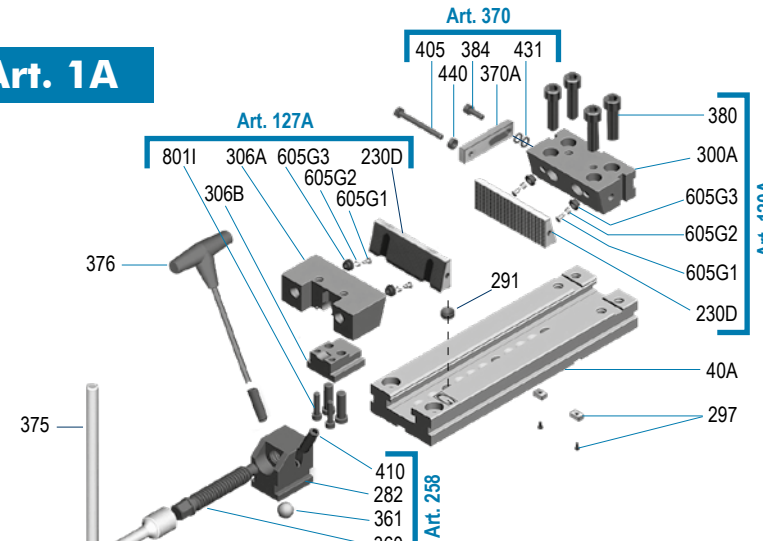

Art. 127A: 801I, 306A, 605G3, 230D, 306B, 605G2, 605G1

Art. 370: 405, 384, 431, 440, 370A

Art. 120A: 380, 300A, 605G3, 605G2, 605G1, 230D, 291

Art. 288: 410, 282, 361, 360

Other labels: 376, 375, 297, 40A

Art.	Pag.	Art.	Pag.
40A	1.22	376	4.33
230D	4.19	380	4.26
282	4.34	384	4.26
291	4.33	405	4.33
297	4.33	410	4.34
300A	4.28	431	4.26
306A	4.28	440	4.26
306B	4.28	605G1	4.20
360	4.34	605G2	4.20
361	4.34	605G3	4.20
370A	4.33	801I	5.61
375	4.33	-	-

Tipo (grandezza) morsa / Vise type (size)	kN	1		2		3		4	
		16 kN	25 kN	30 kN	30 kN	30 kN	30 kN	30 kN	
Apertura massima / Maximum spread	A	100	150	200	300	200	300	400	500
Art. 1AZ	W	96	121	146		171			
	B	28	38	48		58			
	C	35	40	50		58			
	D	270	345	420	520	455	555	655	755
	G	75	95	125		145			
	kg	7.3	13.2	26.2	29.7	37.9	43	48.1	53.2
	Cod.	1.1A.Z1000	1.1A.Z2000	1.1A.Z3200	1.1A.Z3300	1.1A.Z4200	1.1A.Z4300	1.1A.Z4400	1.1A.Z4500

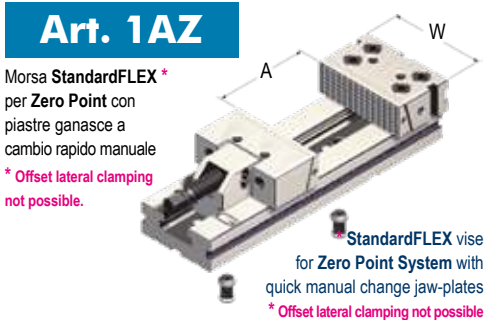
AMPLIA LE TUE APPLICAZIONI TRAMITE GLI ACCESSORI MODULARI !

Art. 230E	Cod.	4.23.0E101		4.23.0E201		4.23.0E301		4.23.0E401	
		H	23	33	43		53		
H1	5	5	5		5				

Art. 212	Cod.	1.21.21000		1.21.22000		1.21.23000		1.21.24000	
		H	23	33	43		53		

Art. 230B	Cod.	4.23.0B101		4.23.0B201		4.23.0B301		4.23.0B401	
		H	23	33	43		53		

Art. 230F	Cod.	4.23.0F101		4.23.0F201		4.23.0F301		4.23.0F401	
		H	23	33	43		53		

Art. 271	Cod.	4.39.11000		4.39.12000		4.39.13000		4.39.14000	
		Art. 403	4.39.21000	4.39.22000	4.39.23000		4.39.24000		

 Servocomandi oleopneumatici (completi di 1 cilindro e supporto) per serraggi multipli **contemporanei** o **indipendenti**, da 2 a 6 morse. Vedi da pag. 4.38 a 4.49

- Dotazione standard:**
- 1 arresto laterale Art. 370
 - 2 tiranti Art. 10A
 - 2 tappi Art. 291
 - 1 chiave a pipa Art. 375 ■ 1 chiave a "T" Art. 376

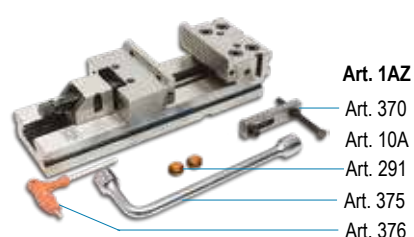

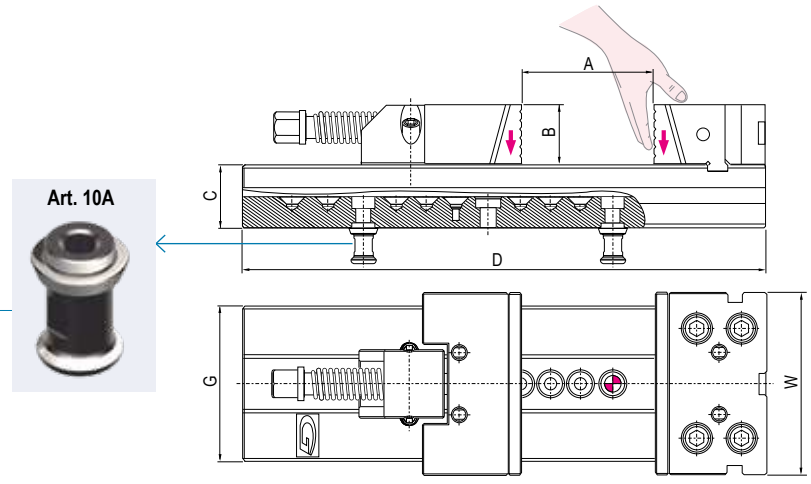

- Standard equipment:**
- 1 workshop Art. 370
 - 2 pullstuds Art. 10A
 - 2 inserts Art. 291
 - 1 box wrench Art. 375 ■ 1 T-wrench Art. 376

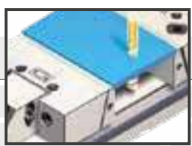
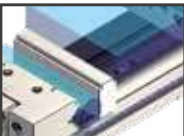

 Vedi gruppo 4 per gamma completa accessori
 See group 4 for complete range of accessories

5 40 kN					6 40 kN						
200	300	400	500	600	200	300	400	500	600	700	800
		196						296			
		63						78			
		70						78			
495	595	695	795	895	535	635	735	835	935	1035	1135
		200						300			
65.3	70.3	75.3	80.3	85.3	97	107	117	127	137	147	157
1.1A.Z5200	1.1A.Z5300	1.1A.Z5400	1.1A.Z5500	1.1A.Z5600	1.1A.Z6200	1.1A.Z6300	1.1A.Z6400	1.1A.Z6500	1.1A.Z6600	1.1A.Z6700	1.1A.Z6800

UPGRADE YOUR VISE APPLICATIONS THROUGH MODULAR ACCESSORIES !

	4.23.0E501		4.23.0E601
Art. 230E			
H	53		68
H1	10		10
	1.21.25000		1.21.26000
Art. 212			
	4.23.0B501		4.23.0B601
Art. 230B			
	4.23.0F501		4.23.0F601
Art. 230F			
	4.39.15000		4.39.16000
Art. 391			
	4.39.25000		4.39.26000
Art. 392			

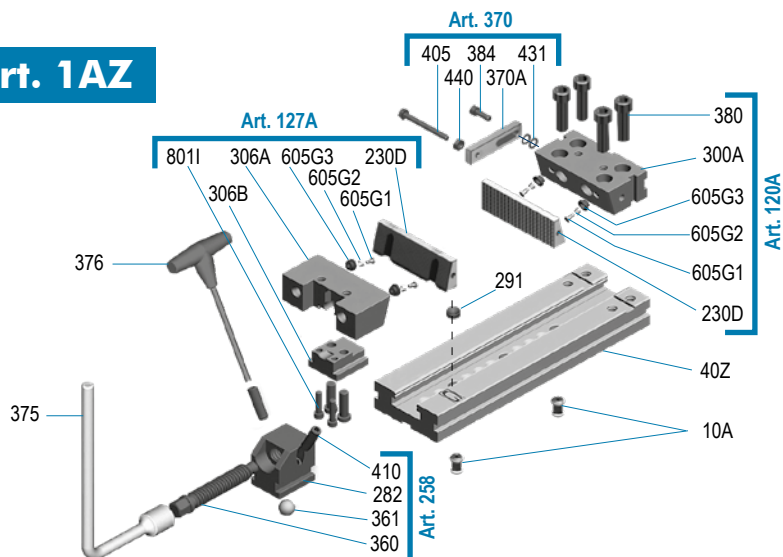
 Pneumo-hydraulic servo units (complete of hydraulic cylinder + support) for multiple clamping *simultaneous* or *independent*, from 2 to 6 vises. See from page 4.38 to 4.49

Art. 1AZ

Art.	Pag.
10A	9.31
40Z	1.22
230D	4.19
282	4.34
291	4.33
300A	4.28
306A	4.28
306B	4.28
360	4.34
361	4.34
370A	4.33
375	4.33

Art.	Pag.
376	4.33
380	4.26
384	4.26
405	4.33
410	4.34
431	4.26
440	4.26
605G1	4.20
605G2	4.20
605G3	4.20
801I	5.61
-	-

Tipo (grandezza) morsa / Vise type (size)
Art. 40

 Slittone base
 serie **STD** senza
 alcuna dotazione

 Vise base
STD series
 supplied without any accessory

	1	2	3		4			
C	35	40	50		58			
D	270	345	420	520	455	555	655	755
G	75	95	125		145			
K	-	-	100		100			
N	2	3	3	4	3	4	5	6
U	111	111	122,5		129			
Z	100	100	100		100			
kg	3,8	7,3	15,1	18,7	20,6	25,2	29,7	34,5
Cod.	1.80.10270	1.80.20345	1.80.30420	1.80.30520	1.80.40455	1.80.40555	1.80.40655	1.80.40755

Art. 40A

 Slittone base serie
StandardFLEX
 senza alcuna dotazione

 Vise base
StandardFLEX series
 supplied without any accessory

kg	3,8	7,3	15,1	18,7	20,6	25,2	29,7	34,5
Cod.	1.40.A1000	1.40.A2000	1.40.A3200	1.40.A3300	1.40.A4200	1.40.A4300	1.40.A4400	1.40.A4500

Art. 40Z

 Slittone base
 serie **Zero Point**
 senza alcuna dotazione

 Vise base
Zero Point series
 supplied without any accessory

ZZ	200	200	200	200	200	200	300	300
kg	4	8	15,5	19	21	25,5	30	35
Cod.	1.40.Z1000	1.40.Z2000	1.40.Z3200	1.40.Z3300	1.40.Z4200	1.40.Z4300	1.40.Z4400	1.40.Z4500

PIASTRE D'INTERFACCIA Art.62 per morse STD
CONNECTING PLATES Art.62 for STD vises
Art. 62
STD

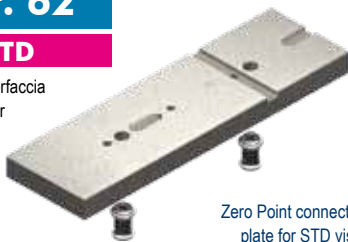
 Piastra di interfaccia
 Zero Point per
 morsa STD

 Zero Point connecting
 plate for STD vises

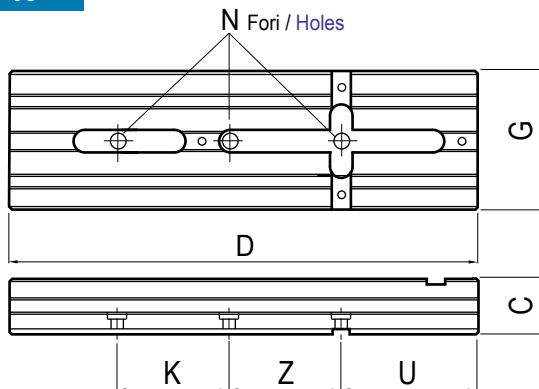
C1	28	28	33		33			
UU	86	86	97,5	97,5	104	104	104	104
ZZ	200	200	200	200/250	200	200/250	250/300	250/300
kg	4,5	7,2	13,5	16,7	17	20,8	24,4	28,2
Cod.	1.62.11000	1.62.21500	1.62.32000	1.62.33000	1.62.42000	1.62.43000	1.62.44000	1.62.45000

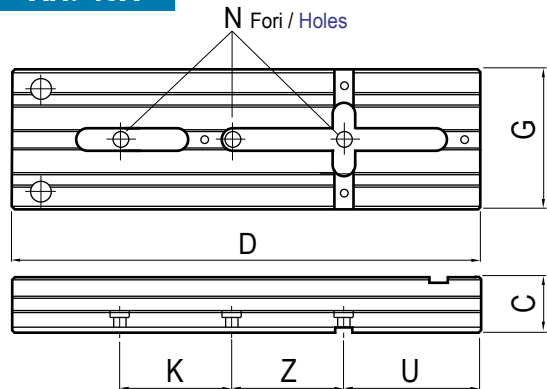
Art. 40

 Versione normale: Cave da 16 mm (H7)
 Normal version: 16 mm slots (H7)

Art. 40A

 Versione normale: Cave da 16H7 e fori calibrati Ø8F7 (t.1) - Ø16F7 (t.2-3-4-5-6)
 Normal version: 16H7 slot and calibrated holes Ø8F7 (t.1) - Ø16F7 (t.2-3-4-5-6)

5					6						
70					78						
495	595	695	795	895	535	635	735	835	935	1035	1135
170					195						
100					100						
2	3	4	5	6	4	5	6	7	8	9	10
145					152						
100					100						
32,6	39,2	45,8	52,5	59	47	56	65	74	83	61	100
1.80.50495	1.80.50595	1.80.50695	1.80.50795	1.80.50895	1.80.60535	1.80.60635	1.80.60735	1.80.60835	1.80.60935	1.80.60035	1.80.60135

32,6	39,2	45,8	52,5	59	47	56	65	74	83	91	100
1.40.A5200	1.40.A5300	1.40.A5400	1.40.A5500	1.40.A5600	1.40.A6200	1.40.A6300	1.40.A6400	1.40.A6500	1.40.A6600	1.40.A6700	1.40.A6800

200	200	300	300	300	300	300	300	300	300	300x2	300x2
33	40	46	53	59	47	56	65	74	83	91	100
1.40.Z5200	1.40.Z5300	1.40.Z5400	1.40.Z5500	1.40.Z5600	1.40.Z6200	1.40.Z6300	1.40.Z6400	1.40.Z6500	1.40.Z6600	1.40.Z6700	1.40.Z6800

PIASTRE D'INTERFACCIA Art.62 per morse STD

CONNECTING PLATES Art.62 for STD vises

38					38						
120					127						
200	200/250	250/300	250/300	300	250/300	250/300	300	300	300	300	300
25	30	35	40	45	31	36,7	42,5	48,3	54	59,8	65,6
1.62.52000	1.62.53000	1.62.54000	1.62.55000	1.62.56000	1.62.62000	1.62.63000	1.62.64000	1.62.65000	1.62.66000	1.62.67000	1.62.68000

Art. 40Z

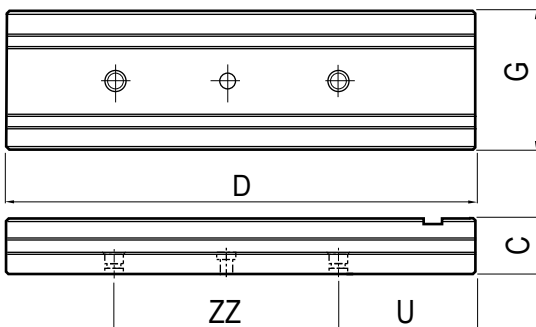

Versione normale: 2 o 3 fori filettati per tiranti Art. 10A
 Normal version: 2-3 holes threaded for pull studs Art. 10A

Art. 62

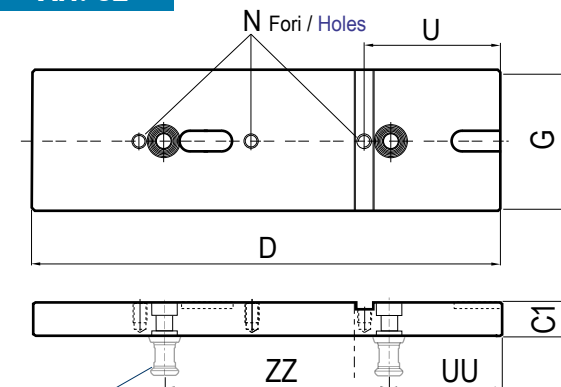

Art. 10A

Tiranti Art. 10A non in dotazione
 Pull studs Art. 10A not included in the standard equipment

Tipo (grandezza) morsa / Vise type (size)		1	2	3	4				
Tolleranza / Tolerance									
- 0,02	C	35	40	50	58				
-	D	270	345	420	520	455	555	655	755
- 0,02	F	10	12	13	15				
+ 0,02	F1	10	10	12	18				
- 0,02	G	75	95	125	145				
+ 0,02	Y	21	28	41	51				
-	Y1	31	41	57	70				
-	M	M10	M12	M14	M16				
-	N	76	76	84,5	89				
-	N1	35	35	38	40				
-	O	32	32	36	36				
-	P	19	19	20	22				
-	Q	50	62	88	100				
-	T	9,5	9,5	11,5	11,5				
-	T1	15	15	20	20				
-	T2	5	5	7	7				
-	U	111	111	122,5	129				
-	K	-	-	100	100				
-	Z	100	100	100	100				

Art. 40

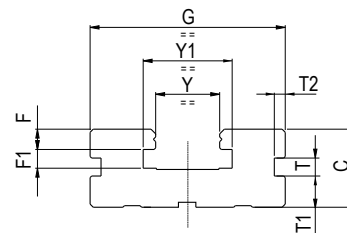
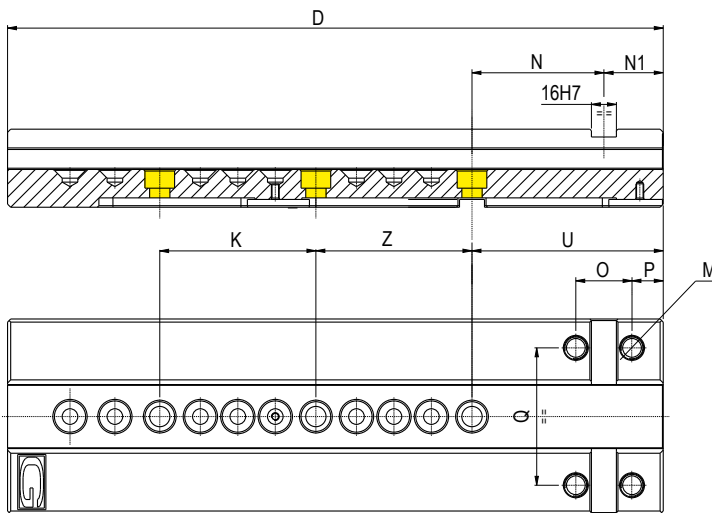
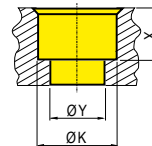
 Slittone base serie **STD** / Vise base **STD** series

Dettaglio foro per vite TCEI / TCEI screw hole details

Type	1	2	3	4	5	6
X	4,5	5,5	8	8	17	17
Ø Y	6,5	8,5	13	13	17	17
Ø K	10,5	13,5	19	19	26	26

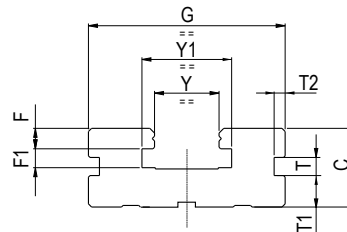
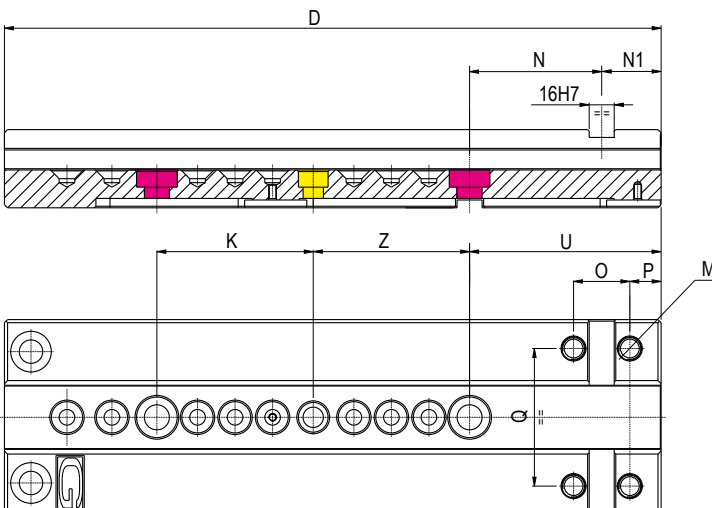
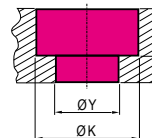
Art. 40A

 Slittone base serie **StandardFLEX** / Vise base **StandardFLEX** series

Dettaglio foro per vite calibrata / Calibrated screw hole details

Type	1	2	3	4	5	6
X	8			11		
Ø Y	16F7			16F7		
Ø K	21			25		

5					6							
		70						78				
495	595	695	795	895	535	635	735	835	935	1035	1135	
		20						20				
		18						18				
		170						195				
		61						71				
		80						91				
		M20						M20				
		100						107				
		45						45				
		44						44				
		23						23				
		120						133				
		17,5						17,5				
		26						26				
		10						10				
		145						152				
		100						100				
		100						100				

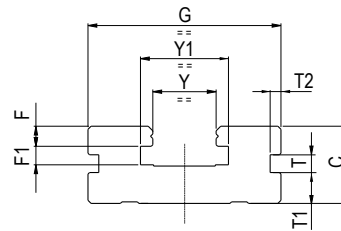
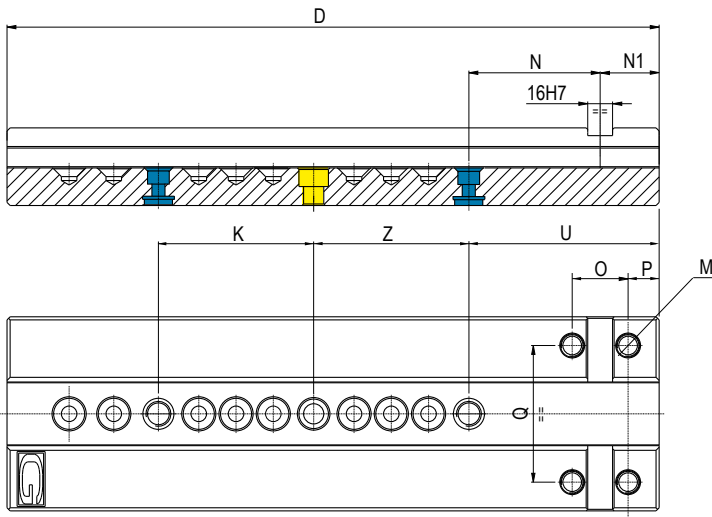
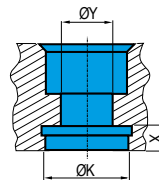
Art. 40Z

 Slittone base serie **ZERO POINT** / Vise base **ZERO POINT** series

Dettaglio foro per Zero Point / Zero Point hole details

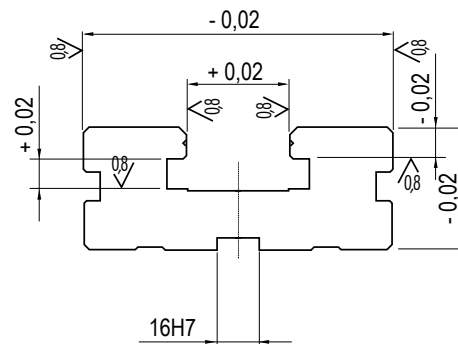
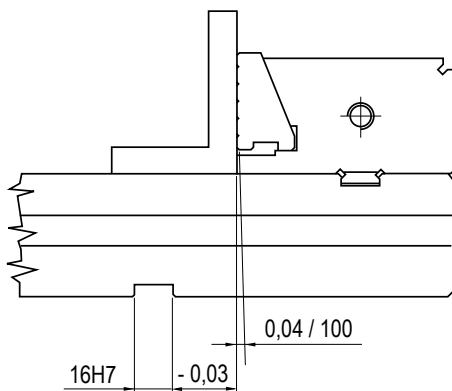
Type	1	2	3	4	5	6
X						6
Ø Y						13
Ø K						20

 Tolleranze generiche per morse **XL** / **XL** vise generic tolerances

Tipo (grandezza) morsa / Vise type (size)

	1	
	kN	16 kN
A	80	130
W	100	
B	30	
D	250	300
E	300	350
G	75	
G1	120	
J	77,9	
L	300	
M	33	
N	85	
kg	37	42
Cod.	3.70.00801	3.70.01301

Art. 700

Cubomorsa modulare standard in **monoblocco**
 Standard modular vise tower in **solid body**

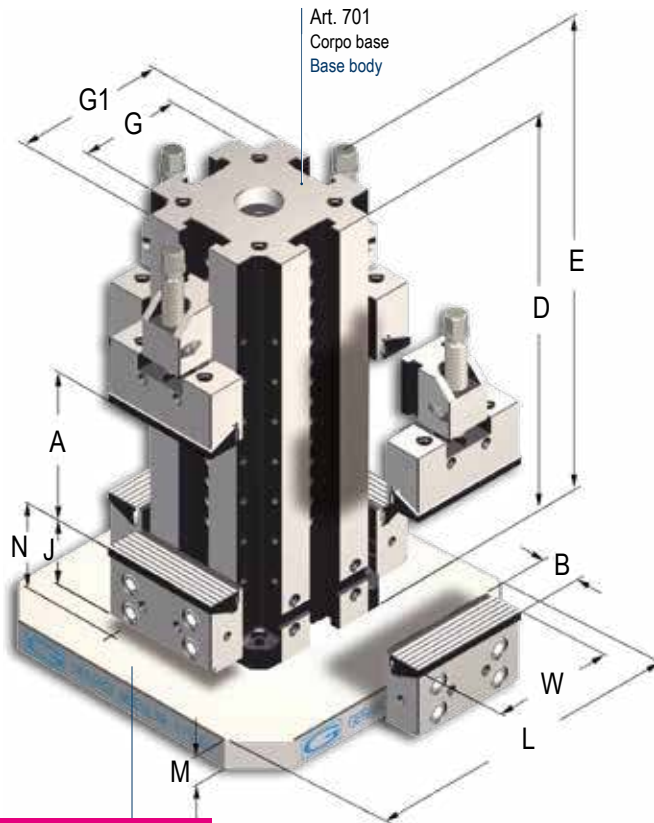
Dotazione standard:

- 4 arresti laterali Art. 370
- 2 coppie di tasselli di posizionamento Art. 297 (Standard per cava da 16 mm; altre dimensioni a richiesta senza variazione di prezzo)
- 1 chiave a pipa Art. 375
- 1 chiave a "T" Art. 376

Standard equipment:

- 4 workstops Art. 370
- 2 pairs of positioning key-nuts Art. 297 (Standard for 16 mm slot; other widths available on request without price change)
- 1 box wrench Art. 375
- 1 "T"- wrench Art. 376

Art. 828 (extra)
Tipo (grandezza) morsa / Vise type (size)

	1	
	kN	16 kN
Apertura massima / Maximum spread	A	100
	D	270 *
	E	320
	P	75 *
kg	10	
Cod.	1.75.01000	

Art. 750

Morse standard montate verticalmente
 N° 4 morse STD Art. 1+ N° 1 Art. 450
 Standard vises vertically mounted
 N° 4 vises STD Art. 1+ N° 1 Art. 450

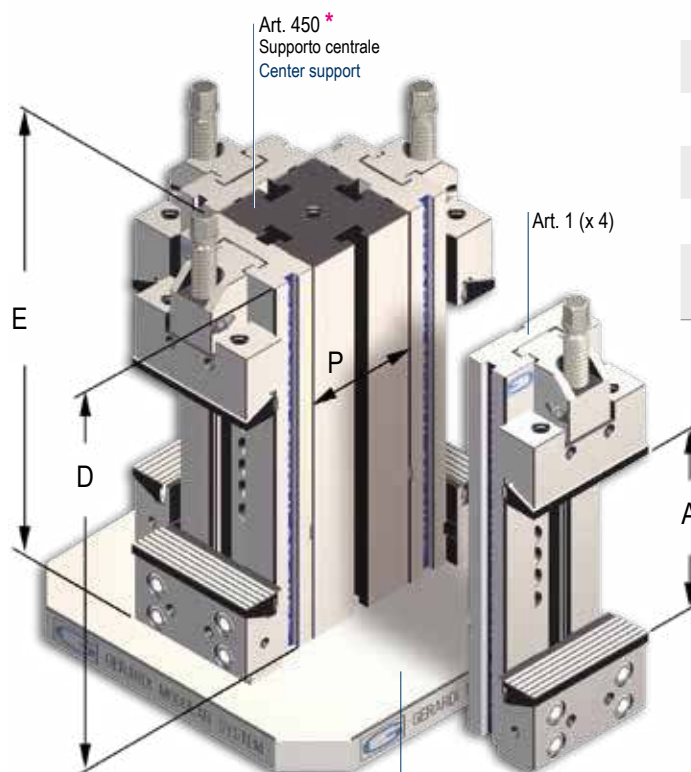
Dotazione standard:

- 4 arresti laterali Art. 370
- 2 coppie di tasselli di posizionamento Art. 297 (Standard per cava da 16 mm; altre dimensioni a richiesta senza variazione di prezzo)
- 1 chiave a pipa Art. 375
- 1 chiave a "T" Art. 376

Standard equipment:

- 4 workstops Art. 370
- 2 pairs of positioning key-nuts Art. 297 (Standard for 16 mm slot; other widths available on request without price change)
- 1 box wrench Art. 375
- 1 "T"- wrench Art. 376

Art. 828 (extra)

2 25 kN		3 30 kN			4 30 kN				5 40 kN	6 40 kN
155	205	170	270	370	145	245	345	445	-	-
125		150			175				200	300
40		50			60				-	-
350	400	400	500	600	400	500	600	700	-	-
430	480	470	570	670	475	575	675	775	-	-
95		125			145				170	195
160		190			230				*	*
77,9		89,4			96,9				*	*
350		400			450				*	*
33		38			38				-	-
85		102			111				-	-
83	96	137	160	183	197	230	263	296	-	-
3.70.01552	3.70.02052	3.70.01803	3.70.02803	3.70.03803	3.70.01454	3.70.02454	3.70.034 54	3.70.04454	-	-

* Altre dimensioni a richiesta / Other dimensions on request

2 25 kN	3 30 kN		4 30 kN				5 40 kN			6 40 kN		
150	200	300	200	300	400	500	200	300	400	300	400	500
345 *	420	520	455	555	655	755	495	595	695	635	735	835
345	450	550	455				-			-		
95 *	125		145				170			195		
19	46		68				98			145		
1.75.02000	1.75.03200	1.75.03300	1.75.04200	1.75.04300	1.75.04400	1.75.04500	1.75.05200	1.75.05300	1.75.05400	1.75.06300	1.75.06400	1.75.06500

* Altre dimensioni a richiesta / Other dimensions on request

Tipo (grandezza) morsa / Vise type (size)

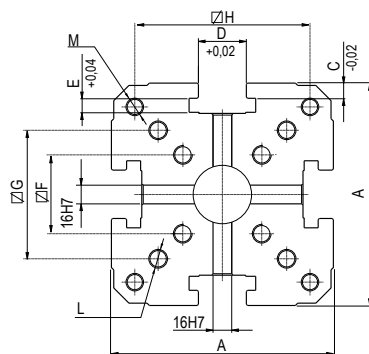

Art. 701

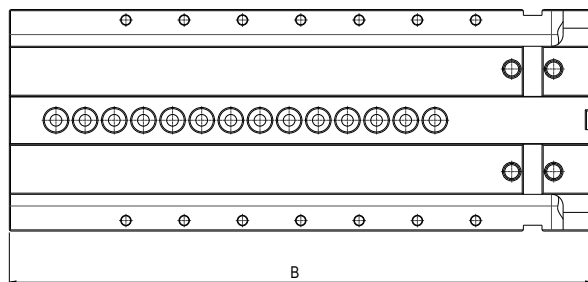

Senza alcuna dotazione
Without accessory equipment

Art. 701

Corpo slittone standard
Body for standard vise tower

Tipo (grandezza) morsa / Vise type (size)

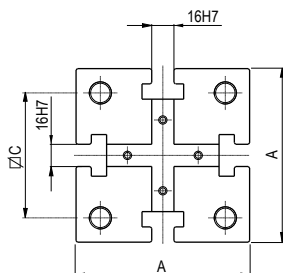

Art. 450



Senza alcuna dotazione
Without accessory equipment

Art. 450

Supporto centrale per montaggio morse modulari standard in verticale. Dolce.
Center support for vertical arrangement of standard modular vises. Soft.

Tipo (grandezza) morsa / Vise type (size)

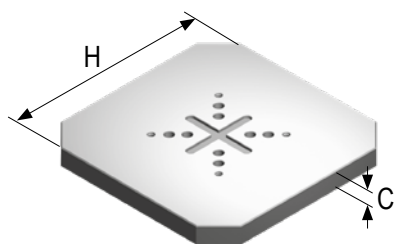

Art. 828

Piastra base per cubo-morsa
Head plate for vise-tower

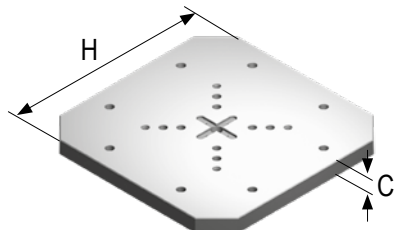

Art. 828A

Piastra base per cubo-morsa personalizzata
(Bussola di centraggio Art. 852 compresa)
Head plate for vise-tower tailor made
(Centering bushing Art. 852 included)

	1		2		3			4				5	6
A	120		160		190			200				*	*
B	250	300	350	400	400	500	600	400	500	600	700	*	*
C	10		12		13			15				20	20
D	21		28		41			51				61	71
E	10		10		12			18				18	18
F	40		54		70			80				80	
G	70		84		110			134				134	
H	-		120		150			200				210	
L	M12		M16		M16			M20				M20	*
M	-		Ø 13		Ø 13			Ø 13				Ø 13	
kg	25	30	64	73	92	115	138	135	168	200	232	*	
Cod.	1.70.10801	1.70.11301	1.70.11552	1.70.12052	1.70.11803	1.70.12803	1.70.10803	1.70.11454	1.70.12454	1.70.13454	1.70.14454	*	

*A richiesta / On request

	1	2	3		4				5			6		
A	75	95	125		145				170			195		
B	270	345	420	520	455	555	655	755	495	595	695	635	735	835
C	50	60	90		110				110			*		
D	M12	M16	M16		M16				M20			*		
kg	10	19	46		68				98			145		
Cod.	1.45.01000	1.45.02000	1.45.03420	1.45.03520	1.45.04455	1.45.04555	1.45.04655	1.45.04755	1.45.05495	1.45.05595	1.45.05695	1.45.06635	1.45.06735	1.45.06835

*A richiesta / On request

	1	2	3	4	5	6	7
C	33	33	38	38	38	38	38
H	300	350	400	450	500	630	800
kg	22,5	30,5	45	57	72	114	183
Cod.	1.82.81000	1.82.82000	1.82.83000	1.82.84000	1.82.85000	1.82.86000	1.82.87000

C	33	33	38	38	38	38	38
H	300	350	400	450	500	630	800
kg	22	30	44,5	56,5	71	113	182
Cod.	1.82.8A100	1.82.8A200	1.82.8A300	1.82.8A400	1.82.8A500	1.82.8A600	1.82.8A700

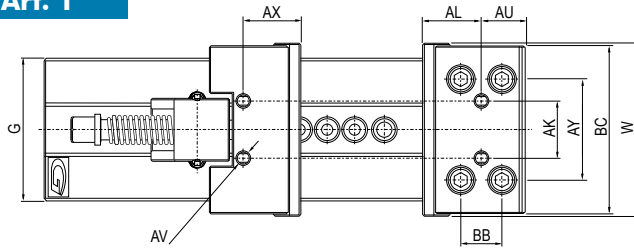
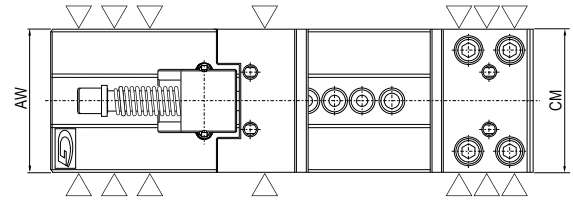
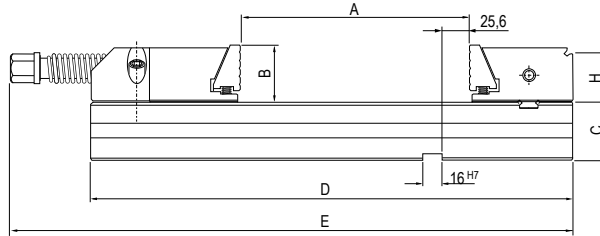
Art. 1

Art. 12

Art. 1+12

Tipo (grandezza) morsa / Vise type (size)

Tabella dimensionale / Table dimension

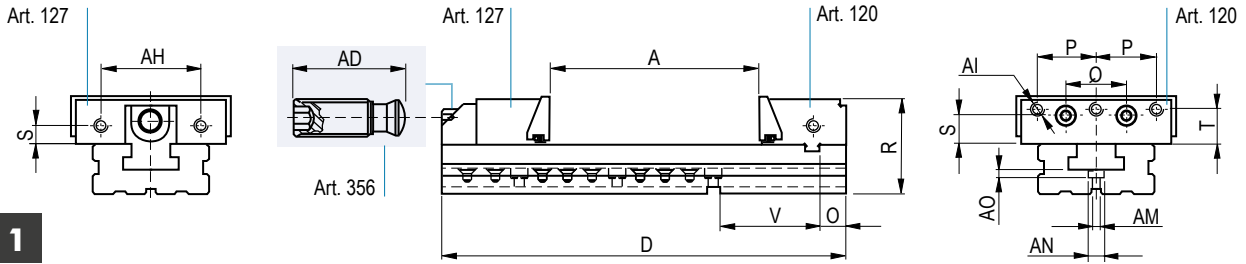
mm	1			2			3			4				5				6					
W	100	125	150	175			200				300												
A	100	150	200	300	200	300	400	500	200	300	400	500	600	200	300	400	500	600	700	800			
B	30	40	50	60				65				80											
C	35	40	50	58				70				78											
D	270	345	420	520	455	555	655	755	495	595	695	795	895	535	635	735	835	935	1035	1135			
E	320	425	500	600	530	630	730	830	580	680	780	880	980	630	730	830	930	1030	1130	1230			
F	225	285	370	470	385	485	585	685	410	510	610	710	810	440	540	640	740	840	940	1040			
G	75	95	125	145				170				195											
H	23	33	43	53				53				68											
I	55	70	110	160	110	160	210	260	105	165	205	265	305	115	165	215	265	315	365	415			
J	34	50	70	104	70	104	137	170	67	107	134	174	200	74	107	140	174	207	240	274			
K	124	174	226	326	226	326	426	526	236	336	436	536	636	236	336	436	536	636	736	836			

mm	1	2	3	4	5	6	Tolleranza Tolerance	mm	1	2	3	4	5	6	Tolleranza Tolerance
L	54	77.9	89.4	96.9	113.4	120.4	- 0.04	AO	4.5	5.5	12.5	12.5	17	17	
M	72.9	72.9	84.4	91.9	108.4	115.4	- 0.04	AP	15	15	20	20	26	26	
N	10	10	12	18	18	18	+ 0.02	AQ	16	18	26	26	29	30	
O	27	27	30	32	37	37	± 0.02	AR	18	24	26	34	31	38	
P	38	50	62	72.5	83	120		AS	11	17	17	17	21	21	
R	65	80	100	118	135	158		AT	11	11	13	13	13	17	
S	18	23	29	37.5	37.5	47.5		AU	35.5	35.5	38.5	41.5	47	47	
T	16	20.5	27.5	36.5	34	46		AV	M8	M10	M12	M12	M16	M16	
U	111	111	122.5	129	145	152		AX	20	23	28	28	34	38	
V	76	76	84.5	89	100	107	± 0.02	AY	50	62	88	100	120	133	
W	-	-	100	100	100	100		AZ	M10	M12	M14	M16	M20	M20	
X	20	25	25	25	33.33	33.33		BB	32	32	36	36	44	44	
Y	21	28	41	51	61	71	+ 0.02	BC	96	121	146	171	196	296	
Z	100	100	100	100	100	100		BG	28	38	48	58	63	78	
AA	10	12	13	15	20	20	- 0.02	BJ	50	60	80	90	100	120	
AB	25.6	25.6	25.6	25.6	25.6	25.6	+ 0.02	BL	180	225	290	320	370	400	
AC	31	41	57	70	80	90		BM	9.5	9.5	11.5	11.5	17.5	17.5	
AD	53	73	81	101	113	135		CC	77	77	88.5	96	112	117	
AF	13	18	18	18	18	18		CD	48	58	78	88	98	117	
AG	M10	M16	M16	M16	M20	M20		CE	5	5	5	5	5	5	
AH	62	80	90	116	138	184		CF	-	-	64	64	71	-	
AI	M10	M10	M12	M12	M12	M12		CG	-	-	100	100	128	-	
AJ	14	19	24	29	31.5	39		CH	5.5	8	11	17	17	24	
AK	38	38	50	50	76	240		CI	24.5	32	39	43	48	56	
AX	25,6	42,4	50,1	55,4	66,4	73,4		CJ	12	12	13	13	18	18	
AL	42.4	42.4	50.9	55.4	66.4	73.4		-	-	-	-	-	-	-	
AM	4.5	5.5	12.5	12.5	17	17		-	-	-	-	-	-	-	
AN	10	13	19	19	25	25									



1

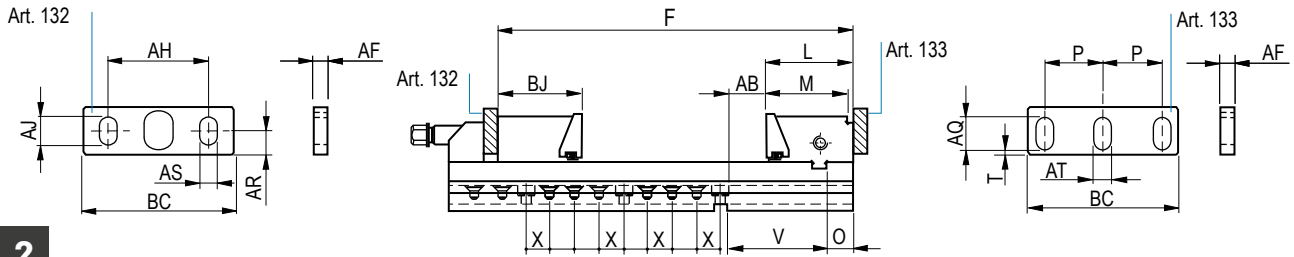

2

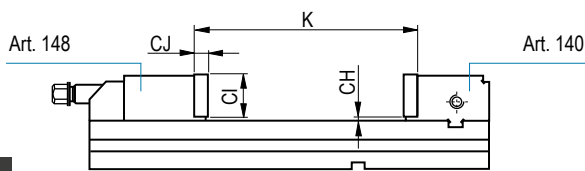

3

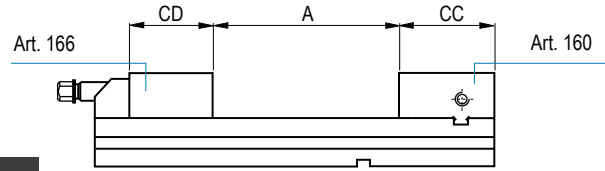

4

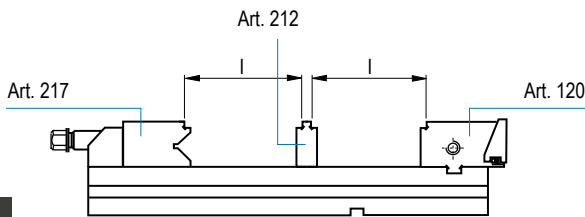

5

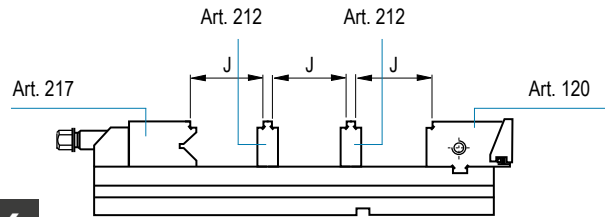

6

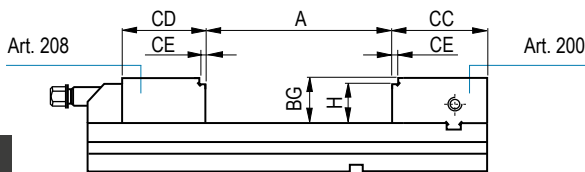

7

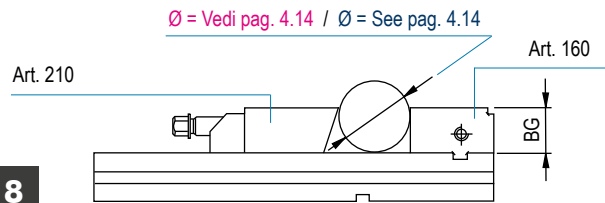

8

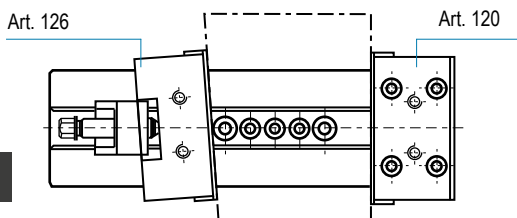

9

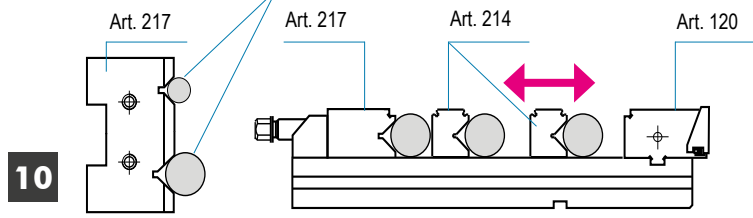

10

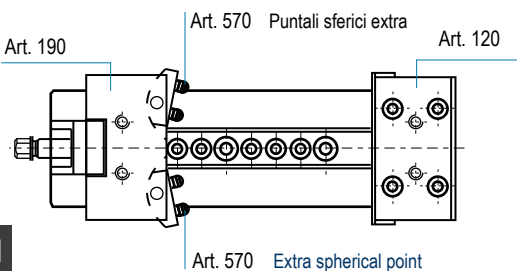

11

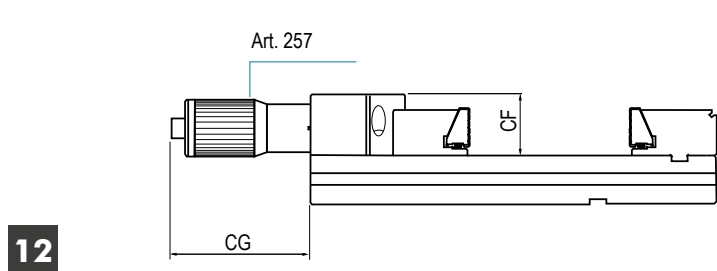

12

Tipo (grandezza) morsa / Vise type (size)	1	2	3	4	5	6
Ganascia piana sovrapponibile fissa o mobile Straight stack-type jaw fixed or movable Art. 130* Art. 130S* <i>Extra large / Extra width</i>						
	Cod. Art. 130 2.13.01000 2.13.02000 2.13.03000 2.13.04000 2.13.05000 2.13.06000 Cod. Art. 130S 2.13.0S100 2.13.0S200 2.13.0S300 2.13.0S400 2.13.0S500 2.13.0S600 Cad / Each					
Ganascia sovrapponibile per pezzi tondi fissa o mobile Stack-type jaw round parts fixed or movable Art. 131* Art. 131S* <i>Larghezza normale / Normal width</i>						
	Cod. Art. 131 2.13.11000 2.13.12000 2.13.13000 2.13.14000 2.13.15000 2.13.16000 Cod. Art. 131A 2.13.1A100 2.13.1A200 2.13.1A300 2.13.1A400 2.13.1A500 2.13.1A600 Cod. Art. 131S 2.13.1S100 2.13.1S200 2.13.1S300 2.13.1S400 2.13.1S500 2.13.1S600 Cod. Art. 131AS 2.13.1AS10 2.13.1AS20 2.13.1AS30 2.13.1AS40 2.13.1AS50 2.13.1AS60 Cad / Each					
Ganascia piana sovrapponibile fissa o mobile Straight stack-type jaw fixed or movable Art. 136* Art. 136S* <i>Larghezza normale / Normal width</i>						
	Cod. Art. 136 2.13.61000 2.13.62000 2.13.63000 2.13.64000 2.13.65000 2.13.66000 Cod. Art. 137 2.13.71000 2.13.72000 2.13.73000 2.13.74000 2.13.75000 2.13.76000 Cod. Art. 136S 2.13.6S100 2.13.6S200 2.13.6S300 2.13.6S400 2.13.6S500 2.13.6S600 Cod. Art. 137S 2.13.7S100 2.13.7S200 2.13.7S300 2.13.7S400 2.13.7S500 2.13.7S600 Cad / Each					
Ganascia a squadra sovrapponibile fissa o mobile Square stack-type jaw fixed or movable Art. 138* Art. 138S* <i>Larghezza normale / Normal width</i>						
	Cod. Art. 138 2.13.81000 2.13.82000 2.13.83000 2.13.84000 2.13.85000 2.13.86000 Cod. Art. 139 2.13.91000 2.13.92000 2.13.93000 2.13.94000 2.13.95000 2.13.96000 Cod. Art. 138S 2.13.8S100 2.13.8S200 2.13.8S300 2.13.8S400 2.13.8S500 2.13.8S600 Cod. Art. 139S 2.13.9S100 2.13.9S200 2.13.9S300 2.13.9S400 2.13.9S500 2.13.9S600 Cad / Each					
Ganascia a squadra sovrapponibile doppia Double square jaw stack-type Art. 138D* Art. 138DS* <i>Larghezza normale / Normal width</i>						
	Cod. Art. 138D 2.13.8D100 2.13.8D200 2.13.8D300 2.13.8D400 2.13.8D500 2.13.8D600 Cod. Art. 139D 2.13.9D100 2.13.9D200 2.13.9D300 2.13.9D400 2.13.9D500 2.13.9D600 Cod. Art. 138DS 2.13.8DS10 2.13.8DS20 2.13.8DS30 2.13.8DS40 2.13.8DS50 2.13.8DS60 Cod. Art. 139DS 2.13.9DS10 2.13.9DS20 2.13.9DS30 2.13.9DS40 2.13.9DS50 2.13.9DS60 Cad / Each					
Ganascia prismatica sovrapponibile fissa o mobile Stack-type prismatic jaw fixed or movable Art. 150* Art. 150S* <i>Larghezza normale / Normal width</i>						
	Cod. Art. 150 1.15.01000 1.15.02000 1.15.03000 1.15.04000 1.15.05000 1.15.06000 Cod. Art. 150A 1.15.0A100 1.15.0A200 1.15.0A300 1.15.0A400 1.15.0A500 1.15.0A600 Cod. Art. 150S 1.15.0S100 1.15.0S200 1.15.0S300 1.15.0S400 1.15.0S500 1.15.0S600 Cod. Art. 150AS 1.15.0AS10 1.15.0AS20 1.15.0AS30 1.15.0AS40 1.15.0AS50 1.15.0AS60 Cad / Each					

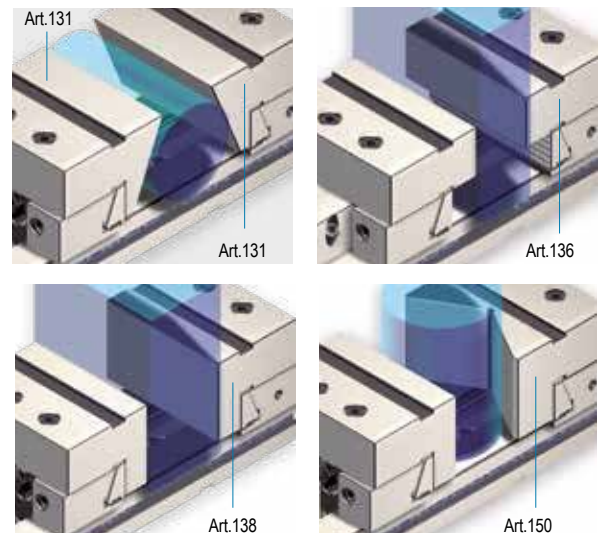
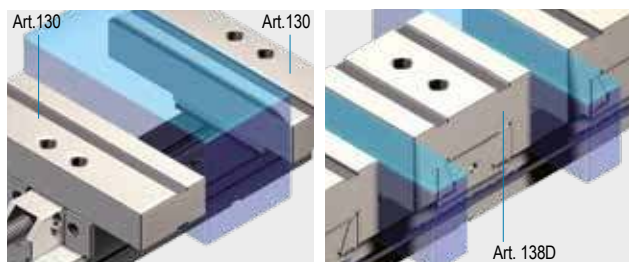
Versione "S" in acciaio lavorabile / "S" type in soft steel
Esempi applicativi - Application examples:

Tipo (grandezza) morsa / Vise type (size)
Art. 130

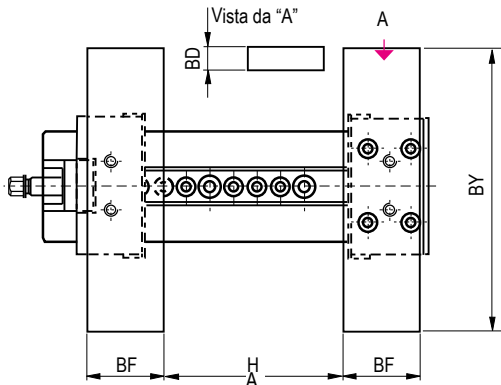
 Temprate o in acciaio lavorabile
 Hardened or soft

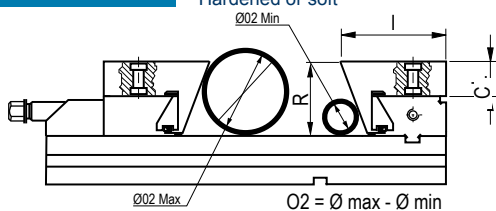
Art. 131/131A

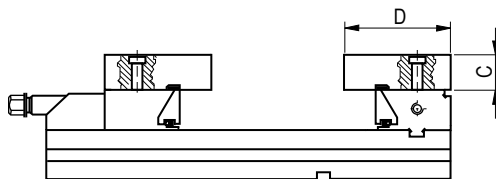
 Temprate o in acciaio lavorabile
 Hardened or soft

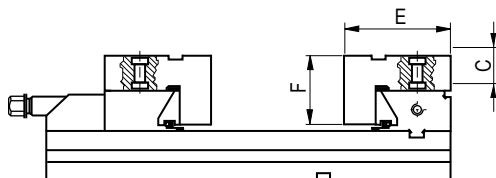
Art. 136/137

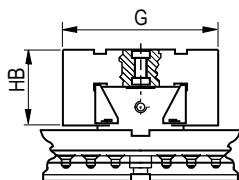
 Temprate o in acciaio lavorabile
 Hardened or soft

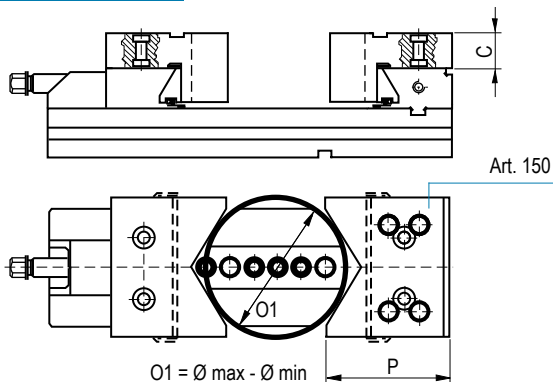
Art. 138/139

 Temprate o in acciaio lavorabile
 Hardened or soft

Art. 138D/139D

 Temprate o in acciaio lavorabile
 Hardened or soft

Art. 150/150A

 Temprate o in acciaio lavorabile
 Hardened or soft

mm	1	2	3	4	5	6
C	32	42	52	62	67	82
D	84	84	105	130	130	150
E	80	88	105	110	130	135
F	57	70	90	110	128	150
G	110	110	162	171	192,8	190
I	95	95	123	136	170	206
BD	32	42	52	62	72	82
BF	80	84	105	120	128	135
BY	200	250	300	350	400	600
P	84	120	120	140	175	206
R	60	78	90	110	128	150
Art. 150						
Ø1 min	26	32	38	45	55	75
Ø1 max	160	200	240	280	360	500
W	96	121	146	171	196	296
W2	74	94	124	144	169	194
Q	30	30	30	30	30	30
Art. 131						
Ø2 min	33	43	49	60	70	
Ø2 max	75	100	130	160	180	220

ISTRUZIONI PER UN CORRETTO UTILIZZO

INSTRUCTIONS FOR A PROPER USE

POSIZIONAMENTO

Le morsa della serie **STANDARD** e **STANDARDFLEX** possono essere posizionate orizzontalmente oppure in verticale sulla tavola della macchina o su sovratavola.

Il **posizionamento** e l'**allineamento** avviene tramite chiavette a 16 H7. Si può anche allineare la morsa tramite viti calibrate, garantendo tolleranze centesimali. (No per tipo 1e2).



Tavola macchina con cave a "T"
Machine table with T-slots

POSITIONING

STANDARD and **STANDARDFLEX** series vises can be aligned on the machine table horizontally or vertically mounted.

Accurate **positioning** and **alignment** within centesimal tolerances is made through 16 H7 longitudinal or crossway keys. It is also possible to align the vise through calibrated ground screws (Not for types 1 and 2).

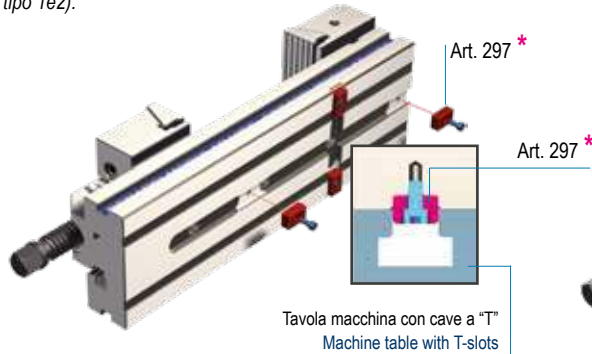

Tavola macchina con reticolo
Machine table grid type

* La dotazione standard comprende 1 sola coppia di tasselli di posizionamento Art. 297
 * Standard equipment includes only 1 pair of positioning key nuts Art. 297

CONTROLLO ALLINEAMENTO TRA CAVA TRASVERSALE E GANASCIA FISSA.

Posizionare la morsa verticalmente assicurandosi che sia perfettamente parallela al piano di appoggio **A** nei due sensi. Successivamente, con un comparatore centesimale, controllare il parallelismo del piano cava e della ganascia fissa.

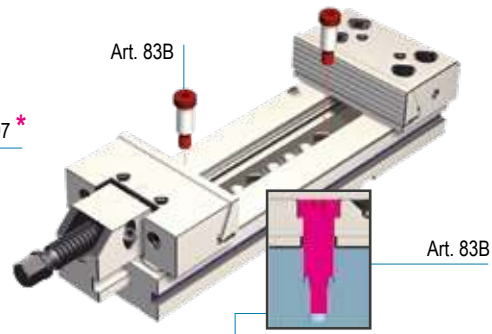
ALIGNMENT BETWEEN THE CROSS KEYWAY AND THE FIXED JAW PLATE

Set the vise vertically ensuring that it is perfectly parallel to the table **A** in both sides. Then with an indicator check the parallelism of the keyway and its alignment with the fixed jaw plate.

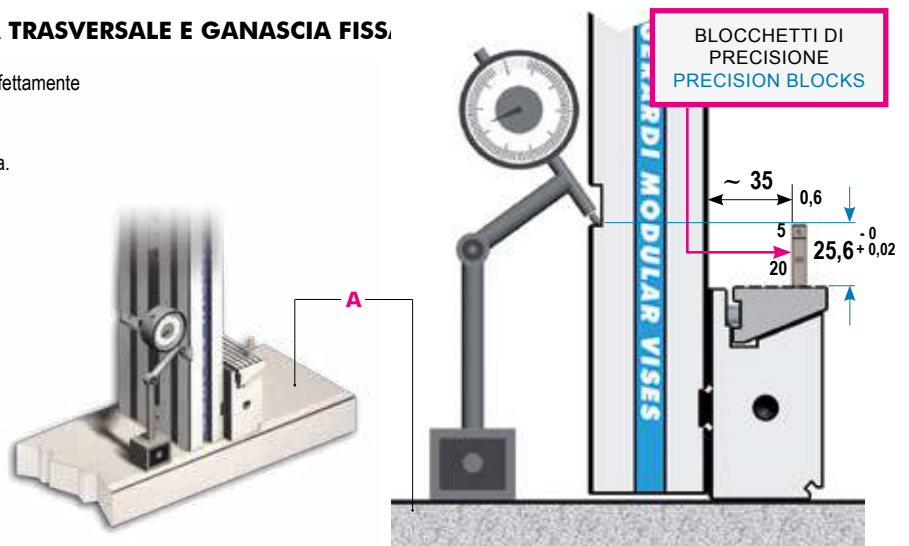

ANCORAGGIO

L'**ancoraggio** può avvenire tramite viti centrali o staffe laterali. La scelta più valida rimane comunque il **fissaggio tramite staffe laterali** (Art. 296). Due morsa parallele allineate tramite chiavetta centrale, viti calibrate o riferimenti laterali, mantengono lo stesso riferimento sulle ganasce fisse con tolleranza pari a **0,02 mm**.

WISE CLAMPING ON THE MACHINE TABLE

The **clamping** on the machine table can be made through screws from the central groove or through side clamps.

The **best clamping choice is through side clamps** (Art. 296).

Two vises aligned through central cross keys or ground screws or side lateral reference points guarantee the same reference and alignment on the fixed jaw section with accuracy within **0,02 mm**.

Lo staffaggio della morsa con questo metodo **NON è consigliabile** perché la sua quota X può flettere e compromettere lo scorrimento della ganascia mobile su questo asse

Hard tightening down of the vise to the machine table by this method is **NOT recommended** as it can distort gap X and prevent the moving jaw from sliding

Per morsa tipo 3, forza consigliata massima 50 Nm per vite

Suggested max torque 50 Nm each screw for type 3 vise

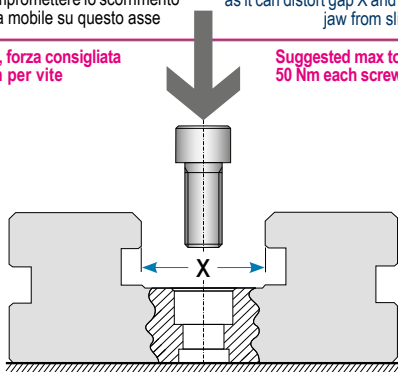

IL METODO CORRETTO È QUESTO

THIS IS THE RIGHT WAY

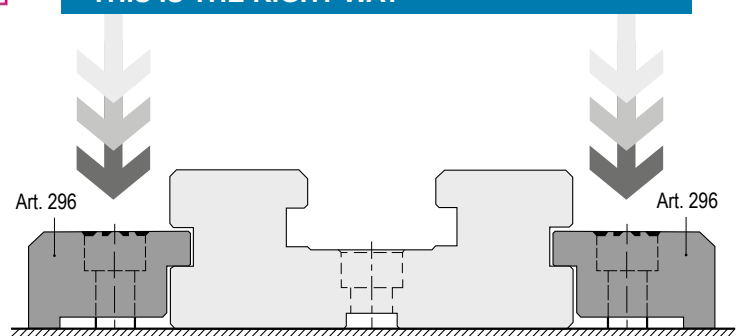

ISTRUZIONE PER UN CORRETTO UTILIZZO

INSTRUCTIONS FOR A PROPER USE

OPERAZIONI PER UN CORRETTO SERRAGGIO DEI PEZZI

Le illustrazioni si riferiscono all' Art. 1 "STANDARD"

1- Assicurarsi che la morsa sia correttamente posizionata e ancorata alla tavola della macchina e che la ganaschia fissa Art. 120 / 120A sia correttamente fissata. (Fig. 1)



Fig.1 | Pic.1

ACTIONS FOR THE BEST WORK-PIECE CLAMPING

Pictures refer to Art. 1 "STANDARD" vise

1- Ensure that the vise is properly positioned and clamped to the machine table and that the fixed jaw Art.120 / 120A is properly assembled. (Pic.1)

2- Posizionare la ganaschia mobile Art. 127 / 127A allentando i due grani Art. 410 per consentire il sollevamento della sfera calibrata Art. 361 e quindi lo spostamento di tutto il gruppo di serraggio Art. 258 in una posizione più idonea sullo slittone di base, lasciando circa 5 mm di aria rispetto al pezzo da serrare. (Fig. 2)

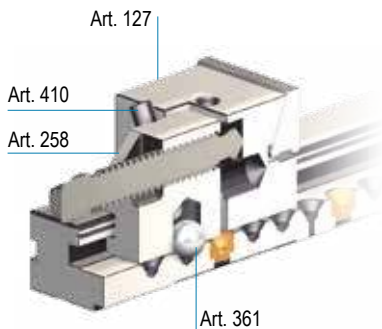

2- Position the movable jaw Art.127 / 127A loosening the 2 set screws Art.410 in order to allow the ground ball Art.361 lift and then move the Art.258 blocking group in the most proper position on the vise base leaving roughly 5 mm space with respect to the workpiece to clamp. (Pic.2)

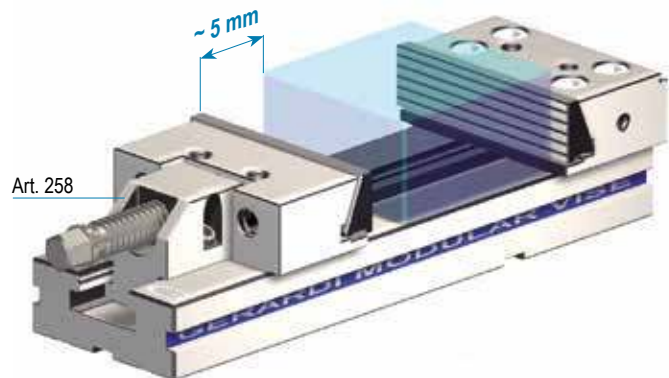
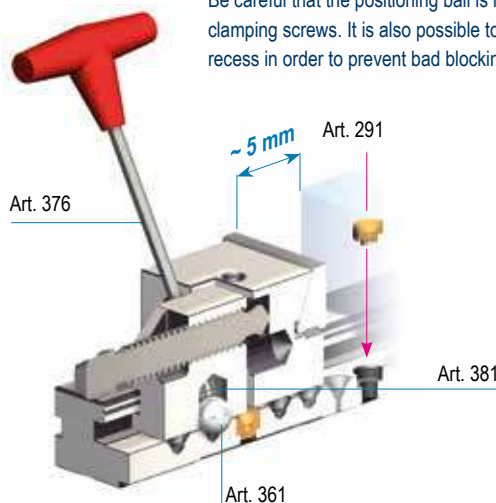

Fig.2 | Pic.2

3- Nello stringere i due grani Art. 410 mediante la chiave Art. 376, (agendo in senso orario) per assicurarsi che la sfera di posizionamento Art. 361, sia correttamente posizionata in una sede sferica.

Fare attenzione che tale sfera non venga posizionata in una incassatura delle viti di ancoraggio. E' possibile posizionare l'apposito inserto Art. 291 con sede sferica per prevenire incastri. (Fig. 3)



3- Tightening the 2 set screws Art.410 through the T-wrench Art.376 to ensure that the positioning ball Art.361 is properly positioned in a spherical recess.

Be careful that the positioning ball is not pushed in the hole used for the vise clamping screws. It is also possible to use a proper insert Art. 291 with spherical recess in order to prevent bad blocking of the ball. (Pic. 3)

Fig.3 | Pic.3

UTILIZZO E MANUTENZIONE DELLE MORSE STD

USE AND MAINTENANCE OF STD VISES

UTILIZZO DELL' OPZIONE "EFFETTO DISCENDENTE"

4- Nel caso di morse Art.1 volendo avvalersi della opzione piastre ganasce discendenti, allentare di 1/4 di giro le viti Art. 381 / 382 (Fig. 4) per permettere alle piastre ganasce discendenti Art. 230 di scorrere dall' alto verso il basso, ottenendo così un serraggio del pezzo verso la base morse.

L' azzeramento e l'allineamento degli assi saranno da eseguire con il particolare da lavorare già serrato

"PULL DOWN" ACTION OPTION

4- Using Art.1 vises, if the pull down option is required, loose of 1/4 of a turn the screws Art.381 / 382 (Pic.4) in order to allow the jaw plates Art.230 to run downward getting a perfect clamping of the workpiece against the vise base. The axis zero setting and the alignment must be done when the workpiece already clamped

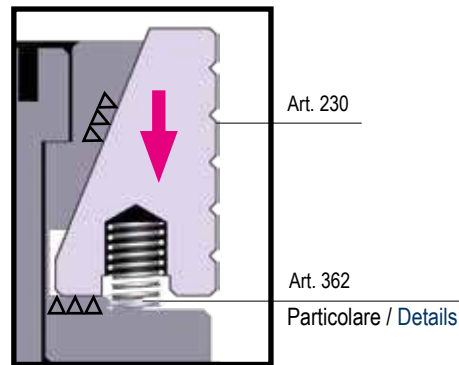
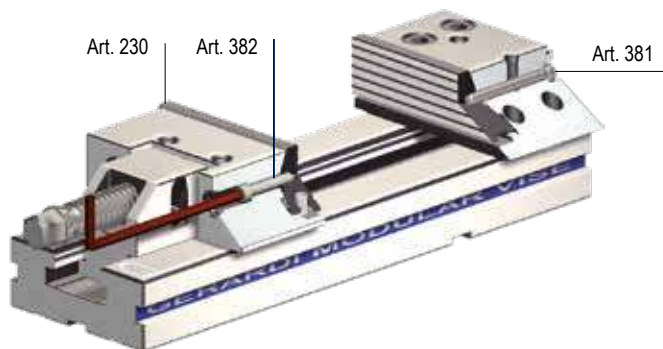

SOLO PER MORSE STANDARD - ONLY FOR STANDARD VISES

Allentando le viti di 1/4 di giro si ha un sollevamento della piastra della ganasca Art. 230 grazie alla spinta della molla Art. 362. Eseguire l'azzeramento mentre con il pezzo serrato

Loosing the screws of 1/4 of a turn you get a jaw plate Art.230 lift because of the spring Art.362 action.

Check alignment with workpiece clamped.



Fig.4 | **Pic.4**

5- Posizionare il pezzo da serrare sullo slittone Art. 40 o 40A e tenerlo contro la ganasca fissa Art. 120 o 120A. Per un corretto posizionamento del pezzo ci si può avvalere dei riferimenti laterali Art. 370. (Fig. 5)

5- Position the workpiece on the vise base Art.40 or 40A and push it against the fixed jaw Art.120 or 120A. For a proper workpiece positioning you can use the work-stop Art.370. (Pic.5)

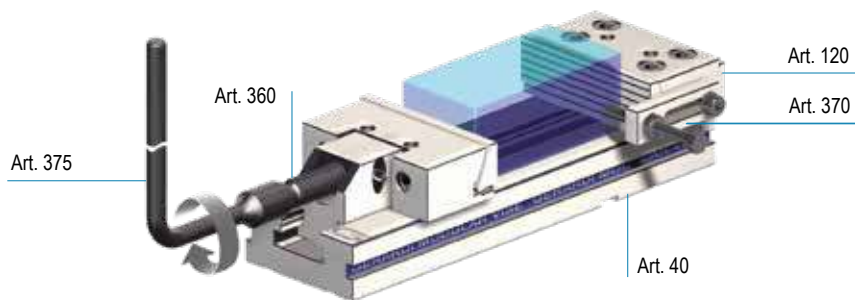

Fig.5 | **Pic.5**

6- Serrare il pezzo agendo in senso orario sulla vite di spinta Art. 360 (Fig. 5) mediante la chiave in dotazione Art. 375 senza utilizzare tubi o martelli. Attenzione: nel serraggio basta 1/4 di giro della chiave dal momento in cui la ganasca tocca il particolare (valori indicativi in tabella). (Fig. 6)

6- Clamp the workpiece turning clockwise the main spindle Art.360 through the box wrench Art.375 without using tubes or hammers. Attention: for the right clamping operation 1/4 of a turn of the box wrench is enough (see table below). (Pic.6)

Valori indicativi delle forze di serraggio raggiunte a 90°
Clamping force indicative values at 90°

Type (Size)	1	2	3	4	5	6
Kn	12	26	36	46	50	50

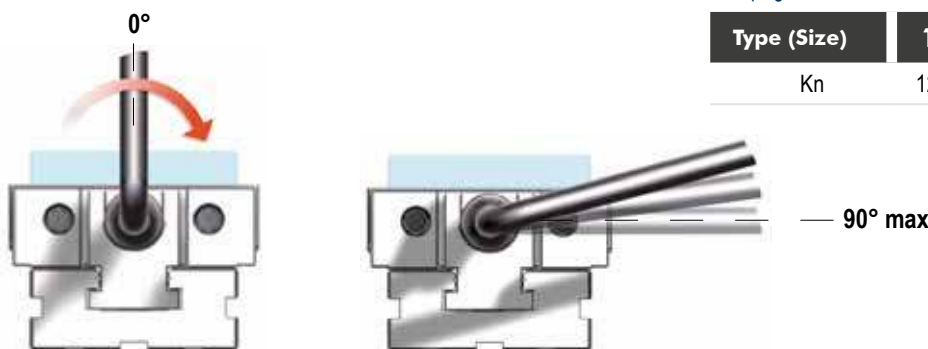

Fig.6 | **Pic.6**

COME SERRARE IL PEZZO

HOW TO CLAMP A WORKPIECE

Per serrare correttamente il pezzo è consigliabile utilizzare una chiave dinamometrica da regolare in base al tipo di morsa e alla forza che si vuole ottenere.

AVVERTENZA

Per una maggior precisione e ripetibilità delle lavorazioni, attenersi alle seguenti disposizioni:

- ❶ Serrare il particolare con una chiave dinamometrica, regolata secondo la tabella "PROVE DI SERRAGGIO".
- ❷ Individuare il momento ideale tramite comparatore posizionato sul pezzo, quindi procedere nelle lavorazioni richieste.
- ❸ Serrare eventuali particolari simili con la medesima forza di serraggio.

In order to clamp the work-piece in the most proper way it is recommended the use of a torque wrench to be adjusted according to the vise type and the clamping power desired or needed.

WARNING

For an increased machining accuracy and repetability use the following instructions:

- ❶ Clamp the workpiece with a torque wrench set according to the "CLAMPING TEST" table.
- ❷ Set the right torque through a clock indicator positioned on the workpiece, then proceed with the machining operations.
- ❸ Clamp next similar workpieces with the same clamping power.

PROVE DI SERRAGGIO / CLAMPING TEST Art.1 & Art1A

Eseguite a temperatura ambiente (20°) con chiave dinamometrica
 Test made with 20° temperature with torque wrench

Esempio: con una morsa TIPO 3, applicando con chiave dinamometrica un momento di 60 Nm, si ottiene una forza di serraggio di 25 Kn
Example: with a vise TYPE 3 (jaw width 150 mm), using torque wrench set at 60 Nm, you can get a clamping power of 25 Kn

	Momento applicato Wrench power	Forza di serraggio Clamping Force Nm
1	30	10
	50	16 MAX
2	20	8
	40	16
3 / 4	60	25 MAX
	40	16
5 / 6	60	25
	80	30 MAX
	80	30
	120	40 MAX

TOLLERANZE GEOMETRICHE

GEOMETRIC ACCURACIES

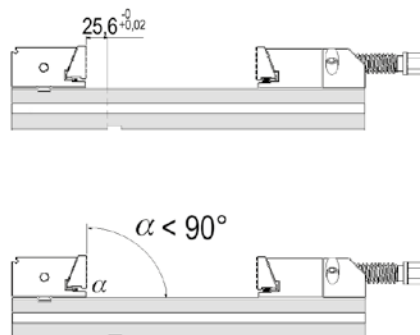
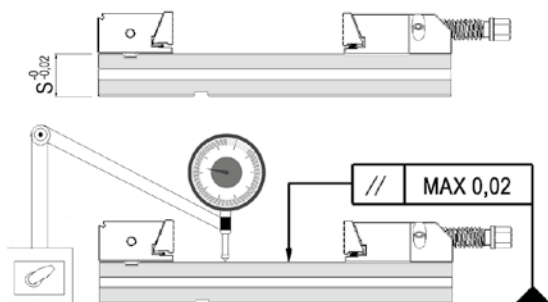

TOLLERANZE DINAMICHE

DYNAMIC ACCURACIES

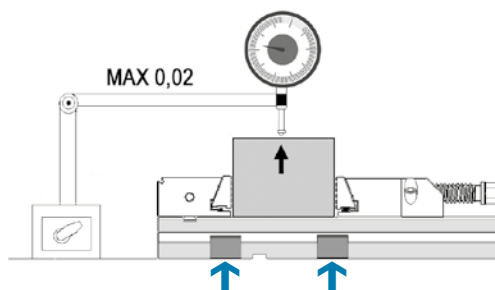
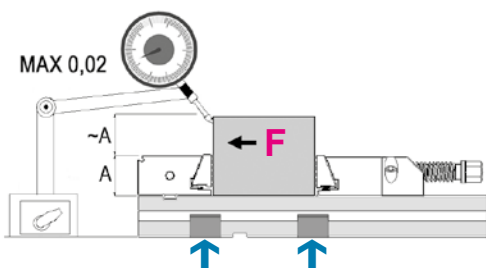

Morsa ancorata con 2 coppie di staffe Art.296 / Vise clamped with n. 2 pairs of Art.296

Valori di flessione nel punto "A" in relazione alle forze di serraggio PER MORSE TIPO 3
 Deflection values at "A" in relation to clamping powers FOR TYPE 3 VISES

Kn	mm
60	0.1
50	0.07
40	0.05
30	0.03
20	0.02
10	0.01
5	0.004
2	0.002

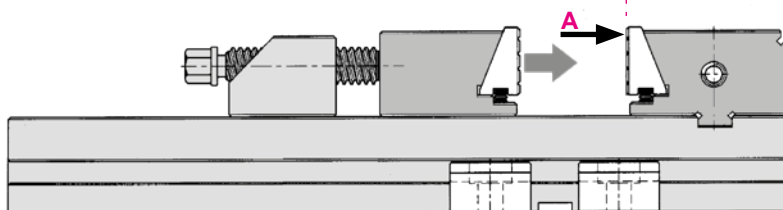

1 kgf . m = 9.806 Nm

DIVISORE AUTOMATICO DPG 250

AUTOMATIC DIVIDING HEAD DPG 250

NEW!
Divisore automatico
 Automatic dividing head

Dati tecnici
 Technical Data

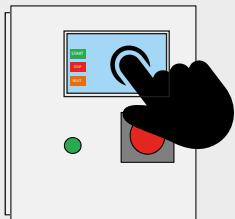
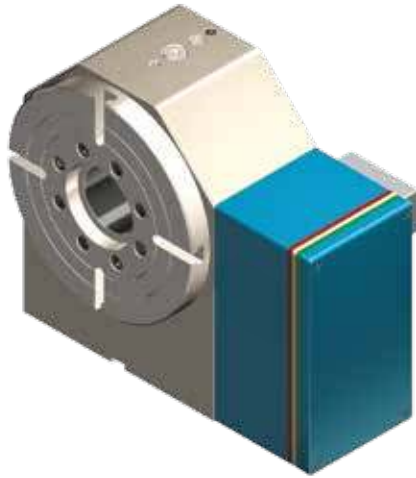
DPG 250

PROGRAMMAZIONE TOUCH SCREEN
 FACILE ED INTUITIVA O TRAMITE COLLEGAMENTO
 DIRETTO AL CNC

EASY AND INTUITIVE TOUCH SCREEN
 PROGRAMMING OR THROUGH DIRECT
 CONNECTION TO THE CNC

- Installazione semplice (alimentazione 220V)
- Corona in bronzo speciale
- Controsupporto semplice
- Vite senza fine in acciaio temprato e rettificato
- Vite e corona in bagno d'olio
- Cuscinetti a vite precaricati
- Cuscinetto anteriore a rulli incrociati sovradimensionato
- Recupero gioco con avvicinamento assiale
- Completa tenuta stagna ai liquidi con possibilità di pressurizzazione
- Possibilità di montare motori di tutte le marche
- Dimensioni esterne contenute
- Finestra di controlli liquidi e condensa
- Lavorazione in posizionamento a 360°

- Easy installation (220V)
- Special bronze crown
- Simple tailstock
- Worm screw in hardened ground steel
- Bath lubrication Screw and Crown
- Pre-loaded screw bearings
- Over-dimensioned crossed-roller front bearing
- Play recover with axial approach
- Watertight seal with possibility of pressurization
- Possibility to mount motors of all brands
- Reduced external dimensions
- Condensation and liquid control window
- 360° work positioning

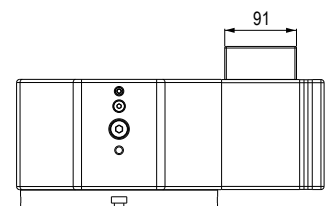
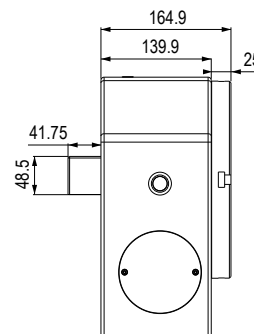
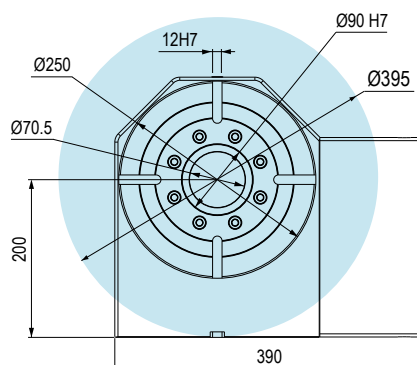
Diametro del divisore Dividing head diameter		250 mm
Diametro del foro passante Clearance hole diameter		70,5 mm
Altezza punta Center height		200 mm
Dimensione della scanalatura a T T-Slot width		12 mm
Sistema di bloccaggio Clamping system		Idrraulico Hydraulic
Forza frenante Clamping torque		3000 Nm
Motore Servo motor		3000 Max.g/min
Minimo incremento Minimum increment		0,002
Velocità di rotazione Rotation speed		33,3 Giri/min
Rapporti vite/corona Speed reduction ratio (screw/gear)		1/90
Rapporti vite/motore Speed reduction ratio (screw/motor)		1/180
Precisione Indexing accuracy		±10 Sec.
Ripetibilità Repeatability		4 Sec.
Max. carico di lavoro sul divisore Max. allowable work weight on the dividing head	Verticale Vertical	Kg.550
	Orizzontale Horizontal	Kg.1500
Max. carico di spinta applicabile sul divisore Max. allowable tool load on the dividing head		N 25000
		FxL Nm 1000
		FxL Nm 2200
Rapporti vite/corona Speed reduction ratio (screw/gear)	Verticale Vertical	10,5 Kg. m ²
Coppia in lavoro Driving torque	Corona dentata Worm gear	698 Nm
Kg		110
Cod.		8.DP.G2500

DPG 250

Tipo (grandezza) morsa / Vise type (size) Montaggio / Mounting		1		2		3		4		
		Double		Double		Double		Double		
Apertura massima / Maximum spread	A	100	150	200	300	200	300	400	500	
Divisore Gerardi DPG250 con morse STD per il serraggio di particolari di tutte le forme e dimensioni.	W	96	121	146		171				
	W1									
	B	28	38	48		58				
	C	35	40	50		58				
	D	270	345	420	520	455	555	655	755	
	G	75	95	125		145				
Gerardi dividing head DPG250 with STD vise for clamping workpieces of all shapes and sizes.										
		Cod.	1.DP.G25000	1.DP.G25010	1.DP.G25020	1.DP.G25030	1.DP.G25040	1.DP.G25050	1.DP.G25060	1.DP.G25070

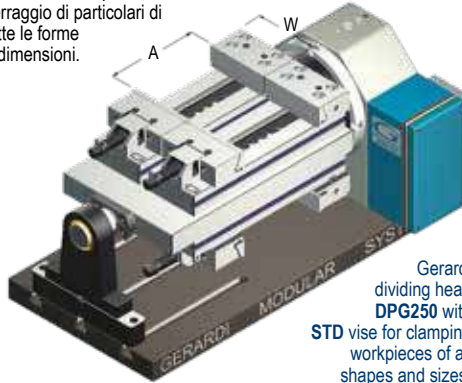

UPGRADE YOUR VISE APPLICATIONS THROUGH MODULAR ACCESSORIES !

Art. 99A
 Supporto
 Support



Cod. 7.99.A1000

Art. 99B
 Perno di centraggio orizzontale
 Horizontal centering pin



Cod. 1.99.B1000

Art. 99H
 Distanziale
 Spacer



Cod. 1.99.H1000

Art. 62
DPG 250
 Piastra di interfaccia DPG 250 per STD
 DPG 250 connecting plate for STD



Cod. 1.62.DPG25

Art. 99T
 Sovratavola per divisore
 Head-plate for dividing head



Cod. 1.99.T1000 1.99.T2000 1.99.T3200 1.99.T3300 1.99.T4200 1.99.T4300 1.99.T4400 1.99.T4500

Art. 99S
 Piastra base con cave
 Piani rettificati
 Base plate with slot
 Faces ground



Cave o fori calibrati su richiesta
 Slot or calibrated holes on request

Dimensioni B mm Dimension B mm	A	C	Kg	Cod.	€
600	400	50	94	7.99.S060S	
750	400	50	117	7.99.S075S	
900	400	50	141	7.99.S090S	
1100	400	50	172	7.99.S110S	

Disponibili quote "B" a step di 50mm - Available dimension "B" in steps of 50mm

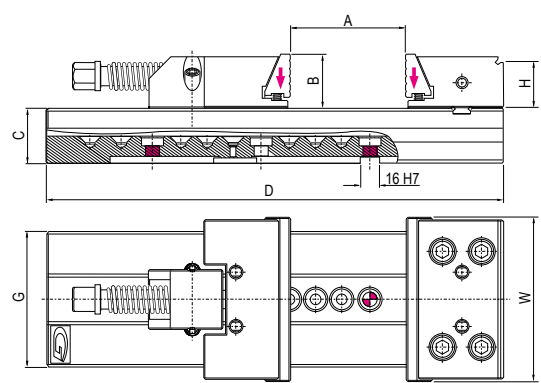
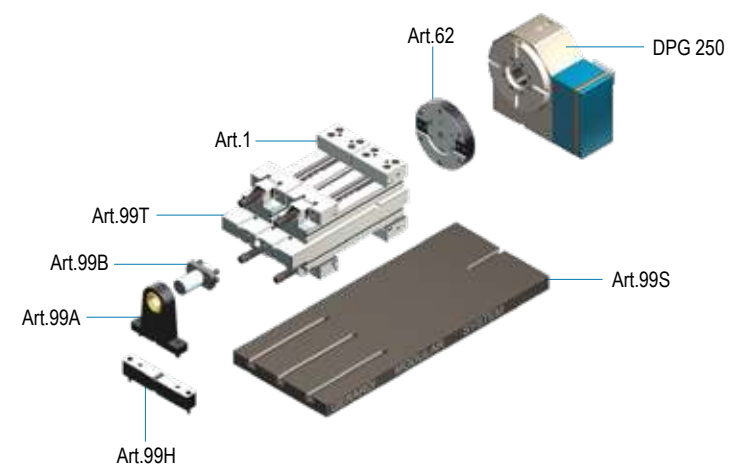

Vedi gruppo 4 per gamma completa accessori
 See group 4 for complete range of accessories

DIVISORE MECCANICO DIVIGER 205

MECHANICAL DIVIDING HEAD DIVIGER 205

NEW!
Divisore automatico
 Automatic dividing head

Dati tecnici
 Technical Data

DIVIGER 205

Diametro del divisore Dividing head diameter	220 mm
Diametro del foro passante Clearance hole diameter	85 mm
Altezza centrale Center height	200 mm
Dimensione della scanalatura a T T-Slot width	-
Sistema di bloccaggio Clamping system	Meccanico Mechanical
Minimo incremento Minimum increment	1°
Precisione Indexing accuracy	±10 Sec.
Coppia in lavoro Driving torque	 3000 Nm
Kg	93
Cod.	7.66.73000

 DIVISORE MECCANICO, SENZA CAVI O IDRAULICA,
 PERMACCHINE A CNC

 MECHANICAL DIVIDING HEAD, WITHOUT ELECTRICAL CABLES
 OR HYDRAULIC, FOR CNC MILLING MACHINE

- Maggiore efficienza nella lavorazione su più lati
- Completamente autonomo dalla macchina
- Elevato momento torcente
- Divisione manuale o automatica tramite mandrino macchina
- 360 posizioni
- Serraggio simultaneo di due particolari grazie alla doppia flangia
- lavorazione su 5 facce senza contropunta
- Lavorazione a barra grazie al mandrino cavo
- Utilizzabile orizzontalmente o verticalmente
- Cambio tramite serraggio a cuneo
- Cost-effective on multiple-sides machining
- Machine independent
- High holding torque
- Dividing manually or automatically using the machine spindle
- 360 x 1° division
- Simultaneous clamping of 2 workpieces thanks to the dual flange
- 5 faces machining without counter-holder
- Bar machining due to hollow spindle
- To be used horizontally or vertically
- Quick change through wedge clamping

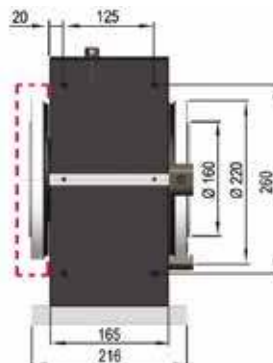
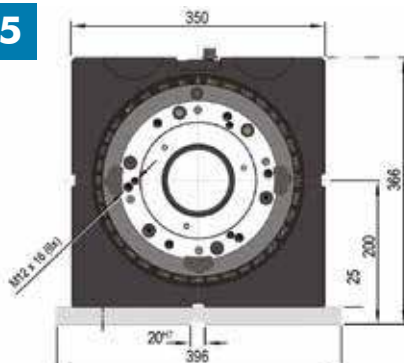

DIVIGER 205

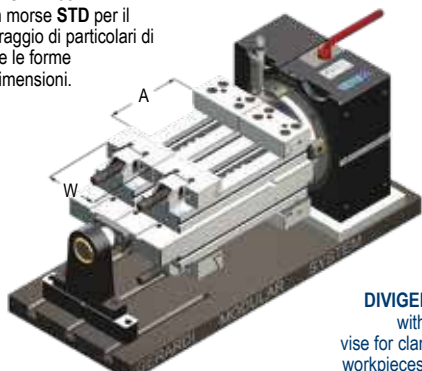
Tipo (grandezza) morsa / Vise type (size)	1		2		3		4			
	Double		Double		Double		Double			
Apertura massima / Maximum spread	A	100	150	200	300	200	300	400	500	
DIVIGER 205 con morse STD per il serraggio di particolari di tutte le forme e dimensioni.	W	96	121	146		171				
	B	28	38	48		58				
	C	35	40	50		58				
	D	270	345	420	520	455	555	655	755	
	G	75	95	125		145				
	Cod.	1.DI.V20500	1.DI.V20510	1.DI.V20520	1.DI.V20530	1.DI.V20540	1.DI.V20550	1.DI.V20560	1.DI.V20570	

DIVIGER 205 with STD
 vise for clamping workpieces of all shapes and sizes.

UPGRADE YOUR VISE APPLICATIONS THROUGH MODULAR ACCESSORIES !

Art. 99A Supporto Support



Cod. 7.99.A1000

Art. 99B Perno di centraggio orizzontale Horizontal centering pin



Cod. 1.99.B1000

Art. 99H Distanziale Spacer



Cod. 1.99.H1000

Art. 62 **DIVIGER 205** Piastra di interfaccia DIVIGER 205 per STD DIVIGER 205 connecting plate for STD



Cod. 1.62.DIV205

Art. 99T Sovratavola per divisore Head-plate for dividing head



Cod. 1.99.T1000 1.99.T2000 1.99.T3200 1.99.T3300 1.99.T4200 1.99.T4300 1.99.T4400 1.99.T4500

Art. 99S Piastra base con cave Piani rettificati Base plate with slot Faces ground

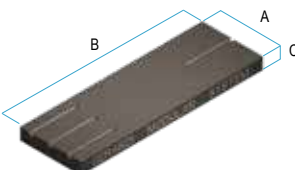

Dimensioni B mm Dimension B mm	A	C	Kg	Cod.	€
600	400	50	94	7.99.S060S	
750	400	50	117	7.99.S075S	
900	400	50	141	7.99.S090S	
1100	400	50	172	7.99.S110S	

 Cave o fori calibrati su richiesta
 Slot or calibrated holes on request

Disponibili quote "B" a step di 50mm - Available dimension "B" in steps of 50mm

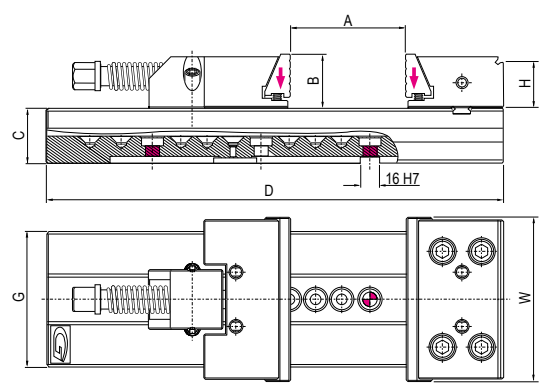
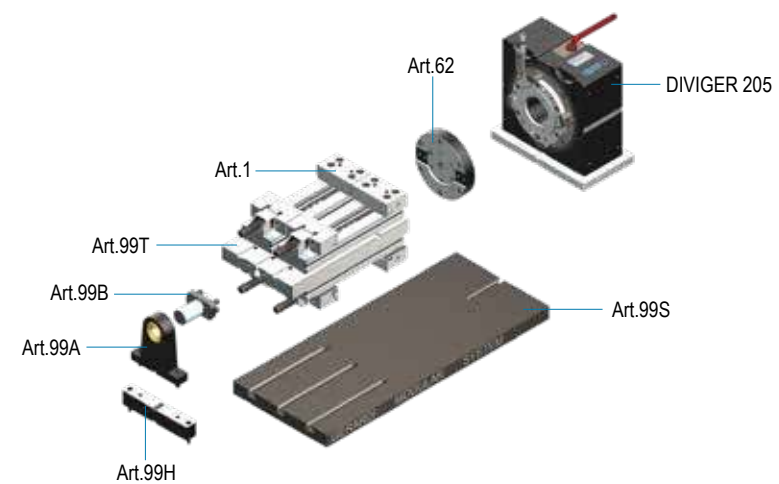
 Vedi gruppo 4 per gamma completa accessori
 See group 4 for complete range of accessories

DIAGRAMMI SERRAGGIO MECCANICO CON CHIAVE DINAMOMETRICA

DIAGRAMS MECHANICAL CLAMPING WITH TORQUE WRENCH

Art. 1 / 1A / 700
GRUPPI DI SERRAGGIO MECCANICI

 (**Art. 258** e similari)

I diagrammi seguenti consentono di determinare le forze di serraggio ottenibili con le morse di varia grandezza (da 1 a 6), in funzione del momento applicato

MECHANICAL CLAMPING DEVICES

 (**Art. 258** and similar)

The following diagrams give the clamping force that can be obtained with each vise type (size 1 to 6) depending on the torque

MORSE STD e StandardFLEX TIPO
STD and StandardFLEX VISES TYPE 1

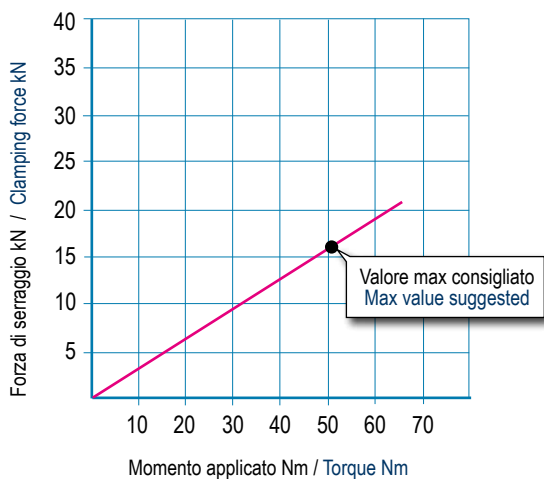
 Vite M12 - Passo 1,75mm
 Screw M12 - Pitch 1,75m

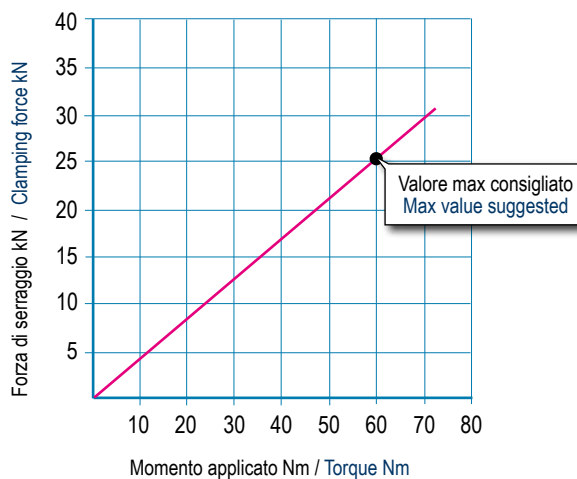
MORSE STD e StandardFLEX TIPO
STD and StandardFLEX VISES TYPE 2

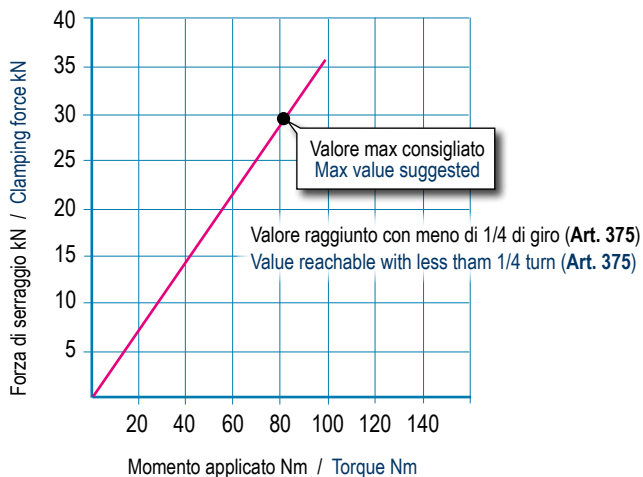
 Vite TPN18 - Passo 4mm
 Screw TPN18 - Pitch 4mm

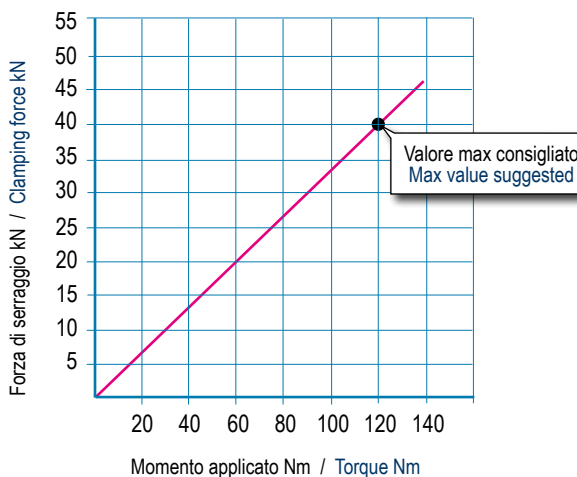
MORSE STD e StandardFLEX TIPO
STD and StandardFLEX VISES TYPE 3-4

 Vite TPN24 - Passo 5mm
 Screw TPN24 - Pitch 5mm

MORSE STD e StandardFLEX TIPO
STD and StandardFLEX VISES TYPE 5-6

 Vite TPN30 - Passo 5mm
 Screw TPN30 - Pitch 5mm

 NB: Alcuni fattori, come la lubrificazione, lo staffaggio, gli attriti ed altro, possono modificare i valori indicati fino a $\pm 10\%$. Per un corretto utilizzo non superare i valori indicati nel grafico

 Some factor as lubrication, clamping on the machine table, frictions and more can modify above values within a $\pm 10\%$ range. For optimum operation do not exceed chart values.

OK Series MORSE - VISES



3 MICRONS ACCURACY

MORSE serie OK, MORSE DI PRECISIONE PER RETTIFICA

OK series VISES, HIGHEST ACCURACY VISES FOR GRINDING OPERATIONS

Una serie di morse per le esigenze più impegnative nei lavori con le tolleranze più ristrette
 A series of vises for the highest accuracy machining operations

L'ALTISSIMA PRECISIONE è OK
 THE HIGHEST ACCURACY VISE IS OK

Principali caratteristiche delle morse serie OK

- Superfici rettificate, temperate e lappate
- Ortogonalità e parallelismo: 0,003 mm / 100 mm
- Ideali per operazioni di controllo, rettifica, elettroerosione e fresatura

Main OK vises technical features

- All case hardened and hardened HRC 60 steel
- Squareness and parallelism: 0,003 mm / 100 mm
- Ideal for grinding E.D.M. machine and for milling operations also for checking and control

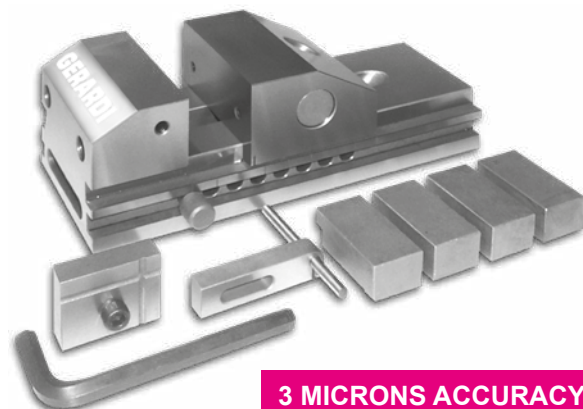

3 MICRONS ACCURACY

Tipo (grandezza) morsa / Vise type (size)	kN	0	1	2	3	4	5	6	7	8
				16 kN	16 kN	18 kN	18 kN	18 kN	18 kN	20 kN
Apertura massima / Maximum spread	A	27	80	100	120	160	180	200	260	200
	W	30	60	75	100	125	125	125	125	160
	B	15	28	40	45	50	50	50	50	63
	C	15	28	35	42	50	50	50	50	63
	D	75	175	220	260	330	350	370	430	410
	E	15	40	50	55	65	65	65	65	80
	F	33	55	50	85	105	105	105	110	130
kg		0,28	2,820	5,820	10,740	19,450	20,080	20,720	26,720	38
Cod.		3.66.60000	3.66.61000	3.66.62000	3.66.63000	3.66.64000	3.66.65000	3.66.66000	3.66.67000	3.66.68000

Art. 666

Morsa serie OK in acciaio / Series OK vises in steel

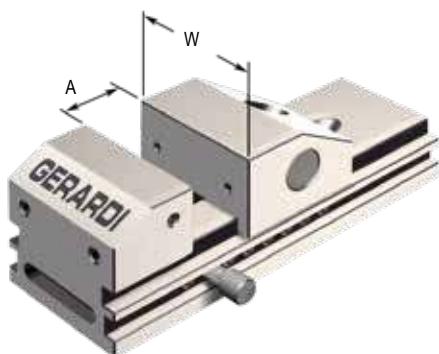

Art. 666S

Morsa serie OK in acciaio Tipo *X4 CR14 per elettroerosione. Stesse caratteristiche dell'Art. 666

Series OK vises in steel Type *X4 CR14 for E.D.M. machines. Same characteristic and dimension of the Art. 666

* Acciaio temprato a basso contenuto di ferro (Max resistenza alla corrosione dopo tempra, rinvenimento e rettifica)
 Low carbon hardened steel (max resistance against corrosion after hardening process and grinding operations)

Cod. 3.66.6S000 3.66.6S100 3.66.6S200 3.66.6S300 3.66.6S400 3.66.6S500 3.66.6S600 3.66.6S700 3.66.6S800

Dotazione standard:

- 4 staffe di fissaggio Art. 666O
- 1 arresto laterale fisso Art. 666G ■ 1 arresto laterale mobile Art. 666I

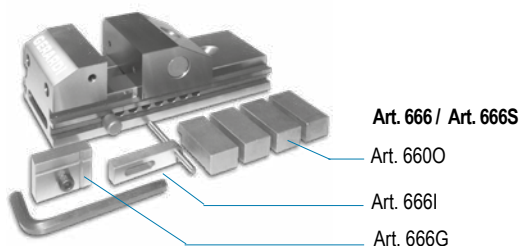

Standard equipment:

- 4 clamping jaws Art. 666O
- 1 fixed work stop Art. 666G ■ 1 movable work stop Art. 666I

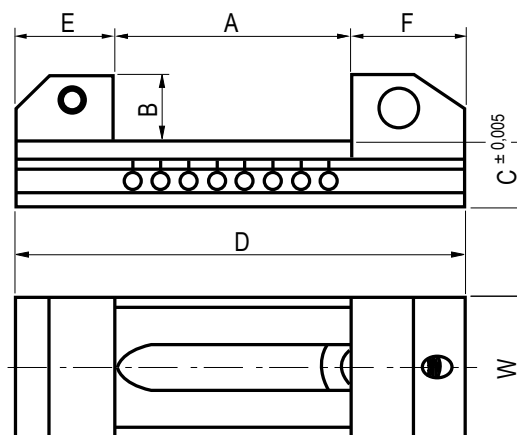

Tipo (grandezza) morsa / Vise type (size)	0	1	2	3	4	5	6	7	8
			16 kN	16 kN	18 kN	18 kN	18 kN	18 kN	20 kN

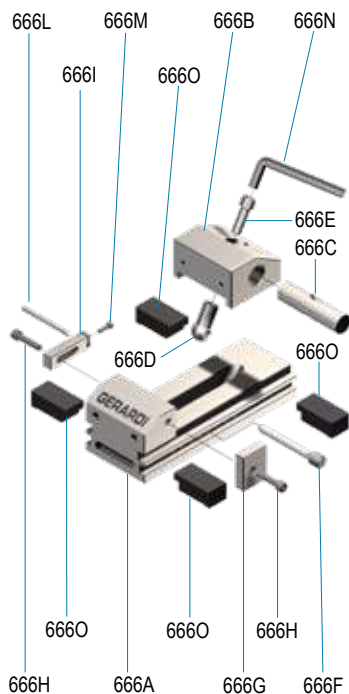
Parti di ricambio per Art. 666 / Spare parts for Art. 666
Art. 666

Art. 666A	Cod.	7.66.6A000	7.66.6A100	7.66.6A200	7.66.6A300	7.66.6A400	7.66.6A500	7.66.6A600	7.66.6A700	7.66.6A800
Art. 666B	Cod.	7.66.6B000	7.66.6B100	7.66.6B200	7.66.6B300	7.66.6B400	7.66.6B500	7.66.6B600	7.66.6B700	7.66.6B800
Art. 666C	Cod.	7.66.6C000	7.66.6C100	7.66.6C200	7.66.6C300	7.66.6C400	7.66.6C500	7.66.6C600	7.66.6C700	7.66.6C800
Art. 666D	Cod.	7.66.6D000	7.66.6D100	7.66.6D200	7.66.6D300	7.66.6D400	7.66.6D500	7.66.6D600	7.66.6D700	7.66.6D800
Art. 666E	Cod.	7.66.6E000	7.66.6E100	7.66.6E200	7.66.6E300	7.66.6E400	7.66.6E500	7.66.6E600	7.66.6E700	7.66.6E800
Art. 666F	Cod.	7.66.6F000	7.66.6F100	7.66.6F200	7.66.6F300	7.66.6F400	7.66.6F500	7.66.6F600	7.66.6F700	7.66.6F800
Art. 666G	Cod.	7.66.6G000	7.66.6G100	7.66.6G200	7.66.6G300	7.66.6G400	7.66.6G500	7.66.6G600	7.66.6G700	7.66.6G800
Art. 666H	Cod.	7.66.6H000	7.66.6H100	7.66.6H200	7.66.6H300	7.66.6H400	7.66.6H500	7.66.6H600	7.66.6H700	7.66.6H800
Art. 666I	Cod.	7.66.6I000	7.66.6I100	7.66.6I200	7.66.6I300	7.66.6I400	7.66.6I500	7.66.6I600	7.66.6I700	7.66.6I800
Art. 666L	Cod.	7.66.6L000	7.66.6L100	7.66.6L200	7.66.6L300	7.66.6L400	7.66.6L500	7.66.6L600	7.66.6L700	7.66.6L800
Art. 666M	Cod.	7.66.6M000	7.66.6M100	7.66.6M200	7.66.6M300	7.66.6M400	7.66.6M500	7.66.6M600	7.66.6M700	7.66.6M800
Art. 666N	Cod.	7.66.6N000	7.66.6N100	7.66.6N200	7.66.6N300	7.66.6N400	7.66.6N500	7.66.6N600	7.66.6N700	7.66.6N800
Art. 666O	Cod.	7.66.6O000	7.66.6O100	7.66.6O200	7.66.6O300	7.66.6O400	7.66.6O500	7.66.6O600	7.66.6O700	7.66.6O800

Tipo (grandezza) morsa / Vise type (size)	0	1	2	3	4	5	6	7	8
			16 kN	16 kN	18 kN	18 kN	18 kN	18 kN	20 kN

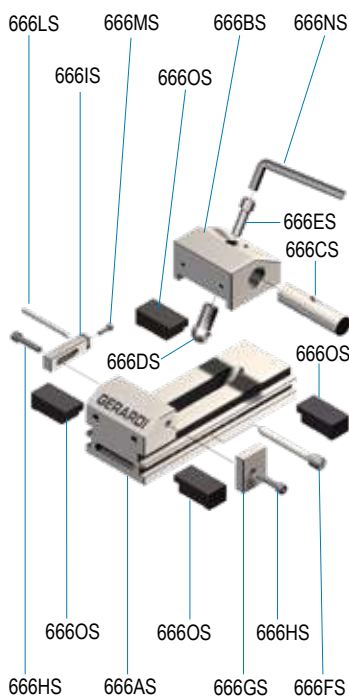
Parti di ricambio in acciaio inox per Art. 666S / Spare parts in stainless steel for Art. 666
Art. 666S

Art. 666AS	Cod.	7.66.6AS00	7.66.6AS10	7.66.6AS20	7.66.6AS30	7.66.6AS40	7.66.6AS50	7.66.6AS60	7.66.6AS70	7.66.6AS80
Art. 666BS	Cod.	7.66.6BS00	7.66.6BS10	7.66.6BS20	7.66.6BS30	7.66.6BS40	7.66.6BS50	7.66.6BS60	7.66.6BS70	7.66.6BS80
Art. 666CS	Cod.	7.66.6CS00	7.66.6CS10	7.66.6CS20	7.66.6CS30	7.66.6CS40	7.66.6CS50	7.66.6CS60	7.66.6CS70	7.66.6CS80
Art. 666DS	Cod.	7.66.6DS00	7.66.6DS10	7.66.6DS20	7.66.6DS30	7.66.6DS40	7.66.6DS50	7.66.6DS60	7.66.6DS70	7.66.6DS80
Art. 666ES	Cod.	7.66.6ES00	7.66.6ES10	7.66.6ES20	7.66.6ES30	7.66.6ES40	7.66.6ES50	7.66.6ES60	7.66.6ES70	7.66.6ES80
Art. 666FS	Cod.	7.66.6FS00	7.66.6FS10	7.66.6FS20	7.66.6FS30	7.66.6FS40	7.66.6FS50	7.66.6FS60	7.66.6FS70	7.66.6FS80
Art. 666GS	Cod.	7.66.6GS00	7.66.6GS10	7.66.6GS20	7.66.6GS30	7.66.6GS40	7.66.6GS50	7.66.6GS60	7.66.6GS70	7.66.6GS80
Art. 666HS	Cod.	7.66.6HS00	7.66.6HS10	7.66.6HS20	7.66.6HS30	7.66.6HS40	7.66.6HS50	7.66.6HS60	7.66.6HS70	7.66.6HS80
Art. 666IS	Cod.	7.66.6IS00	7.66.6IS10	7.66.6IS20	7.66.6IS30	7.66.6IS40	7.66.6IS50	7.66.6IS60	7.66.6IS70	7.66.6IS80
Art. 666LS	Cod.	7.66.6LS00	7.66.6LS10	7.66.6LS20	7.66.6LS30	7.66.6LS40	7.66.6LS50	7.66.6LS60	7.66.6LS70	7.66.6LS80
Art. 666MS	Cod.	7.66.6MS00	7.66.6MS10	7.66.6MS20	7.66.6MS30	7.66.6MS40	7.66.6MS50	7.66.6MS60	7.66.6MS70	7.66.6MS80
Art. 666NS	Cod.	7.66.6NS00	7.66.6NS10	7.66.6NS20	7.66.6NS30	7.66.6NS40	7.66.6NS50	7.66.6NS60	7.66.6NS70	7.66.6NS80
Art. 666OS	Cod.	7.66.6OS00	7.66.6OS10	7.66.6OS20	7.66.6OS30	7.66.6OS40	7.66.6OS50	7.66.6OS60	7.66.6OS70	7.66.6OS80

Tipo (grandezza) morsa / Vise type (size)

Apertura massima / Maximum spread

A

130

130

Forza di serraggio / Clamping force

kN

15

30

Art. 671

Morse pneumatiche / Pneumatic vises

 Ingresso aria 3/4" gas - Ø 8 - 7bar
 Air inlet 3/4" gas - Ø 8 - 7bar

Tipo / Type 1



Tipo / Type 2

Cod.

1.67.11000

1.67.12000

- Costruita in acciaio di alta qualità, cementato e temprato
Durezza HRC58-62
- Ortogonalità e parallelismo: 0,02 mm
- Superfici rettificate, temprate e lappate
- Utilizzabili con pressione aria a 6bar (Connessione 1/4" gas)
- Made in high-quality alloy steel, case harden HRC58-62
- Squareness and parallelism: 0,02 mm
- Ideal for grinding E.D.M. machine and for milling operations also for checking and control
- Rating air pressure is 6bar (Air inlet - 1/4 " gas)

Dotazione standard: 1 arresto laterale Art. 370

Raccordo per aria (1/4" gas - Ø8) Art. PN04

Standard equipment: Workstop Art 370

Air connection (1/4" gas - Ø8) Art. PN04

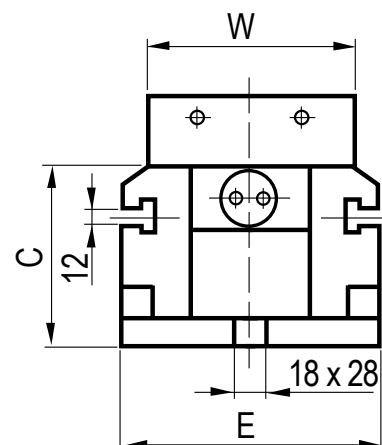
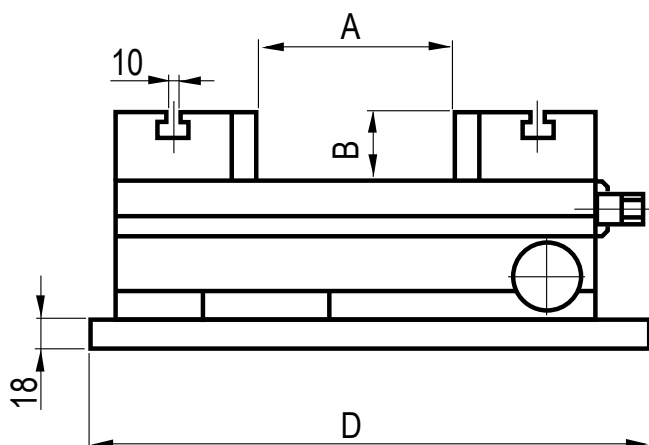

Tipo (grandezza) morsa / Vise type (size)	1	2	3	
Apertura massima / Maximum spread	A	100	120	160
Art. 667 Morse di precisione con barraseno (0 - 90°) Precision sine vises (0 - 90°)	W	75	100	125
	B	32	45	50
	C	95	116	139
	D	214	244	303,5
	E	150	200	240
	kg	9	15	26
	Cod.	1.66.71000	1.66.72000	1.66.73000

- Superfici rettificate, temperate e lappate
- **Ortogonalità e parallelismo: 0,003 mm / 100 mm**
- Ideali per operazioni di controllo, rettifica, elettroerosione e fresatura
- All case hardened and hardened HRC 60 steel
- **Squareness and parallelism: 0,003 mm / 100 mm**
- Ideal for grinding E.D.M. machine and for milling operations also for checking and control

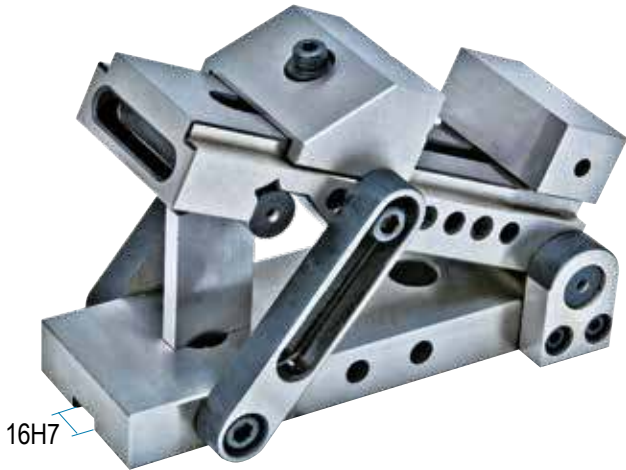

Dotazione standard: 2 chiavi di servizio Art. 376
 Standard equipment: 2 wrenches Art. 376

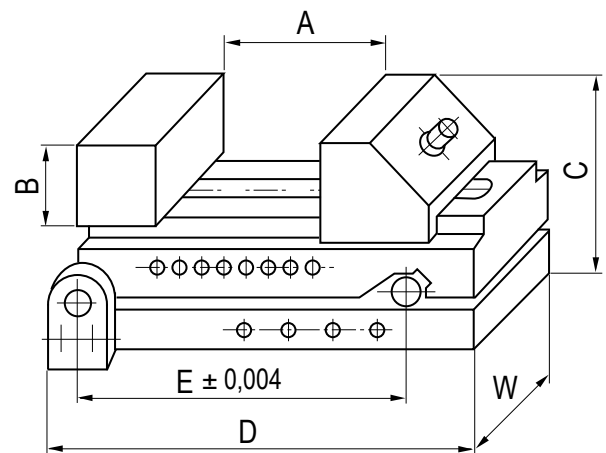

Tipo (grandezza) morsa / Vise type (size)	1	2	3	
Apertura massima / Maximum spread	A	100	150	214
Art. 668 Morse di precisione in acciaio inox Stainless steel precision vises	W	32	32	36
	B	30	35	40
	C	95	100	110
	D	170	226	300
	E	11	11	13,5
	F	9	9	9
	G	34	34	34
	H	50	70	70
	kg	4	5	6
	Cod.	1.66.81000	1.66.82000	1.66.83000

- Costruita in acciaio inox. Durezza HRC50-55
 Parallelismo e ortogonalità 0,005-0,008. Alta resistenza alla corrosione.
 Ideali per operazioni di controllo e elettroerosione
- Made of high quality stainless steel. Hardness HRC50-55.
 Parallelism and squareness of 0,005-0,008 mm. High corrosion-resistance.
 Best for measurement, inspection, EDM and wire-cutting machining.



Dotazione standard: 1 chiave di servizio Art. 376
 Standard equipment: 1 wrench Art. 376

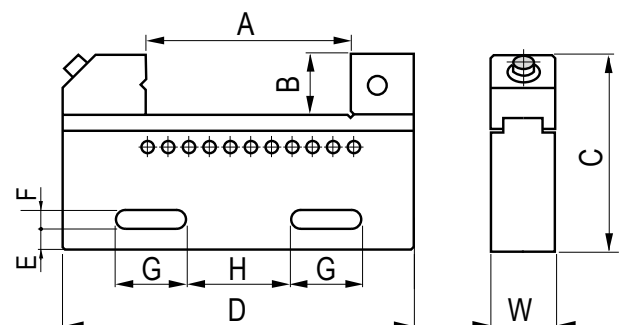

MORSE per RETTIFICA

GRINDING VISES









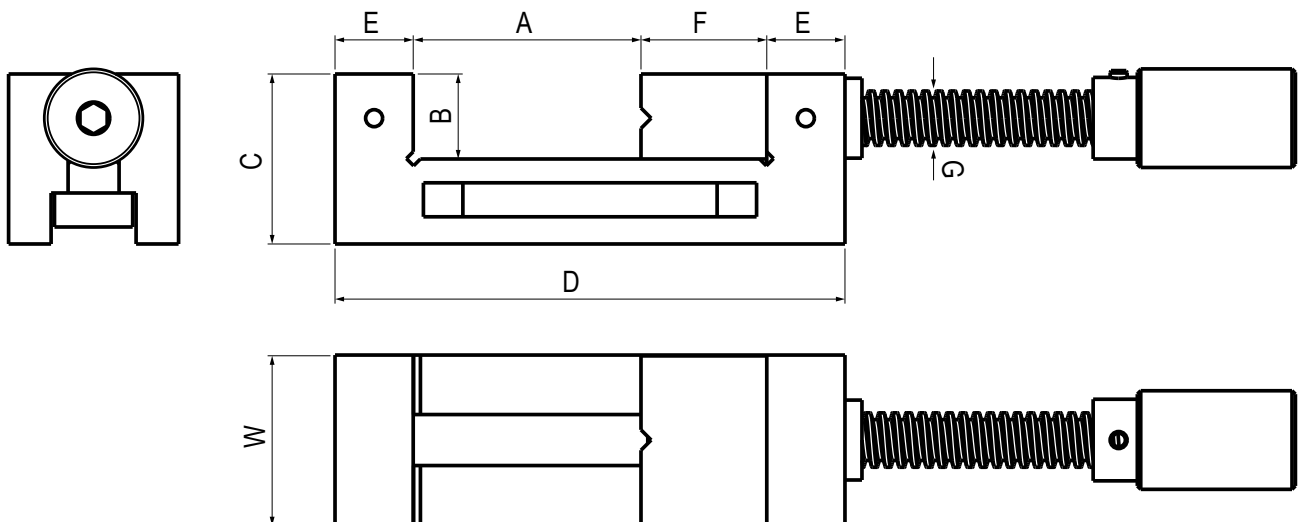
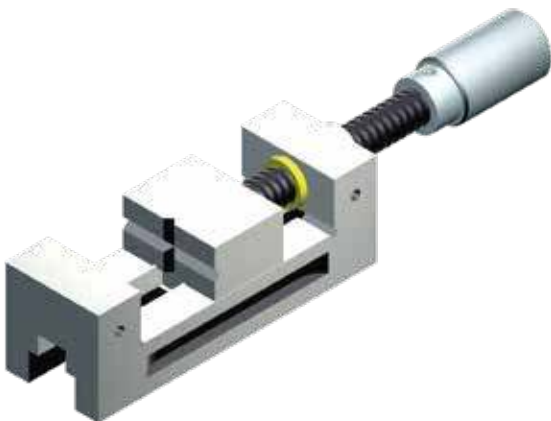

3 MICRONS ACCURACY

Una morsa estremamente precisa, adatta a lavorazioni di rettifica
High precision vise ideal for grinding operations

- Particolarmente adatta per lavori di alta precisione su rettificatrici e apparecchiature di controllo
 - Costruita completamente in acciai temprati a durezza 58/60 HRC
 - Perfettamente rettificata su tutti i suoi piani onde per ottenere i 90° in ogni posizione desiderata
 - La ganaschia mobile ha due V ortogonali per bloccare pezzi cilindrici
 - Tolleranze millesimali: ± 0.003 mm.
- Ideal for high-precision grinding machines or for inspection work
 - Entirely made of non-deformable alloy steel hardened to 58/60 HRC
 - Perfectly ground surfaces in order to reach 90° in any position
 - The movable jaw has two prismatic surfaces in order to clamp round workpieces
 - Accuracy: ± 0.003 mm

Tipo (grandezza) morsa / Vise type (size)	1	2	3	4	5	6	7	
Apertura massima / Maximum spread	A	67	87	102	102	127	160	170
Art. 672	W	50	63	73	80	100	125	150
Morsa serie OK in acciaio / Series OK vises in steel	B	25	31	35	40	45	50	50
	C	50	63	70	80	90	100	100
	D	150	185	205	215	255	315	350
	E	23	28	28	33	38	38	40
	F	37	42	47	47	52	79	100
	G							
	H	215	250	280	390	330	364	399
	kg	2,7	3,7	5,3	6,5	11,1	18,5	21
	Cod.	1.67.21000	1.67.22000	1.67.23000	1.67.24000	1.67.25000	1.67.26000	1.67.27000

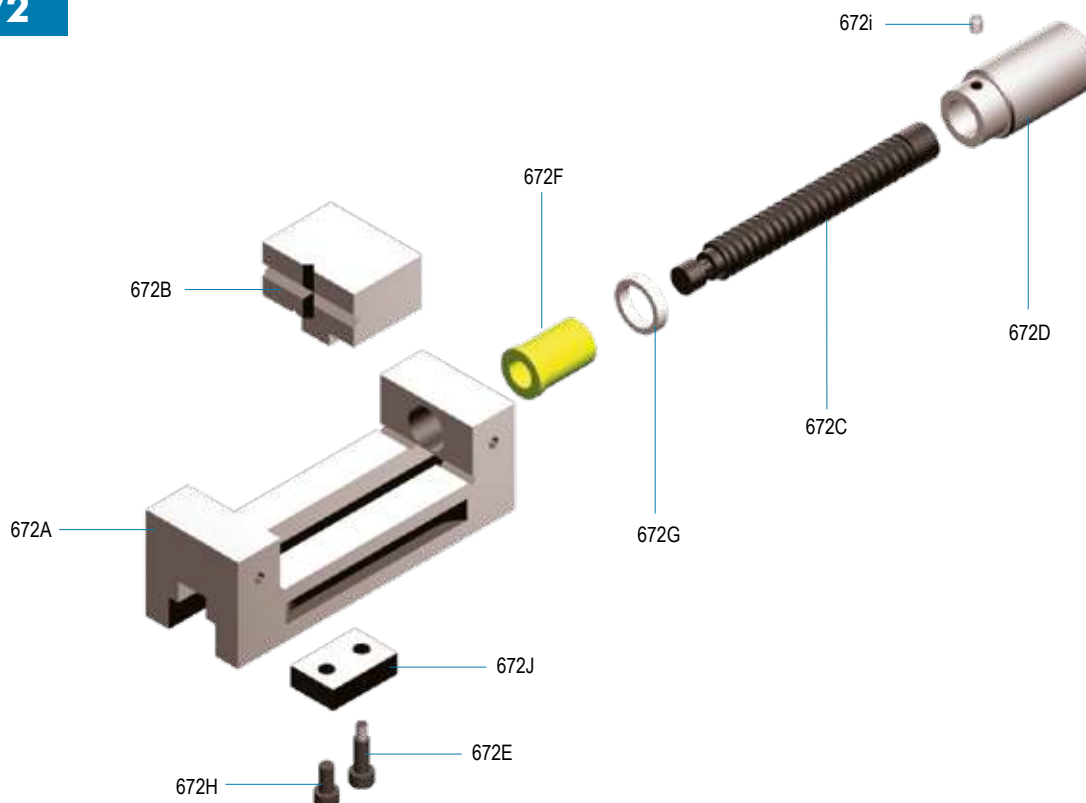

Tipo (grandezza) morsa / Vise type (size)		1	2	3	4	5	6	7
		kN						
Base Morsa Vise Base	 Art. 672A	Cod. 1.67.2A100	1.67.2A200	1.67.2A300	1.67.2A400	1.67.2A500	1.67.2A600	1.67.2A700
Ganascia Mobile Movable Jaw	 Art. 672B	Cod. 1.67.2B100	1.67.2B200	1.67.2B300	1.67.2B400	1.67.2B500	1.67.2B600	1.67.2B700
Vite di Spinta Main Screw	 Art. 672C	Cod. 1.67.2C100	1.67.2C200	1.67.2C300	1.67.2C400	1.67.2C500	1.67.2C600	1.67.2C700
Impugnatura Vite Handle screw	 Art. 672D	Cod. 1.67.2D100	1.67.2D200	1.67.2D300	1.67.2D400	1.67.2D500	1.67.2D600	1.67.2D700
Vite calibrata ganascia mobile Movable jaw shoulder screw	 Art. 672E	Cod. 1.67.2E100	1.67.2E200	1.67.2E300	1.67.2E400	1.67.2E500	1.67.2E600	1.67.2E700
Boccola Bushing	 Art. 672F	Cod. 1.67.2F100	1.67.2F200	1.67.2F300	1.67.2F400	1.67.2F500	1.67.2F600	1.67.2F700
Ghiera Nut	 Art. 672G	Cod. 1.67.2G100	1.67.2G200	1.67.2G300	1.67.2G400	1.67.2G500	1.67.2G600	1.67.2G700
Vite Screw	 Art. 672H	Cod. 1.67.2H100	1.67.2H200	1.67.2H300	1.67.2H400	1.67.2H500	1.67.2H600	1.67.2H700
Vite Screw	 Art. 672I	Cod. 1.67.2I100	1.67.2I200	1.67.2I300	1.67.2I400	1.67.2I500	1.67.2I600	1.67.2I700
Pattino ganascia mobile Sliding plate for movable jaw	 Art. 672J	Cod. 1.67.2J100	1.67.2J200	1.67.2J300	1.67.2J400	1.67.2J500	1.67.2J600	1.67.2J700

Art. 672

DIAGRAMMI SERRAGGIO MECCANICO CON CHIAVE DINAMOMETRICA

DIAGRAMS MECHANICAL CLAMPING WITH TORQUE WRENCH

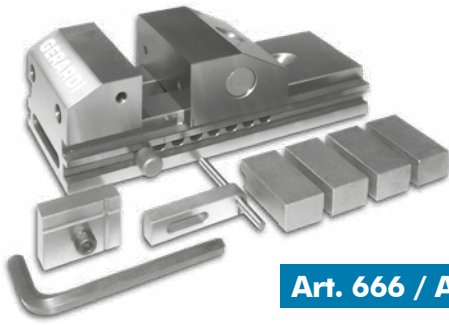
Art. 666 / Art. 666S

I diagrammi seguenti consentono di determinare le forze di serraggio ottenibili con le morse di varia grandezza (da 2 a 8), in funzione del momento applicato

The following diagrams give the clamping force that can be obtained with each vise type (size 2 to 8) depending on the torque

MORSE OK TIPO **2**

OK VISES TYPE

Chiave dinamometrica BETA 610/10X
 Torque wrench BETA 610/10X

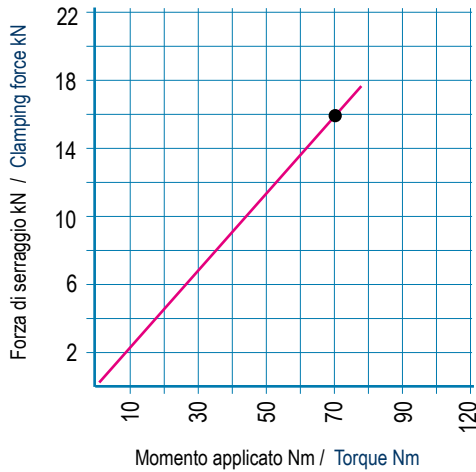

MORSE OK TIPO **3**

OK VISES TYPE

Chiave dinamometrica BETA 610/10X
 Torque wrench BETA 610/10X

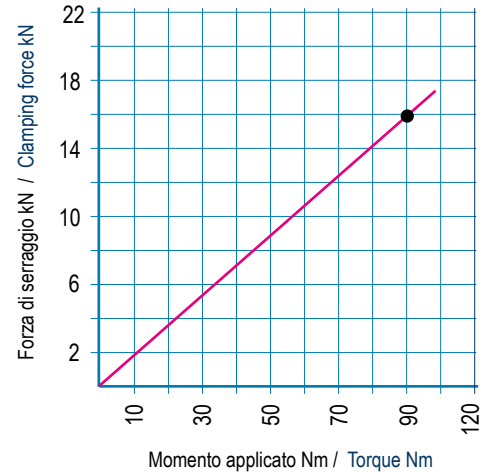

MORSE OK TIPO **4-5-6-7**

OK VISES TYPE

Chiave dinamometrica BETA 610/10X
 Torque wrench BETA 610/10X

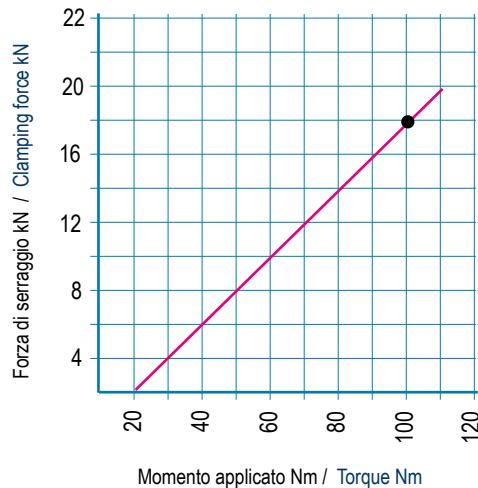

MORSE OK TIPO **8**

OK VISES TYPE

Chiave dinamometrica BETA 610/10X
 Torque wrench BETA 610/10X

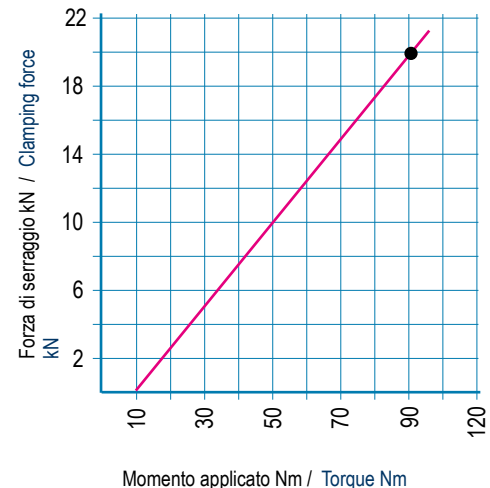

NB: Alcuni fattori, come la lubrificazione, lo staffaggio, gli attriti ed altro, possono modificare i valori indicati fino a $\pm 10\%$. Per un corretto utilizzo non superare i valori indicati nel grafico

Some factor as lubrication, clamping on the machine table, frictions and more can modify above values within a $\pm 10\%$ range. For optimum operation do not exceed chart values.