

SC Standard Scroll Chuck (Hard Jaws)

Thru Hole Range : $\varnothing 16 \sim \varnothing 57$
Clamping Range : $\varnothing 2 \sim \varnothing 180$

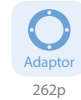

Application / Benefits

For work requiring through hole

Technical features

Reversible one-piece hard jaws

Rear mounting only

Self-centering jaws manually opened by t-handle

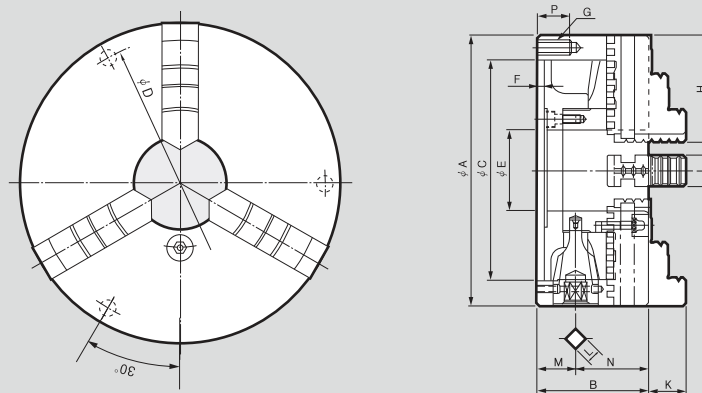

DIMENSIONS

	SC-85(3")	SC-110(4")	SC-130(5")	SC-165(6")	SC-190(7")
ΦA	85	110	130	167	192
B	44.1	58	60	65	75
ΦC(H6)	60	80	100	130	155
ΦD	73	95	115	147	172
ΦE	16	24	34	45	57
F	3.5	4.5	4.5	5	5
G	3-M6	3-M8	3-M8	3-M10	3-M10
H	35	44	50	65	75
J	11	14	16	19	22
K	14.6	20.0	20.1	25.07	30.06
L	7	8	8	10	11
M	17	24.5	22.5	24	27.5
N	27.1	32.35	37	41	47.5
P	13	16	16	20	20

SPECIFICATIONS

	SC-85 (3")	SC-110 (4")	SC-130 (5")	SC-165 (6")	SC-190 (7")
Max. Static Gripping Force [kN(kgf)]	9(918)	12(1224)	15(1530)	31(3161)	31(3161)
Clamping Range External [φmm]	2~70	3~94	3~110	3~160	4~180
Clamping Range Internal [φmm]	24~64	29~84	33~100	48~150	56~170
Handle Torque [N · m(kgf · m)]	29.4(3.0)	44.1(4.1)	63.7(6.5)	88.3(9.0)	107.9(11.0)
Max. r.p.m. [min ⁻¹]	2500	2500	2500	4000	3500
Weight [kg]	1.5	3.1	4.4	11.4	12.2
Moment of inertia [N · m ² (kg · m ²)]	0.05(0.005)	0.17(0.017)	0.35(0.036)	1.18(0.12)	2.35(0.24)

SC Standard Scroll Chuck (Hard Jaws)

Thru Hole Range : $\varnothing 75 \sim \varnothing 130$
Clamping Range : $\varnothing 5 \sim \varnothing 346$

 Adaptor
262p

 H/S Jaw
261p



Application / Benefits

For work requiring through hole

Technical features

Reversible one-piece hard jaws

Rear mounting only

Self-centering jaws manually opened by t-handle

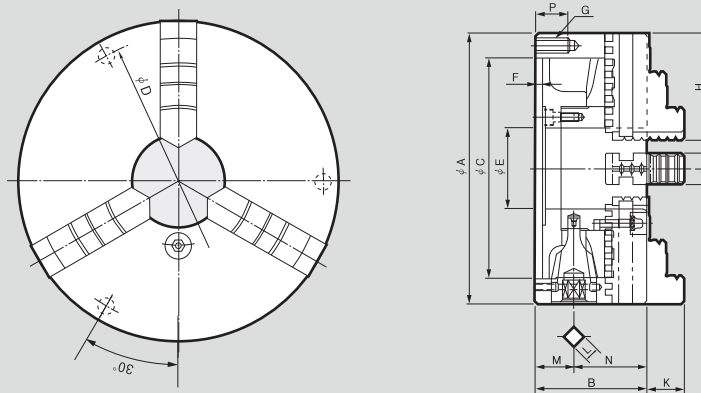

DIMENSIONS

	SC-230(9")	SC-273(10")	SC-310(12")	SC-355(14")	SC-405(16")
ΦA	232	273	310	355	405
B	84	86	96	110	114.5
ΦC(H6)	190	230	260	300	345
ΦD	210	250	285	328	375
ΦE	75	89	100	105	130
F	6	6	7	8	8
G	3-M12	3-M12	3-M12	6-M12	6-M12
H	85	98	110	133	133
J	24	28	30	35	35
K	35.04	40.02	45.08	62.98	63
L	12	12	14	14	15
M	29.5	31.5	31.5	42.4	43
N	54.5	54.5	64.5	67.6	71.5
P	25	25	25	36	36

SPECIFICATIONS

	SC-230 (9")	SC-273 (10")	SC-310 (12")	SC-355 (14")	SC-405 (16")
Max. Static Gripping Force [kN(kgf)]	37(3773)	46(4691)	55(5608)	40.5(4130)	45(4589)
Clamping Range External [φmm]	5~200	5~260	10~300	25~315	25~346
Clamping Range Internal [φmm]	62~210	70~250	86~290	107~290	113~324
Handle Torque [N · m(kgf · m)]	147(15.0)	176.5(18.0)	206(21.0)	225.6(23.0)	245(25.0)
Max. r.p.m. [min ⁻¹]	2900	2500	2200	1500	1500
Weight [kg]	21.2	28	41	54	74
Moment of inertia [N · m ² (kg · m ²)]	6.27(0.64)	9.90(1.01)	23.0(2.35)	37.2(3.8)	67.6(6.9)

* Maximum turning speed is based upon actual measurement.