

NEW  
신제품  
출시

# LIVE CENTER

LIVE CENTER / LATHE CENTER / SPECIAL LIVE CENTER

[www.iwidin.com](http://www.iwidin.com)



 **WIDIN**  
(주)위딘

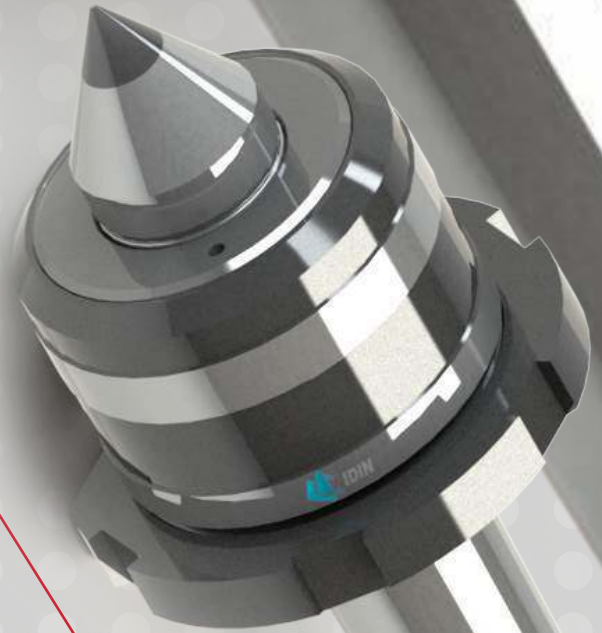

## Greeting

# Making customer's dreams a reality- The best mechanical solution

(주)위딘은 1988년 7월 창업 이래 국내 초경 절삭 공구시장의 질적 향상을 위해 꾸준히 노력해 오고 있습니다.

이와 같은 노력에 힘입어 국내 ENDMILLS, DRILLS, REAMERS, TAPS 뿐만아니라 SPECIAL TOOLS은 반도체 부품, 자동차 부품, 금형 및 공작기계 부품 등과 같은 국내 산업전반에 많은 기여를 하고 있습니다.

인화단결, 창의정신, 주인의식이라는 사훈아래 모든 임직원이 하나로 뜻을 모아 (주)위딘의 발전을 위해 땀을 흘리고, 생산되어지는 제품에 자부심을 가짐으로써 품질의 향상과 불량률 0%를 만들어 나가고 있음은 물론, 끊임없는 품질개선, 생산성 극대화, 기업의 세계화라는 경영방침아래 (주)위딘을 더욱 발전시키기 위해 최선의 노력을 아끼지 않고 있습니다.

이울러 (주)위딘 부설 연구소에서는 품질개선을 위한 끊임없는 연구를 하고 있으며, 그 결과들은 속속 품질의 향상과 신제품 개발로 나타나고 있습니다.

또한, 세계적 박람회인 EMO, JIMTOF, IMTS, SIMTOS 등의 참여 뿐만 아니라 지속적인 해외시장 개척활동으로 품질향상과 회사의 이미지 제고는 물론, 세계를 무대로 국경없는 글로벌 경영을 실현하고 있습니다.

철저한 품질관리와 정확한 납기준수는 물론 고객과 이익을 함께 나누는 자세로 업무에 임할 것을 다짐하고 당사의 축적된 경험과 노하우가 귀사의 생산성 향상과 원가절감에 기여할 수 있도록 최선을 다하겠습니다. 고객 여러분의 꾸준한 관심과 성원에 감사드리며, 끊임없는 노력과 열정으로 임할 것을 약속드립니다.

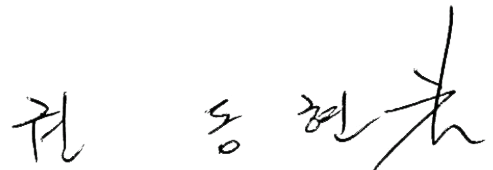

President and CEO Dong Hyun Kwon

# History

## 1988

- 1988. 07 회사설립(주식회사 하나정공)
- 2001. 04 상호변경 (주)하나정공 → (주)하나툴스
- 07 ISO 9001 인증 획득
- 2002. 03 (주)하나툴스 부설연구소 설립인가(과기부)
- 05 실용신안 등록(제0277126호)
- 2003. 06 수출유망중소기업 지정(경남 중소기업 수출지원 센터)
- 2004. 05 실용신안 등록(제0350651)
- 11 제34회 정밀기술진흥대회 동상 수상
- 11 대표이사 산업자원부장관 표창

## 2005

- 2005. 02 상해사무소 개설(중국상하이)
- 04 벤처기업 선정(중소기업청)
- 05 수출전환대상업체 지정(제2005-16호)
- 07 경남중소기업대상 특별상 수상
- 07 수출유망 중소기업 지정(제2005-28호)
- 10 부품소재전문기업(산업자원부)
- 11 기술혁신형중소기업(INNO-BIZ) 확인(중소기업청)
- 2006. 09 창원시 최고경영인상 수상(창원시)
- 11 품질경쟁력 우수기업 선정
- 11 수출 100만불 탑 수상
- 2007. 02 부등분할 엔드밀 특허 획득
- 05 대통령 표창 수상
- 07 상호변경 (주)하나툴스 → (주)위딘
- 2008. 07 창립 20주년 기념 및 회사 이전 준공
- 11 수출 300만불 탑 수상
- 2010. 05 2010 글로벌스탠더드 경영대상 수상(한국능률협회)
- 2011. 11 수출 500만불 탑 수상
- 2012. 01 글로벌 강소 기업 선정
- 06 본사 확장 이전
- 2015. 06 대표이사 국무총리상 수상
- 2016. 05 고성장 수출기업 역량강화사업 선정 기업

## 2016~



# Global Network



## 전세계 41개국 자체 영업망, 그러나 위딘은 멈추지 않습니다.

90년대 후반부터 시작된 수출을 계기로 품질에서 인정받은  
위딘은 세계로 수출하는 글로벌 기업입니다.  
전세계에서 위딘의 제품을 만날 수 있도록  
끊임없이 도약하겠습니다.



그리스  
 남아프리카공화국  
 네덜란드  
 노르웨이  
 뉴질랜드  
 독일  
 덴마크  
 러시아  
 말레이시아  
 멕시코  
 미국

베트남  
 벨기에  
 브라질  
 스페인  
 스웨덴  
 스위스  
 슬로베니아  
 싱가포르  
 아르헨티나  
 영국  
 오스트리아

이란  
 이집트  
 이탈리아  
 인도  
 인도네시아  
 일본  
 중국  
 체코  
 콜롬비아  
 캐나다  
 태국

터키  
 포르투갈  
 폴란드  
 프랑스  
 필리핀  
 호주  
 홍콩  
 헝가리



# 라이브센터 분류

## SHAFT 회전

**LC-NC**

- NC선반 가공전용 For NC Lathe machining
- 이물질 유입 방지 Prevention of the inflow of foreign substance



**LC-NCP**

- NC TYPE 개선형 모델 Advanced NC TYPE Model



**LC-NK**

- 중절삭, 고하중 가공용 Use for heavy cutting, heavy duty



**LC-SM**

- NC선반 고속 회전용 Use for high speed rotation NC lathe



**LC-SMP**

- SM TYPE 개선형 모델 Advanced SM TYPE Model



**LC-GR**

- 연마기 전용, 중, 고하중 전용 For Grinding machine, heavy cutting and heavy duty



**LC-D50**

- NC선반 가공전용 For NC lathe machining
- 공구간섭 최소화 모델 Minimize the bite-interference



**LC-HD**

- 범용 선반 전용 For Wide-use Lathe



**LC-HDS**

- HD TYPE 개선형 모델 Advanced HD TYPE Model



**LC-HDS**

- PIPE 가공 전용 모델 Exclusive model of PIPE Machining



## CAP 회전

# CONTENTS

## LC-NC TYPE 01

- 11 NC TYPE
- 11 NCB TYPE
- 11 NCC TYPE
- 12 NCBC TYPE
- 12 NCN TYPE
- 12 NCBN TYPE
- 13 NCCN TYPE
- 13 NCBCN TYPE



## LC-NCP TYPE 02

- 15 NCP TYPE
- 15 NCPB TYPE
- 15 NCPC TYPE
- 16 NCPBC TYPE
- 16 NCPN TYPE
- 16 NCPBN TYPE
- 17 NCPCN TYPE
- 17 NCPBCN TYPE



## LC-SMP TYPE 05

- 29 SMP TYPE
- 29 SMPB TYPE
- 29 SMPN TYPE
- 30 SMPBC TYPE
- 30 SMPBN TYPE
- 31 SMPN TYPE
- 31 SMPBN TYPE



## LC-D50 TYPE 06

- 33 D50 TYPE
- 33 D50B TYPE
- 33 D50C TYPE
- 34 D50BC TYPE



## LM CENTER 09

- 41 LM-A TYPE
- 41 LM-AC TYPE
- 42 LM-AN TYPE
- 42 LM-CN TYPE



## LM-H CENTER 10

- 44 LM-H TYPE
- 44 LM-HC TYPE
- 45 LM-HN TYPE
- 45 LM-HCN TYPE





### LC-NK · NKD TYPE — 03

- 19 NK TYPE
- 19 NKB TYPE
- 19 NKC TYPE
- 20 NKBC TYPE
- 20 NKN TYPE
- 20 NKBN TYPE
- 21 NKCN TYPE
- 21 NKBCN TYPE
- 22 NKD TYPE



### LC-GR · SM TYPE — 04

- 24 GR TYPE
- 24 SM TYPE
- 25 SMB TYPE
- 25 SMC TYPE
- 26 SMBC TYPE
- 26 SMN TYPE
- 26 SMBN TYPE
- 27 SMCN TYPE
- 27 SMBCN TYPE

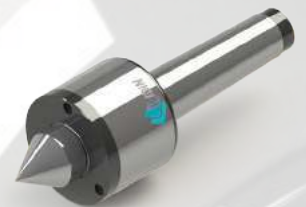

### LC-HD TYPE — 07

- 36 HD TYPE
- 36 HDC TYPE
- 36 HDS TYPE
- 37 HDSC TYPE
- 37 HDSTH TYPE



### LC-PT TYPE — 08

- 39 PT-60 TYPE
- 39 PT-80 TYPE



# 01

NC-TYPE

## LC-NC

- NC선반에 적합한 라이브센터
- 절삭유 및 이물질 유입 방지
- 3중 베어링 구조로 정밀도가 높고 수명이 길다
- SHAFT 열처리 경도 HRC58~62
- RUN OUT 0.003

- Live Center for CNC lathe
- Prevent the inflow of cutting oil and foreign substance
- High degree of accuracy of rotation and high durability by using the triplexed bearing structure as high degree of precision
- Heat treatment hardness of Shaft : HRc58-62
- RUN OUT 0.003



### NCB TYPE

바이트 간섭 최소화  
Minimize the bite-interference



### NCBC TYPE

바이트 간섭 최소화 / 초경타입  
Minimize the bite-interference / Carbide Type



### NCBN TYPE

바이트 간섭 최소화 / 너트타입  
Minimize the bite-interference / Nut Type



### NCBCN TYPE

바이트 간섭 최소화 / 초경, 너트 타입  
Minimize the bite-interference / Carbide, Nut Type



### NCC TYPE

초경타입  
Carbide Type



### NCN TYPE

너트타입  
Nut Type



### NCCN TYPE

초경, 너트타입  
Carbide, Nut Type



# NC-TYPE

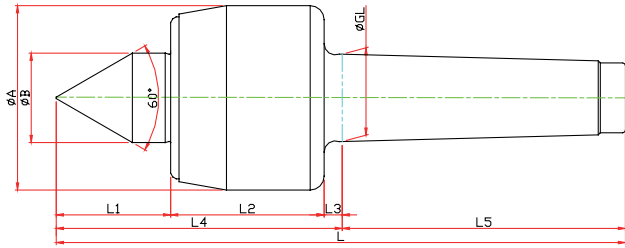

Model	Order Number	Morse Taper	Dimension										Weight MAX.	R.P.M MAX.	Run Out
			GL	A	B	L1	L2	L3	L4	L5	L				
LC-3NC	010003	NO.3	23.825	50	22	27	45	5	77	81	158	630	4800	0.003	
LC-4NC	010004	NO.4	31.267	66	32	41	55	6.5	102.5	101.5	204	1100	3800	0.003	
LC-5NC	010005	NO.5	44.399	82	40	50	65	6.5	121.5	129.5	251	1600	3400	0.005	
LC-6NC	010006	NO.6	63.384	105	45	54	80	8	142	182	324	2100	3000	0.005	

# NCB-TYPE

※ SHAFT 확장(바이트 간섭 최소화) SHAFT EXTENSION(Minimize the bite-interference)

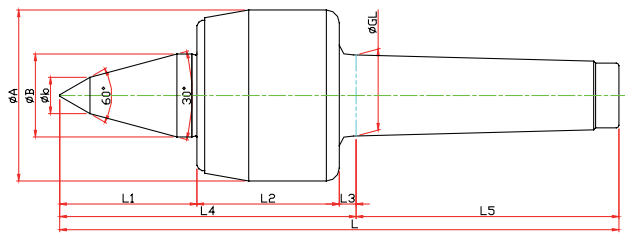

Model	Order Number	Morse Taper	Dimension										Weight MAX.	R.P.M MAX.	Run Out
			GL	A	B	b	L1	L2	L3	L4	L5	L			
LC-3NCB	011003	NO.3	23.825	50	22	10	47	45	5	97	81	178	280	4800	0.003
LC-4NCB	011004	NO.4	31.267	66	32	14	53	55	6.5	114.5	101.5	216	510	3800	0.003
LC-5NCB	011005	NO.5	44.399	82	40	16	65	65	6.5	129.5	129.5	266	750	3400	0.005
LC-6NCB	011006	NO.6	63.384	105	45	18	78	80	8	182	182	348	940	3000	0.005

# NCC-TYPE

※ 초경타입 Carbide Type

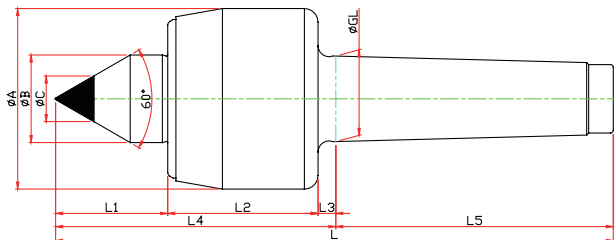

Model	Order Number	Morse Taper	Dimension										Weight MAX.	R.P.M MAX.	Run Out
			GL	A	B	L1	L2	L3	L4	L5	C	L			
LC-3NCC	010103	NO.3	23.825	50	22	27	45	5	77	81	10	158	630	4800	0.003
LC-4NCC	010104	NO.4	31.267	66	32	41	55	6.5	102.5	101.5	14	204	1100	3800	0.003
LC-5NCC	010105	NO.5	44.399	82	40	50	65	6.5	121.5	129.5	18	251	1600	3400	0.005
LC-6NCC	010106	NO.6	63.384	105	45	54	80	8	142	182	25	324	2100	3000	0.005

# NCBC-TYPE

- ※ SHAFT 확장(바이트 간섭 최소화) SHAFT EXTENTION(Minimize the bite-interference)
- ※ 초경타입 Carbide Type

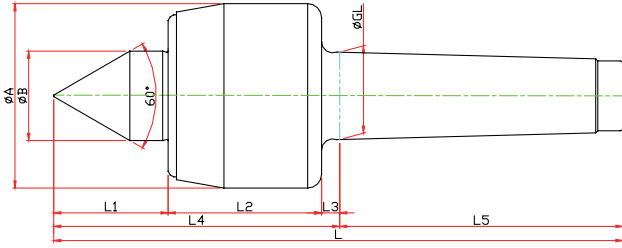

Model	Order Number	Morse Taper	Dimension										Weight MAX.	R.P.M MAX.	Run Out
			GL	A	B	L1	L2	L3	L4	L5	C	L			
LC-3NCBC	011102	NO.3	23,825	50	22	47	45	5	97	81	10	178	280	4800	0,003
LC-4NCBC	011103	NO.4	31,267	66	32	53	55	6.5	114.5	101.5	14	216	510	3800	0,003
LC-5NCBC	011104	NO.5	44,399	82	40	65	65	6.5	136.5	129.5	16	266	750	3400	0,005
LC-6NCBC	011105	NO.6	63,384	105	45	78	80	8	166	182	18	348	940	3000	0,005

# NCN-TYPE

- ※ 너트타입 Nut Type

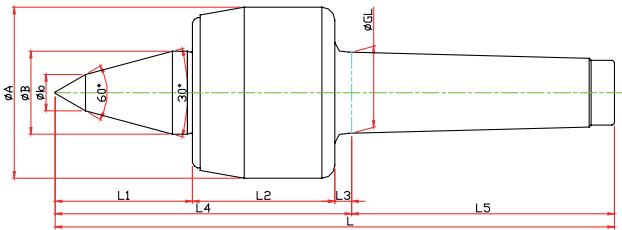

Model	Order Number	Morse Taper	Dimension										Weight MAX.	R.P.M MAX.	Run Out
			GL	A	B	L1	L2	L3	L4	L5	N	L			
LC-3NCN	010013	NO.3	23,825	50	22	27	45	5	77	81	70	158	630	4800	0,003
LC-4NCN	010014	NO.4	31,267	66	32	41	55	6.5	102.5	101.5	85	204	1100	3800	0,003
LC-5NCN	010015	NO.5	44,399	82	40	50	65	6.5	121.5	129.5	105	251	1600	3400	0,005
LC-6NCN	010016	NO.6	63,384	105	45	54	80	8	142	182	130	324	2100	3000	0,005

# NCBN-TYPE

- ※ SHAFT 확장(바이트 간섭 최소화) SHAFT EXTENTION(Minimize the bite-interference)
- ※ 너트타입 Nut Type

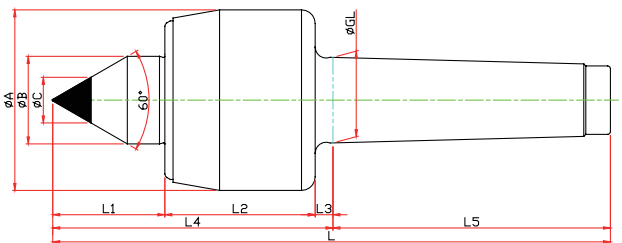

Model	Order Number	Morse Taper	Dimension											Weight MAX.	R.P.M MAX.	Run Out
			GL	A	B	b	L1	L2	L3	L4	L5	N	L			
LC-3NCBN	011013	NO.3	23,825	50	22	10	47	45	5	97	81	70	178	280	4800	0,003
LC-4NCBN	011014	NO.4	31,267	66	32	14	53	55	6.5	114.5	101.5	85	216	510	3800	0,003
LC-5NCBN	011015	NO.5	44,399	82	40	16	65	65	6.5	136.5	129.5	105	266	750	3400	0,005
LC-6NCBN	011016	NO.6	63,384	105	45	18	78	80	8	166	182	130	348	940	3000	0,005

# NCCN-TYPE

※ 너트, 초경타입 Nut, Carbide Type Type

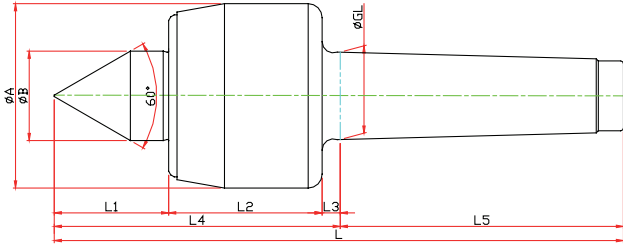

Model	Order Number	Morse Taper	Dimension											Weight MAX.	R.P.M MAX.	Run Out
			GL	A	B	L1	L2	L3	L4	L5	C	N	L			
LC-3NCCN	010113	NO.3	23,825	50	22	27	45	5	77	81	10	70	158	630	4800	0,003
LC-4NCCN	010114	NO.4	31,267	66	32	41	55	6.5	102.5	101.5	14	85	204	1100	3800	0,003
LC-5NCCN	010115	NO.5	44,399	82	40	50	65	6.5	121.5	129.5	18	105	251	1600	3400	0,005
LC-6NCCN	010116	NO.6	63,384	105	45	54	80	8	142	182	25	130	324	2100	3000	0,005

# NCBCN-TYPE

※ SHAFT 확장(바이트 간섭 최소화) SHAFT EXTENTION(Minimize the bite-interference)

※ 너트, 초경타입 Nut, Carbide Type Type

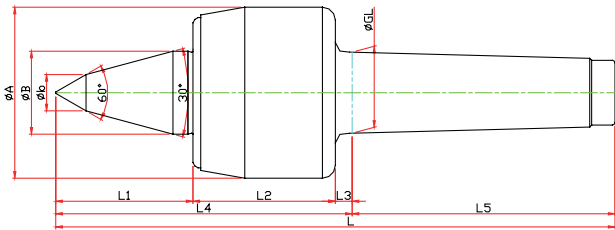

Model	Order Number	Morse Taper	Dimension											Weight MAX.	R.P.M MAX.	Run Out
			GL	A	B	L1	L2	L3	L4	L5	C	N	L			
LC-3NCBCN	011113	NO.3	23,825	50	22	47	45	5	97	81	10	70	178	280	4800	0,003
LC-4NCBCN	011114	NO.4	31,267	66	32	53	55	6.5	114.5	101.5	14	85	216	510	3800	0,003
LC-5NCBCN	011115	NO.5	44,399	82	40	65	65	6.5	136.5	129.5	16	105	266	750	3400	0,005
LC-6NCBCN	011116	NO.6	63,384	105	45	78	80	8	166	182	18	130	348	940	3000	0,005

# NC-SPECIAL

※ 사용자의 조건에 따라 주문, 제작 Customized-special production for user's condition



NC-TYPE

NCP-TYPE

NK·NKD TYPE

GR·SM TYPE

SMP-TYPE

D50 TYPE

HD-TYPE

PT-TYPE

LM CENTER

LM-H CENTER

## LC-NCP

- NC선반에 적합한 라이브센터
  - 절삭유 및 이물질 유입 방지
  - NC TYPE보다 강력한 지지력 및 내구성
  - 3중 베어링 구조로 정밀도가 높고 수명이 길다
  - SHAFT 열처리 경도 HRC58~62
  - RUN OUT 0.003
- Live Center for CNC lathe
  - Prevent the inflow of cutting oil and foreign substance
  - Stronger bearing capacity and durability than NC TYPE
  - High degree of accuracy of rotation and high durability by using the triplexed bearing structure as high degree of precision
  - Heat treatment hardness of Shaft : HRC58~62
  - RUN OUT 0.003



### NCPB TYPE

바이트 간섭 최소화  
Minimize the bite-interference



### NCPBC TYPE

바이트 간섭 최소화 / 초경타입  
Minimize the bite-interference / Carbide Type



### NCPBN TYPE

바이트 간섭 최소화 / 너트타입  
Minimize the bite-interference / Nut Type

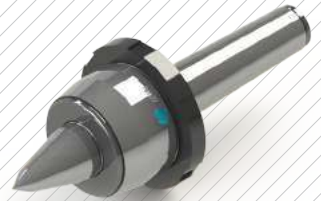

### NCPBCN TYPE

바이트 간섭 최소화 / 초경, 너트 타입  
Minimize the bite-interference / Carbide, Nut Type



### NNPC TYPE

초경타입  
Carbide Type



### NCPN TYPE

너트타입  
Nut Type



### NNPCN TYPE

초경, 너트타입  
Carbide, Nut Type

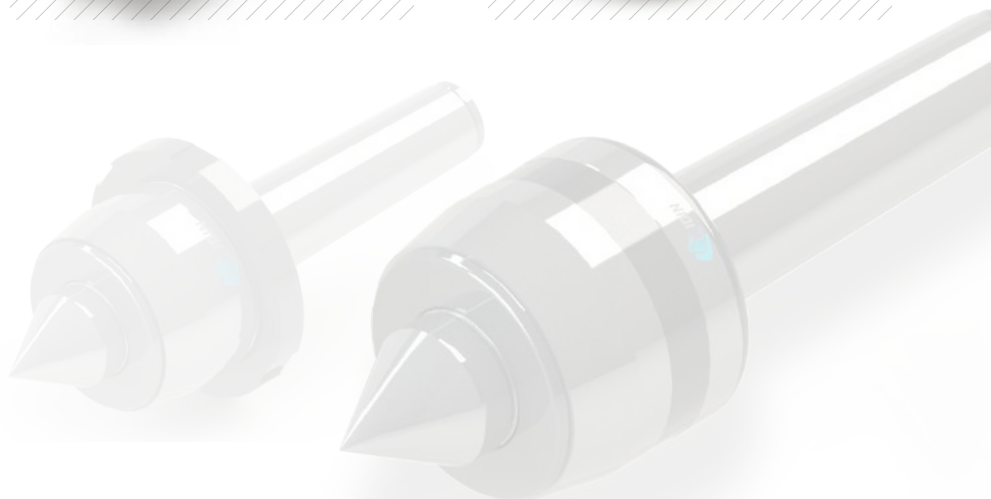
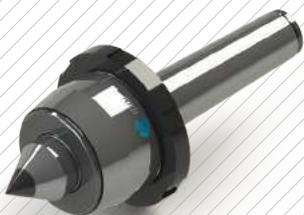

# NCP-TYPE

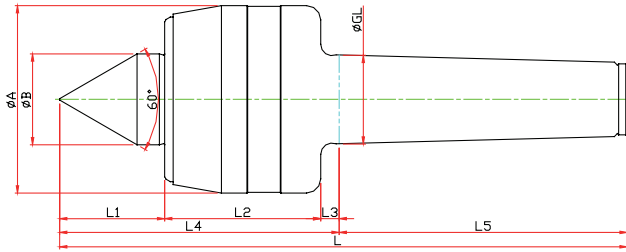

Model	Order Number	Morse Taper	Dimension									Weight MAX.	R.P.M MAX.	Run Out
			GL	A	B	L1	L2	L3	L4	L5	L			
LC-3NCP	030003	NO.3	23.825	50	22	27	45	5	77	81	158	800	4800	0.003
LC-4NCP	030004	NO.4	31.267	66	32	37	55	6.5	98.5	101.5	200	1300	3800	0.003
LC-5NCP	030005	NO.5	44.399	82	40	45	65	6.5	116.5	129.5	246	1900	3400	0.005
LC-6NCP	030006	NO.6	63.384	100	45	65	80	8	153	182	335	2500	3000	0.005

# NCPB-TYPE

※ SHAFT 확장(바이트 간섭 최소화) SHAFT EXTENTION(Minimize the bite-interference)

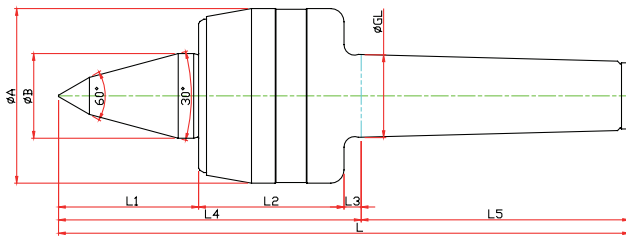

Model	Order Number	Morse Taper	Dimension										Weight MAX.	R.P.M MAX.	Run Out
			GL	A	B	b	L1	L2	L3	L4	L5	L			
LC-3NCPB	031003	NO.3	23.825	50	22	10	27	45	5	97	81	178	410	4800	0.003
LC-4NCPB	031004	NO.4	31.267	66	32	14	37	55	6.5	114.5	101.5	216	710	3800	0.003
LC-5NCPB	031005	NO.5	44.399	82	40	16	45	65	6.5	136.5	129.5	266	1000	3400	0.005
LC-6NCPB	031006	NO.6	63.384	100	45	18	65	80	8	166	182	348	1400	3000	0.005

# NCPC-TYPE

※ 초경타입 Carbide Type

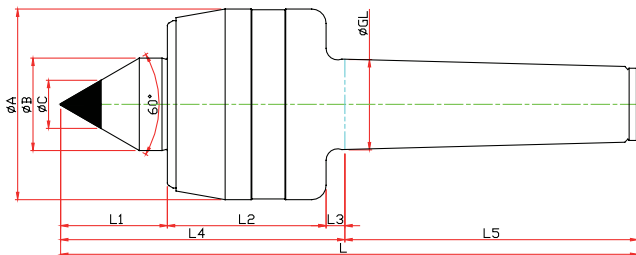

Model	Order Number	Morse Taper	Dimension										Weight MAX.	R.P.M MAX.	Run Out
			GL	A	B	L1	L2	L3	L4	L5	C	L			
LC-3NCPC	030103	NO.3	23.825	50	22	27	45	5	77	81	10	158	800	4800	0.003
LC-4NCPC	030104	NO.4	31.267	66	32	37	55	6.5	98.5	101.5	14	200	1300	3800	0.003
LC-5NCPC	030105	NO.5	44.399	82	40	45	65	6.5	116.5	129.5	18	246	1900	3400	0.005
LC-6NCPC	030106	NO.6	63.384	100	45	65	80	8	153	182	25	335	2500	3000	0.005

# NCPBC-TYPE

- ※ SHAFT 확장(바이트 간섭 최소화) SHAFT EXTENTION(Minimize the bite-interference)
- ※ 초경타입 Carbide Type

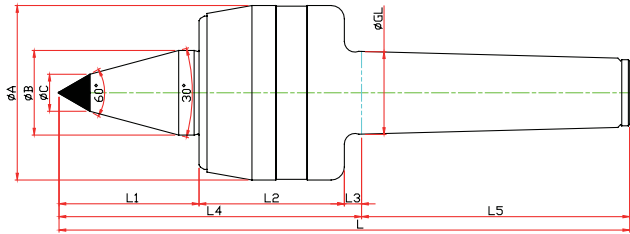

Model	Order Number	Morse Taper	Dimension										Weight MAX.	R.P.M MAX.	Run Out
			GL	A	B	C	L1	L2	L3	L4	L5	L			
LC-3NCPBC	031103	NO.3	23,825	50	22	10	27	45	5	97	81	178	410	4800	0.003
LC-4NCPBC	031104	NO.4	31,267	66	32	14	37	55	6.5	114.5	101.5	216	710	3800	0.003
LC-5NCPBC	031105	NO.5	44,399	82	40	16	45	65	6.5	136.5	129.5	266	1000	3400	0.005
LC-6NCPBC	031106	NO.6	63,384	100	45	18	65	80	8	166	182	348	1400	3000	0.005

# NCPN-TYPE

- ※ 너트타입 Nut Type

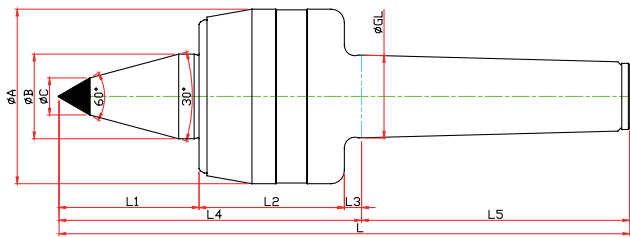

Model	Order Number	Morse Taper	Dimension										Weight MAX.	R.P.M MAX.	Run Out
			GL	A	B	L1	L2	L3	L4	L5	N	L			
LC-3NCPN	030013	NO.3	23,825	50	22	27	45	5	77	81	70	158	800	4800	0.003
LC-4NCPN	030014	NO.4	31,267	66	32	37	55	6.5	98.5	101.5	85	200	1300	3800	0.003
LC-5NCPN	030015	NO.5	44,399	82	40	45	65	6.5	116.5	129.5	105	246	1900	3400	0.005
LC-6NCPN	030016	NO.6	63,384	100	45	65	80	8	153	182	130	335	2500	3000	0.005

# NCPBN-TYPE

- ※ SHAFT 확장(바이트 간섭 최소화) SHAFT EXTENTION(Minimize the bite-interference)
- ※ 너트타입 Nut Type

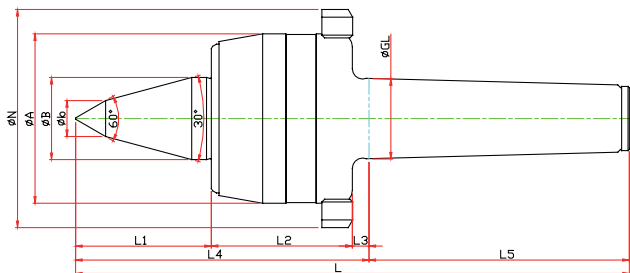

Model	Order Number	Morse Taper	Dimension										Weight MAX.	R.P.M MAX.	Run Out	
			GL	A	B	b	L1	L2	L3	L4	L5	N				L
LC-3NCPBN	031013	NO.3	23,825	50	22	10	47	45	5	97	81	70	178	410	4800	0.003
LC-4NCPBN	031014	NO.4	31,267	66	32	14	53	55	6.5	114.5	101.5	85	216	710	3800	0.003
LC-5NCPBN	031015	NO.5	44,399	82	40	16	65	65	6.5	136.5	129.5	105	266	1000	3400	0.005
LC-6NCPBN	031016	NO.6	63,384	100	45	18	78	80	8	166	182	130	348	1400	3000	0.005



# NCPCN-TYPE

※ 너트, 초경타입 Nut, Carbide Type

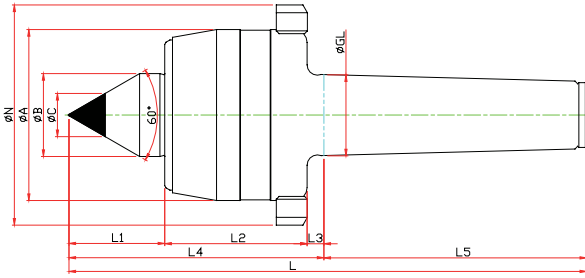

Model	Order Number	Morse Taper	Dimension											Weight MAX.	R.P.M MAX.	Run Out
			GL	A	B	L1	L2	L3	L4	L5	C	N	L			
LC-3NCPCN	030113	NO.3	23,825	50	22	27	45	5	77	81	10	70	158	800	4800	0.003
LC-4NCPCN	030114	NO.4	31,267	66	32	37	55	6.5	98.5	101.5	14	85	200	1300	3800	0.003
LC-5NCPCN	030115	NO.5	44,399	82	40	45	65	6.5	116.5	129.5	18	105	246	1900	3400	0.005
LC-6NCPCN	030116	NO.6	63,384	100	45	65	80	8	153	182	25	130	335	2500	3000	0.005

# NCPBCN-TYPE

※ SHAFT 확장(바이트 간섭 최소화) SHAFT EXTENSION(Minimize the bite-interference)  
 ※ 너트, 초경타입 Nut, Carbide Type

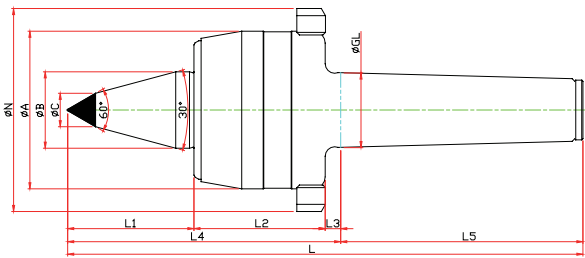

Model	Order Number	Morse Taper	Dimension											Weight MAX.	R.P.M MAX.	Run Out
			GL	A	B	L1	L2	L3	L4	L5	C	N	L			
LC-3NCPBCN	031113	NO.3	23,825	50	22	47	45	5	97	81	10	70	178	800	4800	0.003
LC-4NCPBCN	031114	NO.4	31,267	66	32	53	55	6.5	114.5	101.5	14	85	216	1300	3800	0.003
LC-5NCPBCN	031115	NO.5	44,399	82	40	65	65	6.5	136.5	129.5	16	105	266	1900	3400	0.005
LC-6NCPBCN	031116	NO.6	63,384	100	45	78	80	8	166	182	25	130	348	2500	3000	0.005

# NCP SPECIAL

※ 사용자의 조건에 따라 주문, 제작 Customized-special production for user's condition



NC-TYPE  
 NCP-TYPE  
 NK-NKD TYPE  
 GR-SM TYPE  
 SMP-TYPE  
 D50 TYPE  
 HD-TYPE  
 PT-TYPE  
 LM CENTER  
 LM-H CENTER

## LC-NK

- 고하중물 작업용 센터
- 준 고속형
- 오래가는 센터 수명
- SHAFT 경도 HRC58~62
- RUN OUT 0.003
- 테이퍼 롤러 베어링 사용

- Center for heavy duty
- Semi High Speed
- Long life
- Hardness of SHAFT HRC58~62
- RUN OUT 0.003
- Use Taper Roller Bearing



### NKB TYPE

바이트 간섭 최소화  
Minimize the bite-interference

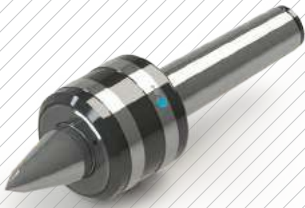

### NKBC TYPE

바이트 간섭 최소화 / 초경타입  
Minimize the bite-interference / Carbide Type



### NKBN TYPE

바이트 간섭 최소화 / 너트타입  
Minimize the bite-interference / Nut Type



### NKBCN TYPE

바이트 간섭 최소화 / 초경, 너트 타입  
Minimize the bite-interference / Carbide, Nut Type



### NKC TYPE

초경타입  
Carbide Type



### NKN TYPE

너트타입  
Nut Type

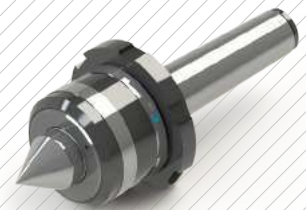

### NKCN TYPE

초경, 너트타입  
Carbide, Nut Type

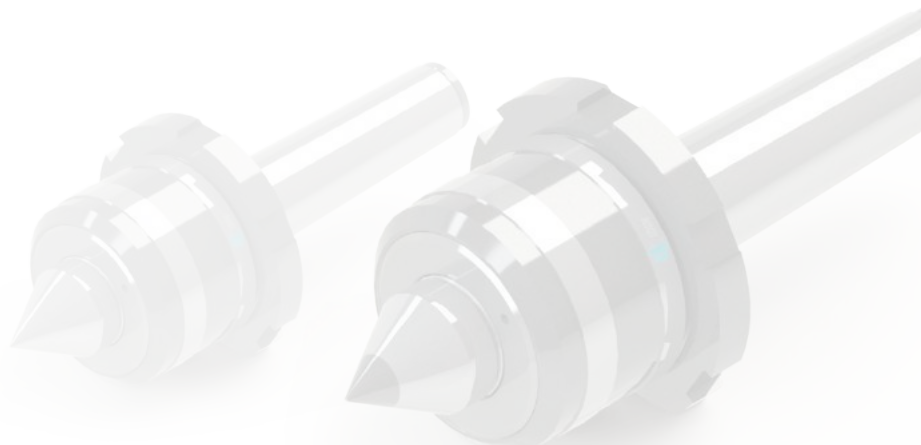

# NK-TYPE

※ 고하중물 전용 센터, 준고속형 Center for heavy duty and Semi High Speed

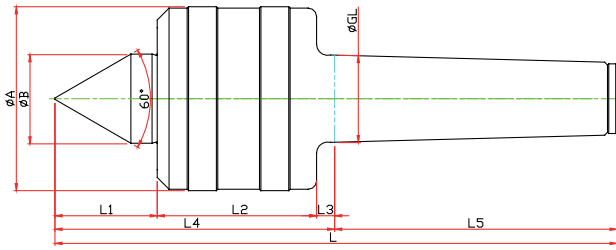

Model	Order Number	Morse Taper	Dimension										Weight MAX.	R.P.M MAX.	Run Out
			GL	A	B	L1	L2	L3	L4	L5	L				
LC-3NK	020003	NO.3	23,825	52	22	29	42	5	76	80	156	1900	5000	0.003	
LC-4NK	020004	NO.4	31,267	66	32	37	57	6.5	100.5	101.5	202	2700	3800	0.003	
LC-5NK	020005	NO.5	44,399	80	40	45.5	57	6.5	109	129.5	238.5	3200	3400	0.005	
LC-6NK	020006	NO.6	63,348	132	65	65	100	8	173	182	355	10000	1800	0.005	
LC-7NK	020007	NO.7	83,058	168	72	84	128	10	222	250	427	17200	1200	0.005	

# NKB-TYPE

※ SHAFT 확장(바이트 간섭 최소화) SHAFT EXTENSION(Minimize the bite-interference)

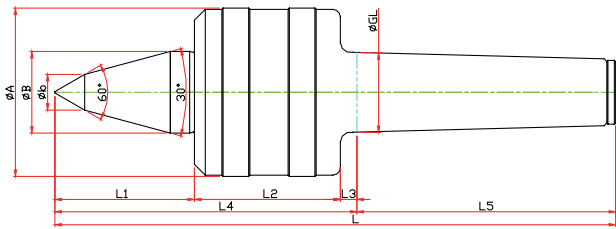

Model	Order Number	Morse Taper	Dimension										Weight MAX.	R.P.M MAX.	Run Out
			GL	A	B	b	L1	L2	L3	L4	L5	L			
LC-3NKB	021003	NO.3	23,825	52	22	10	48	42	5	95	80	175	1900	5000	0.003
LC-4NKB	021004	NO.4	31,267	66	32	14	53	57	6.5	116.5	101.5	218	2700	3800	0.003
LC-5NKB	021005	NO.5	44,399	80	40	18	65.5	57	6.5	129	129.5	258.5	3200	3400	0.005
LC-6NKB	021006	NO.6	63,348	132	65	25	78	100	8	186	182	368	10000	1800	0.005

# NKC-TYPE

※ 초경타입 Carbide Type

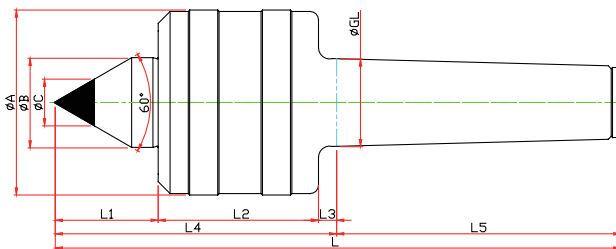

Model	Order Number	Morse Taper	Dimension										Weight MAX.	R.P.M MAX.	Run Out
			GL	A	B	L1	L2	L3	L4	L5	C	L			
LC-3NKC	020103	NO.3	23,825	52	22	29	42	5	76	80	10	156	1900	5000	0.003
LC-4NKC	020104	NO.4	31,267	66	32	37	57	6.5	100.5	101.5	14	202	2700	3800	0.003
LC-5NKC	020105	NO.5	44,399	80	40	45.5	57	6.5	109	129.5	18	238.5	3200	3400	0.005
LC-6NKC	020106	NO.6	63,348	132	65	65	100	8	173	182	25	355	10000	1800	0.005

# NKBC-TYPE

※ SHAFT 확장(바이트 간섭 최소화) SHAFT EXTENSION(Minimize the bite-interference)  
 ※ 초경타입 Carbide Type

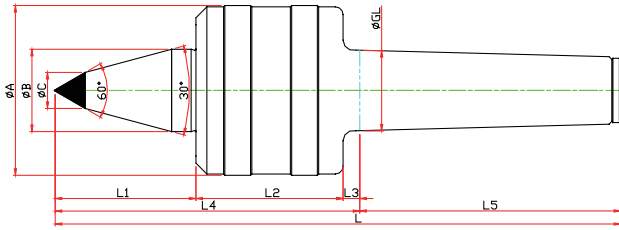

Model	Order Number	Morse Taper	Dimension										Weight MAX.	R.P.M MAX.	Run Out
			GL	A	B	L1	L2	L3	L4	L5	C	L			
LC-3NKBC	021103	NO.3	23,825	52	22	48	42	5	95	80	10	175	1900	5000	0,003
LC-4NKBC	021104	NO.4	31,267	66	32	53	57	6.5	116.5	101.5	14	218	2700	3800	0,003
LC-5NKBC	021105	NO.5	44,399	80	40	65.5	57	6.5	129	129.5	18	258.5	3200	3400	0,005
LC-6NKBC	021106	NO.6	63,348	132	65	78	100	8	186	182	25	368	10000	1800	0,005

# NKN-TYPE

※ 너트, 초경타입 Carbide, Nut Type

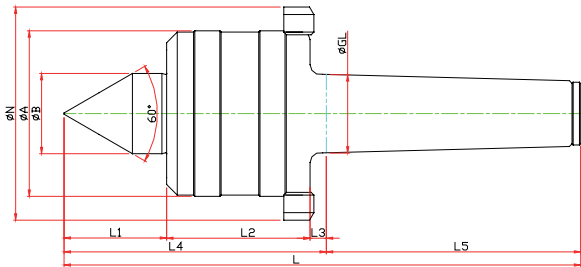

Model	Order Number	Morse Taper	Dimension										Weight MAX.	R.P.M MAX.	Run Out
			GL	A	B	L1	L2	L3	L4	L5	N	L			
LC-3NKN	020013	NO.3	23,825	52	22	29	42	5	76	80	70	156	1900	5000	0,003
LC-4NKN	020014	NO.4	31,267	66	32	37	57	6.5	100.5	101.5	85	202	2700	3800	0,003
LC-5NKN	020015	NO.5	44,399	80	40	45.5	57	6.5	109	129.5	98	238.5	3200	3400	0,005
LC-6NKN	020016	NO.6	63,348	132	65	65	100	8	173	182	165	355	10000	1800	0,005
LC-7NKN	020017	NO.7	83,058	168	72	84	128	10	222	250	210	427	17200	1200	0,005

# NKBN-TYPE

※ SHAFT 확장(바이트 간섭 최소화) SHAFT EXTENSION(Minimize the bite-interference)  
 ※ 너트 타입 Nut Type

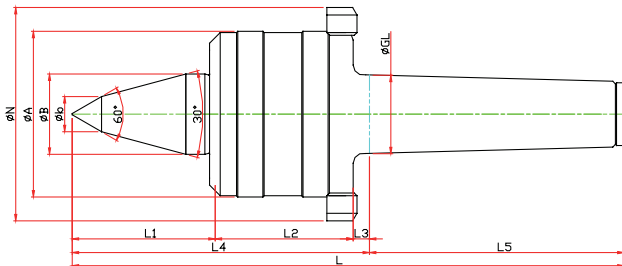

Model	Order Number	Morse Taper	Dimension										Weight MAX.	R.P.M MAX.	Run Out	
			GL	A	B	b	L1	L2	L3	L4	L5	N				L
LC-3NKBN	021013	NO.3	23,825	52	22	10	48	42	5	95	80	70	175	980	5000	0,003
LC-4NKBN	021014	NO.4	31,267	66	32	14	53	57	6.5	116.5	101.5	85	218	1400	3800	0,003
LC-5NKBN	021015	NO.5	44,399	80	40	18	65.5	57	6.5	129	129.5	98	258.5	1900	3400	0,005
LC-6NKBN	021016	NO.6	63,348	132	65	25	78	100	8	186	182	165	368	5100	1800	0,005

# NKCN-TYPE

※ 너트, 초경타입 Carbide, Nut Type

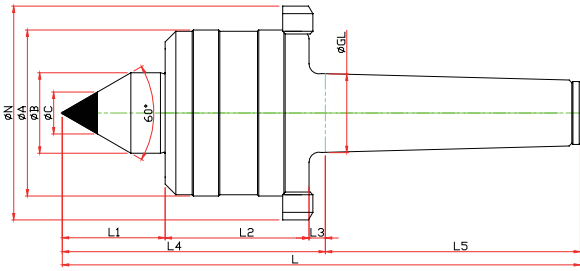

Model	Order Number	Morse Taper	Dimension											Weight MAX.	R.P.M MAX.	Run Out
			GL	A	B	L1	L2	L3	L4	L5	C	N	L			
LC-3NKC	020113	NO.3	23,825	52	22	29	42	5	76	80	10	70	156	1900	5000	0,003
LC-4NKC	020114	NO.4	31,267	66	32	37	57	6.5	100.5	101.5	14	85	202	2700	3800	0,003
LC-5NKC	020115	NO.5	44,399	80	40	45.5	57	6.5	109	129.5	18	98	238.5	3200	3400	0,005
LC-6NKC	020116	NO.6	63,348	132	65	65	100	8	173	182	25	165	355	10000	1800	0,005

# NKBCN-TYPE

※ SHAFT 확장(바이트 간섭 최소화) SHAFT EXTENSION(Minimize the bite-interference)  
 ※ 너트, 초경타입 Carbide, Nut Type

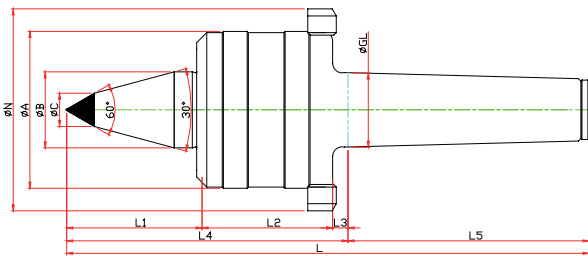

Model	Order Number	Morse Taper	Dimension											Weight MAX.	R.P.M MAX.	Run Out
			GL	A	B	L1	L2	L3	L4	L5	C	N	L			
LC-3NKBC	021113	NO.3	23,825	52	22	48	42	5	95	80	10	70	175	980	5000	0,003
LC-4NKBC	021114	NO.4	31,267	66	32	53	57	6.5	116.5	101.5	14	85	218	1400	3800	0,003
LC-5NKBC	021115	NO.5	44,399	80	40	65.5	57	6.5	129	129.5	18	98	258.5	1900	3400	0,005
LC-6NKBC	021116	NO.6	63,348	132	65	78	100	8	186	182	25	165	368	5100	1800	0,005

NC-TYPE

NCP-TYPE

NK · NKD TYPE

GR · SM TYPE

SMP-TYPE

D50 TYPE

HD-TYPE

PT-TYPE

LM CENTER

LM-H CENTER

# 03

NK · NKD-TYPE

## LC-NKD

- 고하중물 작업용 라이브센터
- 준 고속형
- 수명이 길다
- 테이퍼 롤러 베어링 사용
- SHAFT 열처리경도 HRC58~62
- RUN OUT 0.005
- Live Center for heavy duty
- Semi High Speed
- Long life
- Use Taper Roller Bearing
- Hardness of SHAFT : HRC58~62

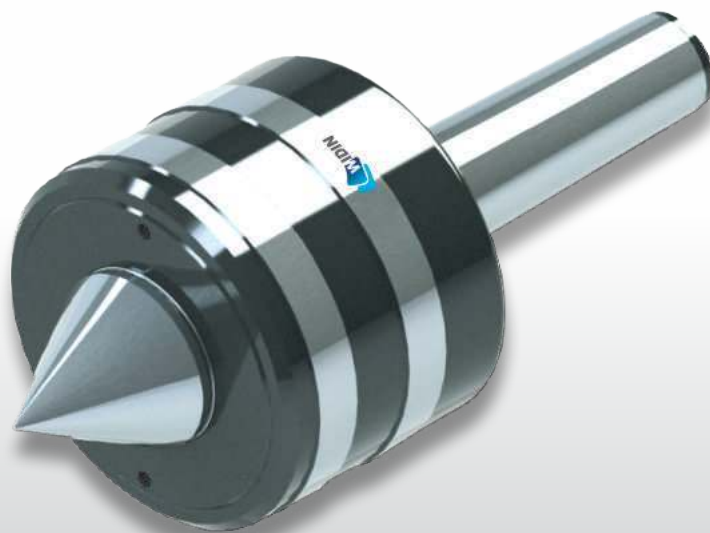

## NKD-TYPE

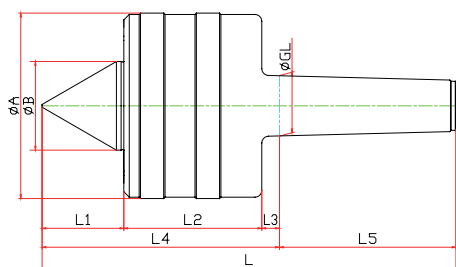

Model	Order Number	Morse Taper	Dimension									Weight MAX.	R.P.M MAX.	Run Out
			GL	A	B	L1	L2	L3	L4	L5	L			
LC-5NKD	090005	NO.5	44,399	136	65	60	101	13	174	129,5	303,5	13000	3400	0,005
LC-6NKD	090006	NO.6	63,348	148	70	80	110,5	15	205,5	181	387,5	16000	1800	0,005
LC-7NKD	090007	NO.7	83,058	200	95	90	141	20	251	250	501	22000	1200	0,005

# 04

GR · SM-TYPE

## LC-GR

- 연마기 전용 라이브센터
- 고정도(0.002), 고하중 지지가능
- Live Center for Grinding machine
- High Precision(0.002) Center for heavy duty



## GR-TYPE

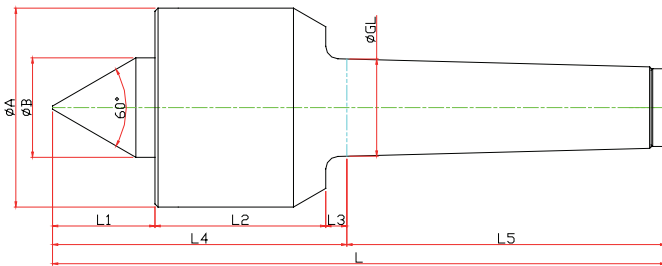

Model	Order Number	Morse Taper	Dimension									Weight MAX.	R.P.M MAX.	Run Out
			GL	A	B	L1	L2	L3	L4	L5	L			
LC-4GR	080004	NO.4	31.267	71	40	45	59.5	6.5	111	101.5	212.5	1300	7000	0.002
LC-5GR	080005	NO.5	44.399	88	50	45	66	6.5	117.5	129.5	247	3500	4500	0.002
LC-6GR	080006	NO.6	63.348	114	52	55	92	8	155	182	337	5000	3400	0.002
LC-7GR	080007	NO.7	83.058	200	98	78	132	10	200	250	470	20000	1900	0.002

# 04

GR · SM-TYPE

## LC-SM

- 고속 회전용 라이브센터
  - 고속 스피들 베어링을 사용
  - SHAFT 경도 HRc58~62
  - RUN OUT 0.003
- Live Center for High Speed Rotation  
· Use High Speed Spindle Bearing  
· Hardness of SHAFT : HRc58~62  
· RUN OUT 0.003



### SMB TYPE

바이트 간섭 최소화  
Minimize the bite-interference



### SMBC TYPE

바이트 간섭 최소화 / 초경타입  
Minimize the bite-interference / Carbide Type

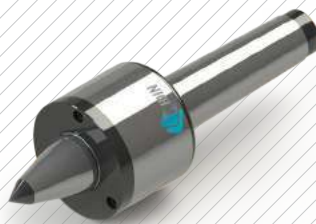

### SMBN TYPE

바이트 간섭 최소화 / 너트타입  
Minimize the bite-interference / Nut Type



### SMBCN TYPE

바이트 간섭 최소화 / 초경, 너트 타입  
Minimize the bite-interference /  
Carbide, Nut Type



### SMC TYPE

초경타입  
Carbide Type

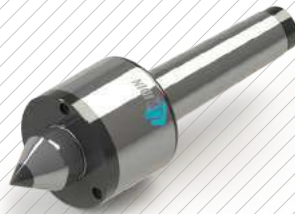

### SMN TYPE

너트타입  
Nut Type



### SMCN TYPE

초경, 너트타입  
Carbide, Nut Type

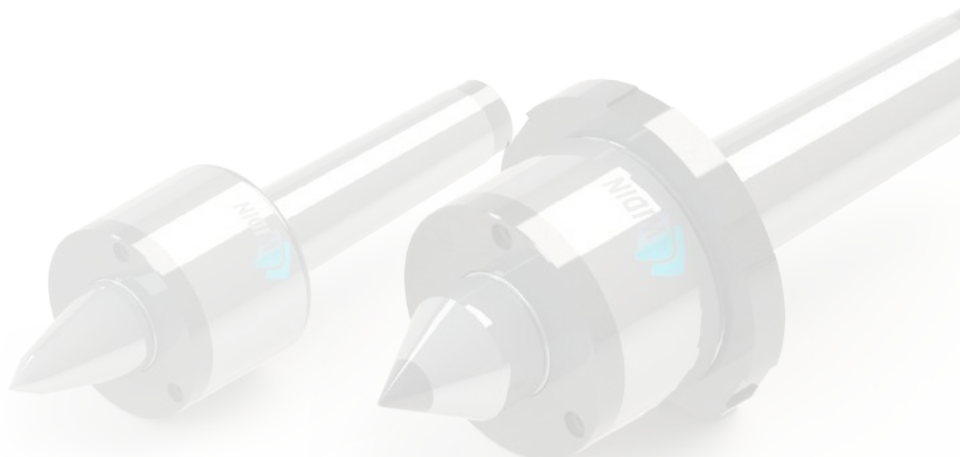



# SM-TYPE

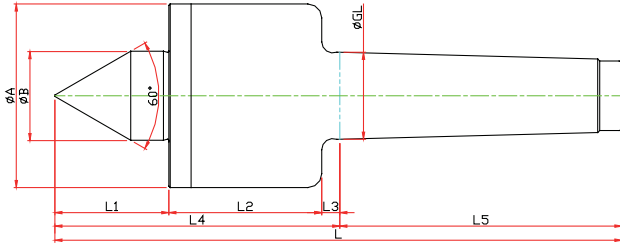

Model	Order Number	Morse Taper	Dimension										Weight MAX.	R.P.M MAX.	Run Out
			GL	A	B	L1	L2	L3	L4	L5	L				
LC-3SM	040003	NO.3	23,825	52	22	30	51	5	86	81	167	330	12000	0,003	
LC-4SM	040004	NO.4	31,267	66	32	41	55	6,5	102,5	101,5	204	1100	10000	0,003	
LC-5SM	040005	NO.5	44,399	82	40	51	75	6,5	132,5	129,5	262	2200	8000	0,005	

# SMB-TYPE

※ SHAFT 확장(바이트 간섭 최소화) SHAFT EXTENTION(Minimize the bite-interference)

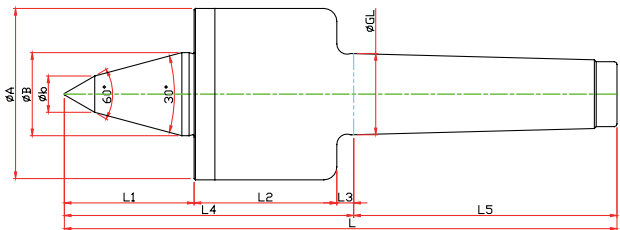

Model	Order Number	Morse Taper	Dimension										Weight MAX.	R.P.M MAX.	Run Out
			GL	A	B	b	L1	L2	L3	L4	L5	L			
LC-3SMB	041003	NO.3	23,825	52	22	10	40	51	5	96	81	177	330	12000	0,003
LC-4SMB	041004	NO.4	31,267	66	32	14	50	55	6,5	111,5	101,5	213	1100	10000	0,003
LC-5SMB	041005	NO.5	44,399	82	40	16	65	75	6,5	146,5	129,5	276	2200	8000	0,005

# SMC-TYPE

※ 초경타입 Carbide Type

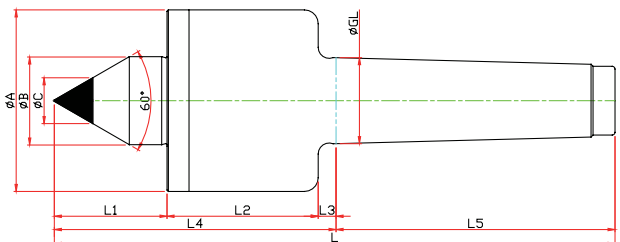

Model	Order Number	Morse Taper	Dimension										Weight MAX.	R.P.M MAX.	Run Out
			GL	A	B	L1	L2	L3	L4	L5	C	L			
LC-3SMC	040103	NO.3	23,825	52	22	30	51	5	86	81	10	167	330	12000	0,003
LC-4SMC	040104	NO.4	31,267	66	32	41	55	6,5	102,5	101,5	14	204	1100	10000	0,003
LC-5SMC	040105	NO.5	44,399	82	40	51	75	6,5	132,5	129,5	18	262	2200	8000	0,005

NC-TYPE

NCP-TYPE

NK · NKD TYPE

GR · SM TYPE

SMP-TYPE

D50 TYPE

HD-TYPE

PT-TYPE

LM CENTER

LM-H CENTER

# SMBC-TYPE

※ SHAFT 확장(바이트 간섭 최소화) SHAFT EXTENSION(Minimize the bite-interference)  
 ※ 초경타입 Carbide Type

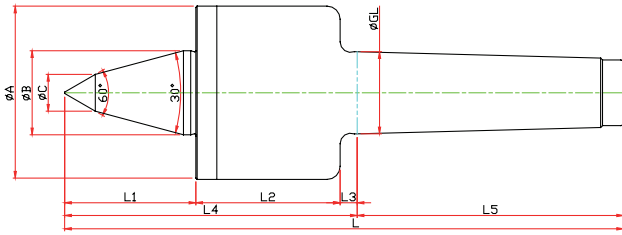

Model	Order Number	Morse Taper	Dimension											Weight MAX.	R.P.M MAX.	Run Out
			GL	A	B	b	L1	L2	L3	L4	L5	C	L			
LC-3SMBC	041103	NO.3	23,825	52	22	10	40	51	5	96	81	10	177	330	12000	0.003
LC-4SMBC	041104	NO.4	31,267	66	32	14	50	55	6.5	111.5	101.5	14	213	1100	10000	0.003
LC-5SMBC	041105	NO.5	44,399	82	40	16	65	75	6.5	146.55	129.5	16	276	2200	8000	0.005

# SMN-TYPE

※ 너트 타입 Nut Type

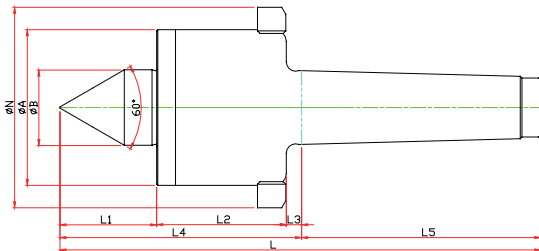

Model	Order Number	Morse Taper	Dimension										Weight MAX.	R.P.M MAX.	Run Out
			GL	A	B	L1	L2	L3	L4	L5	N	L			
LC-3SMN	040013	NO.3	23,825	52	22	30	51	5	86	81	70	167	330	12000	0.003
LC-4SMN	040014	NO.4	31,267	66	32	41	55	6.5	102.5	101.5	85	204	1100	10000	0.003
LC-5SMN	040015	NO.5	44,399	82	40	51	75	6.5	132.5	129.5	105	262	2200	8000	0.005

# SMBN-TYPE

※ SHAFT 확장(바이트 간섭 최소화) SHAFT EXTENSION(Minimize the bite-interference)

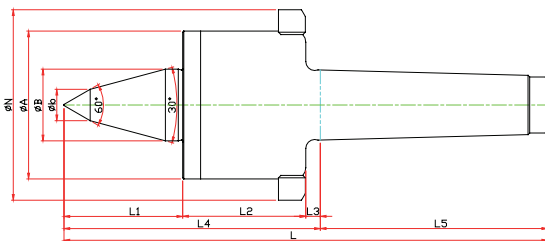

Model	Order Number	Morse Taper	Dimension											Weight MAX.	R.P.M MAX.	Run Out
			GL	A	B	b	L1	L2	L3	L4	L5	N	L			
LC-3SMBN	041013	NO.3	23,825	52	22	10	40	51	5	96	81	70	177	330	12000	0.003
LC-4SMBN	041014	NO.4	31,267	66	32	14	50	55	6.5	111.5	101.5	85	213	1100	10000	0.003
LC-5SMBN	041015	NO.5	44,399	82	40	16	65	75	6.5	146.5	129.5	105	276	2200	8000	0.005

# SMCN-TYPE

※ 너트, 초경타입 Carbide, Nut Type

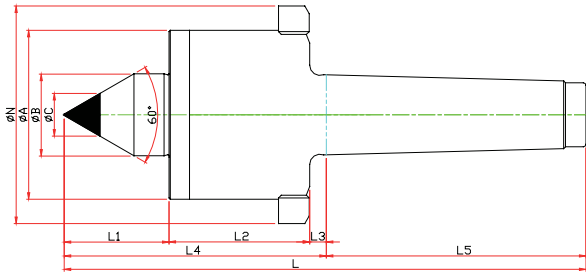

Model	Order Number	Morse Taper	Dimension											Weight MAX.	R.P.M MAX.	Run Out
			GL	A	B	C	D	E	F	G	N	T	L			
LC-3SMCN	040113	NO.3	23,825	52	22	30	51	5	86	81	70	10	167	300	12000	0,003
LC-4SMCN	040114	NO.4	31,267	66	32	41	55	6.5	102.5	101.5	85	14	204	1100	10000	0,003
LC-5SMCN	040115	NO.5	44,399	82	40	51	75	6.5	132.5	129.5	105	16	262	2200	8000	0,005

# SMBCN-TYPE

※ SHAFT 확장(바이트 간섭 최소화) SHAFT EXTENSION(Minimize the bite-interference)  
 ※ 너트, 초경타입 Carbide, Nut Type

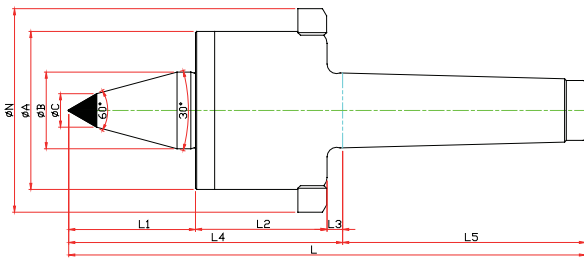

Model	Order Number	Morse Taper	Dimension											Weight MAX.	R.P.M MAX.	Run Out	
			GL	A	B	b	L1	L2	L3	L4	L5	C	N				L
LC-3SMBCN	041113	NO.3	23,825	52	22	10	40	51	5	96	81	10	70	177	330	12000	0,003
LC-4SMBCN	041114	NO.4	31,267	66	32	14	50	55	6.5	111.5	101.5	14	85	213	1100	10000	0,003
LC-5SMBCN	041115	NO.5	44,399	82	40	16	65	75	6.5	146.5	129.5	16	105	276	2200	8000	0,005

## LC-SMP

- 고속 회전용 라이브센터
- 고속 스피들 베어링을 사용
- SM TYPE 보다 강력한 지지력 및 내구성
- SHAFT 경도 HRC58~62
- RUN OUT 0.003

- Live Center for High Speed Rotation
- Use High Speed Spindle Bearing
- Stronger bearing capacity and durability than SM TYPE
- Hardness of SHAFT : HRC58~62
- RUN OUT 0.003

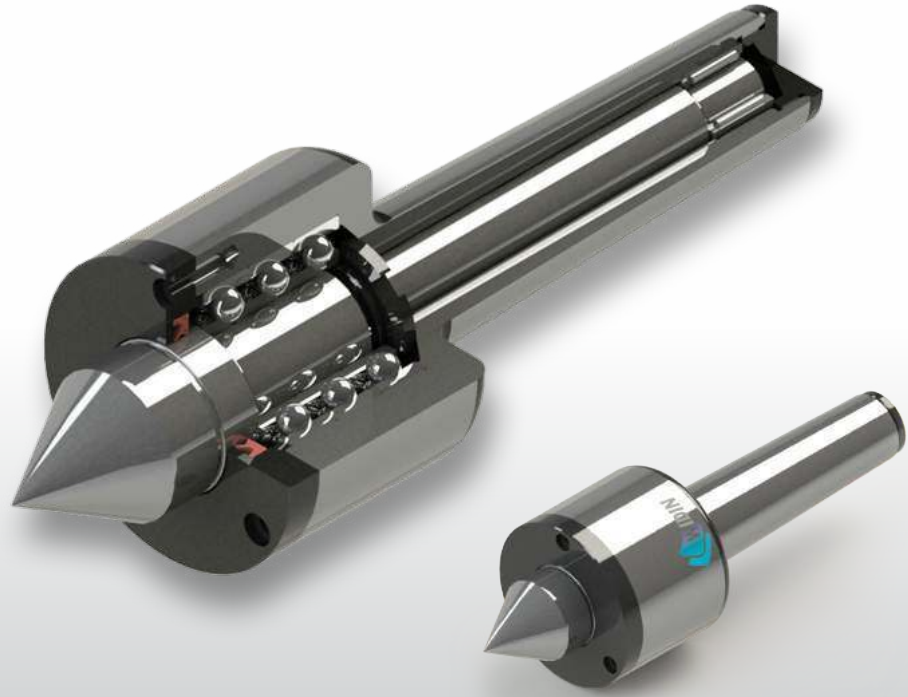

### SMPB TYPE

바이트 간섭 최소화  
Minimize the bite-interference



### SMPBC TYPE

바이트 간섭 최소화 / 초경타입  
Minimize the bite-interference / Carbide Type



### SMPBN TYPE

바이트 간섭 최소화 / 너트타입  
Minimize the bite-interference / Nut Type



### SMPBCN TYPE

바이트 간섭 최소화 / 초경, 너트 타입  
Minimize the bite-interference /  
Carbide, Nut Type



### SMPC TYPE

초경타입  
Carbide Type



### SMPN TYPE

너트타입  
Nut Type



### SMPCN TYPE

초경, 너트타입  
Carbide, Nut Type

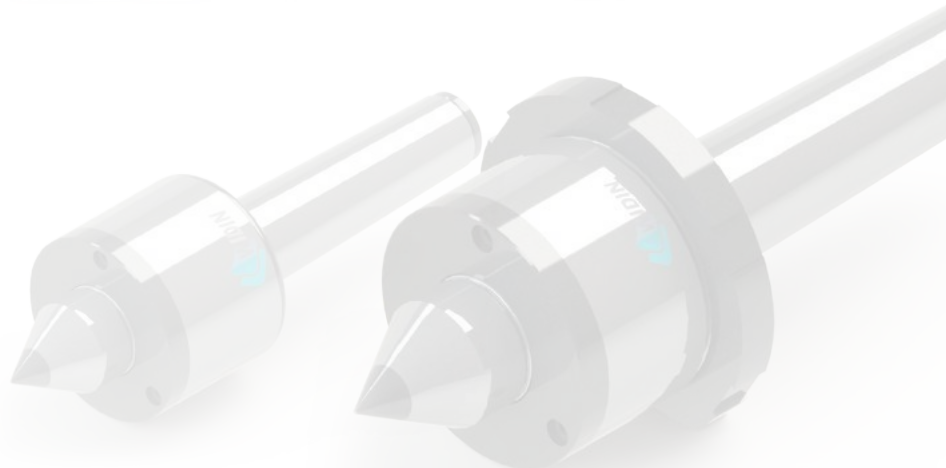

# SMP-TYPE

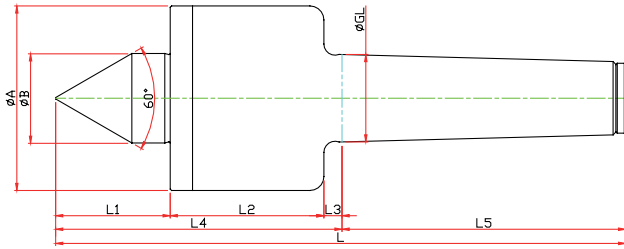

Model	Order Number	Morse Taper	Dimension									Weight MAX.	R.P.M MAX.	Run Out
			GL	A	B	L1	L2	L3	L4	L5	L			
LC-3SMP	050003	NO.3	23.825	52	22	30	51	5	86	81	167	330	12000	0.003
LC-4SMP	050004	NO.4	31.267	66	32	41	55	6.5	102.5	101.5	204	1100	10000	0.003
LC-5SMP	050005	NO.5	44.399	82	40	51	75	6.5	132.5	129.5	262	2200	8000	0.005

# SMPB-TYPE

※ SHAFT 확장(바이트 간섭 최소화) SHAFT EXTENSION(Minimize the bite-interference)

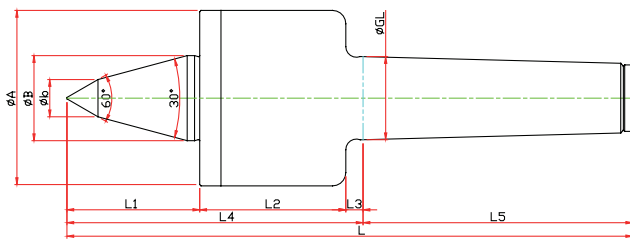

Model	Order Number	Morse Taper	Dimension										Weight MAX.	R.P.M MAX.	Run Out
			GL	A	B	b	L1	L2	L3	L4	L5	L			
LC-3SMPB	051003	NO.3	23.825	52	22	10	40	51	5	96	81	177	330	12000	0.003
LC-4SMPB	051004	NO.4	31.267	66	32	14	50	55	6.5	111.5	101.5	213	1100	10000	0.003
LC-5SMPB	051005	NO.5	44.399	82	40	16	65	75	6.5	146.5	129.5	276	2200	8000	0.005

# SMPC-TYPE

※ 초경타입 Carbide Type

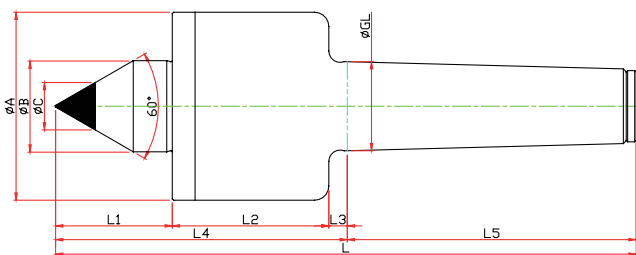

Model	Order Number	Morse Taper	Dimension										Weight MAX.	R.P.M MAX.	Run Out
			GL	A	B	L1	L2	L3	L4	L5	C	L			
LC-3SMPC	050103	NO.3	23.825	52	22	30	51	5	86	81	10	167	330	12000	0.003
LC-4SMPC	050104	NO.4	31.267	66	32	41	55	6.5	102.5	101.5	14	204	1100	10000	0.003
LC-5SMPC	050105	NO.5	44.399	82	40	51	75	6.5	132.5	129.5	18	262	2200	8000	0.005

# SMPBC-TYPE

※ SHAFT 확장(바이트 간섭 최소화) SHAFT EXTENTION(Minimize the bite-interference)  
 ※ 초경타입 Carbide Type

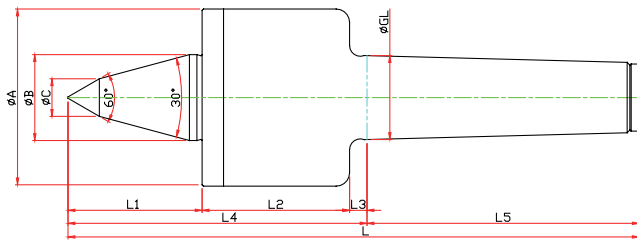

Model	Order Number	Morse Taper	Dimension											Weight MAX.	R.P.M MAX.	Run Out
			GL	A	B	b	L1	L2	L3	L4	L5	C	L			
LC-3SMPBC	051103	NO.3	23.825	52	22	10	40	51	5	96	81	10	177	330	12000	0.003
LC-4SMPBC	051104	NO.4	31.267	66	32	14	50	55	6.5	111.5	101.5	14	213	1100	10000	0.003
LC-5SMPBC	051105	NO.5	44.399	82	40	16	65	75	6.5	146.5	129.5	18	276	2200	8000	0.005

# SMPN-TYPE

※ 너트타입 Nut Type

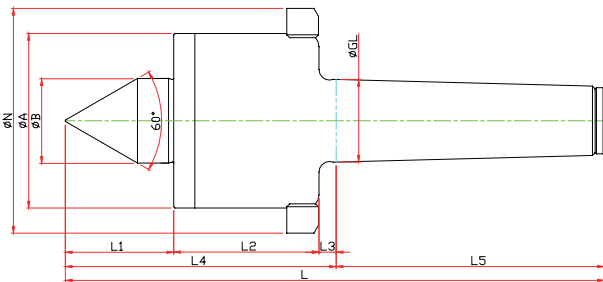

Model	Order Number	Morse Taper	Dimension										Weight MAX.	R.P.M MAX.	Run Out
			GL	A	B	L1	L2	L3	L4	L5	N	L			
LC-3SMPN	050013	NO.3	23.825	52	22	30	51	5	86	81	70	167	330	12000	0.003
LC-4SMPN	050014	NO.4	31.267	66	32	41	55	6.5	102.5	101.5	85	204	1100	10000	0.003
LC-5SMPN	050015	NO.5	44.399	82	40	51	75	6.5	132.5	129.5	105	262	2200	8000	0.005

# SMPBN-TYPE

※ SHAFT 확장(바이트 간섭 최소화) SHAFT EXTENTION(Minimize the bite-interference)  
 ※ 너트타입 Nut Type

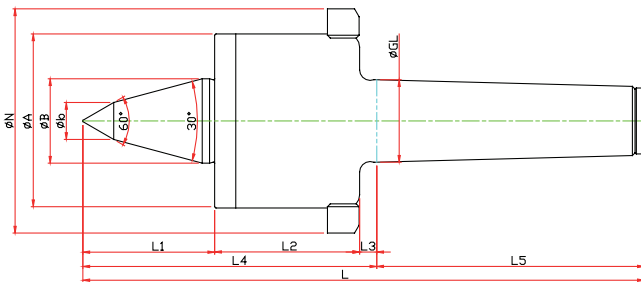

Model	Order Number	Morse Taper	Dimension											Weight MAX.	R.P.M MAX.	Run Out
			GL	A	B	b	L1	L2	L3	L4	L5	N	L			
LC-3SMPBN	051013	NO.3	23.825	52	22	10	40	51	5	96	81	70	177	330	12000	0.003
LC-4SMPBN	051014	NO.4	31.267	66	32	14	50	55	6.5	111.5	101.5	85	213	1100	10000	0.003
LC-5SMPBN	051015	NO.5	44.399	82	40	16	65	75	6.5	146.5	129.5	105	276	2200	8000	0.005

# SMPCN-TYPE

※ 너트, 초경 타입 Nut, Carbide Type

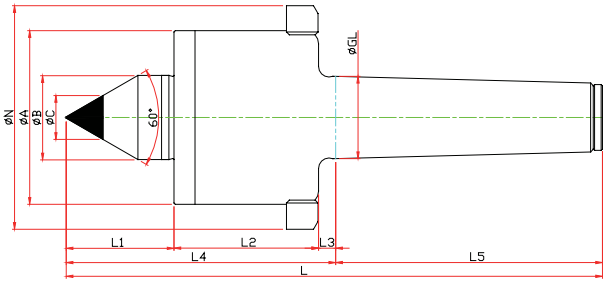

Model	Order Number	Morse Taper	Dimension											Weight MAX.	R.P.M MAX.	Run Out
			GL	A	B	L1	L2	L3	L4	L5	C	N	L			
LC-3SMPCN	050113	NO.3	23,825	52	22	30	51	5	86	81	10	70	167	330	12000	0.003
LC-4SMPCN	050114	NO.4	31,267	66	32	41	55	6.5	102.5	101.5	14	85	204	1100	10000	0.003
LC-5SMPCN	050115	NO.5	44,399	82	40	51	75	6.5	132.5	129.5	18	105	262	2200	8000	0.005

# SMPBCN-TYPE

※ SHAFT 확장(바이트 간섭 최소화) SHAFT EXTENTION(Minimize the bite-interference)  
 ※ 너트, 초경타입 Nut, Carbide Type

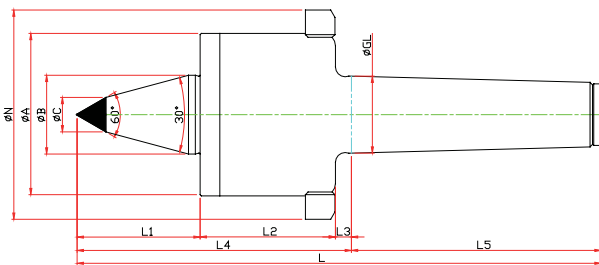

Model	Order Number	Morse Taper	Dimension												Weight MAX.	R.P.M MAX.	Run Out
			GL	A	B	b	L1	L2	L3	L4	L5	C	N	L			
LC-3SMPBCN	051113	NO.3	23,825	52	22	10	40	51	5	96	81	10	70	177	330	12000	0.003
LC-4SMPBCN	051114	NO.4	31,267	66	32	14	50	55	6.5	111.5	101.5	14	85	213	1100	10000	0.003
LC-5SMPBCN	051115	NO.5	44,399	82	40	16	65	75	6.5	146.5	129.5	16	105	276	2200	8000	0.005

# SMP SPECIAL

※ 사용자의 조건에 따라 주문, 제작 Customized-special production for user's condition



NC-TYPE  
 NCP-TYPE  
 NK-NKD TYPE  
 GR-SM TYPE  
 SMP-TYPE  
 D50 TYPE  
 HD-TYPE  
 PT-TYPE  
 LM CENTER  
 LM-H CENTER

## D50-TYPE

- 공구간섭을 최소화한 라이브센터
  - NC선반 사용에 적합
  - 절삭유 및 이물질 유입방지 SEAL 사용
- Minimize the bite-interference
  - Live Center for CNC lathe
  - Seal used to prevent the inflow of cutting oil and foreign substance

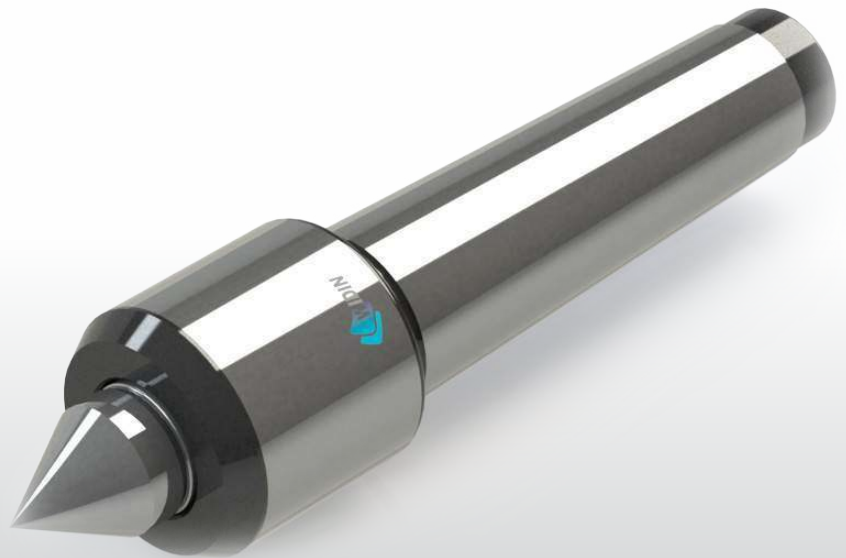

### D50B TYPE

바이트 간섭 최소화  
Minimize the bite-interference



### D50C TYPE

초경타입  
Carbide Type



### D50BC TYPE

바이트 간섭 최소화 / 초경타입  
Minimize the bite-interference / Carbide Type

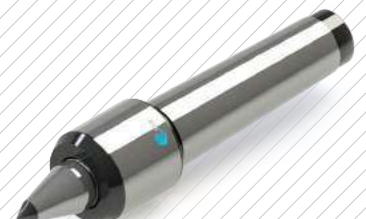



# D50-TYPE

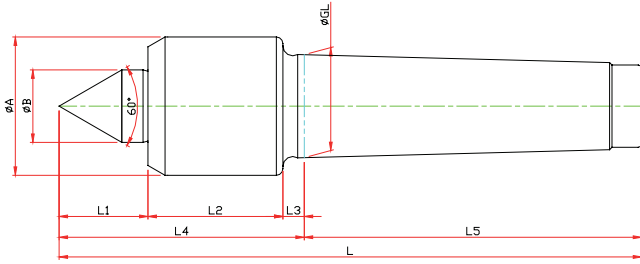

Model	Order Number	Morse Taper	Dimension										Weight MAX.	R.P.M MAX.	Run Out
			GL	A	B	L1	L2	L3	L4	L5	L				
LC-3D50	080350	NO.3	23.825	34	22	21	38	5	64	81	145	400	4800	0.003	
LC-4D50	080450	NO.4	31.267	42	22	27	41	6.5	74.5	102.5	177	800	3800	0.003	
LC-5D50	080550	NO.5	44.399	58	32	35	60	6.5	101.5	129.5	231	1600	3400	0.005	

# D50B-TYPE

※ SHAFT 확장(바이트 간섭 최소화) SHAFT EXTENSION(Minimize the bite-interference)

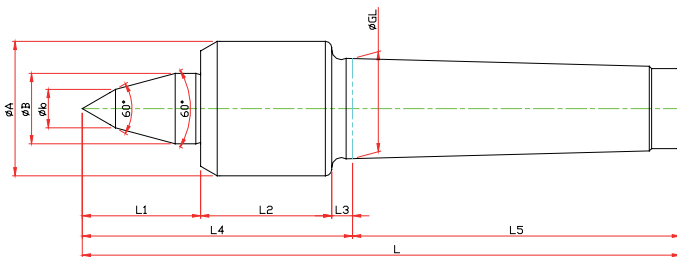

Model	Order Number	Morse Taper	Dimension										Weight MAX.	R.P.M MAX.	Run Out
			GL	A	B	b	L1	L2	L3	L4	L5	L			
LC-3D50B	082350	NO.3	23.825	34	22	10	25	38	5	72	81	153	400	4800	0.003
LC-4D50B	082450	NO.4	31.267	42	22	12	36	41	6.5	83.5	102.5	186.5	800	3800	0.003
LC-5D50B	082550	NO.5	44.399	58	32	16	53	60	6.5	119.5	129.5	249	1600	3400	0.005

# D50C-TYPE

※ 초경 타입 Carbide Type

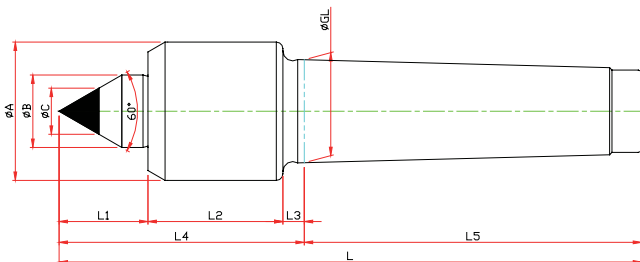

Model	Order Number	Morse Taper	Dimension										Weight MAX.	R.P.M MAX.	Run Out
			GL	A	B	L1	L2	L3	L4	L5	C	L			
LC-3D50C	081350	NO.3	23.825	34	22	21	38	5	64	81	10	145	400	4800	0.003
LC-4D50C	081450	NO.4	31.267	42	22	27	41	6.5	74.5	102.5	14	177	800	3800	0.003
LC-5D50C	081550	NO.5	44.399	58	32	60	60	6.5	101.5	129.5	18	231	1600	3400	0.005

NC-TYPE

NCP-TYPE

NK · NKD TYPE

GR · SM TYPE

SMP-TYPE

D50 TYPE

HD-TYPE

PT-TYPE

LM CENTER

LM-H CENTER

# D50BC-TYPE

※ SHAFT 확장(바이트 간섭 최소화) SHAFT EXTENTION(Minimize the bite-interference)  
 ※ 초경타입 Carbide Type

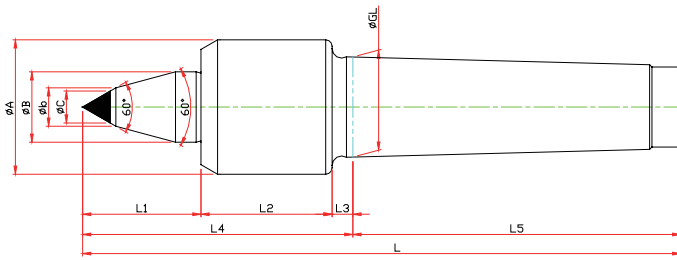

Model	Order Number	Morse Taper	Dimension											Weight MAX.	R.P.M MAX.	Run Out
			GL	A	B	b	L1	L2	L3	L4	L5	C	L			
LC-3D50BC	083350	NO.3	23.825	34	22	10	25	38	5	72	81	8	153	400	4800	0.003
LC-4D50BC	083450	NO.4	31.267	42	22	12	36	41	6.5	83.5	102.5	10	186.5	800	3800	0.003
LC-5D50BC	083550	NO.5	44.399	58	32	16	53	60	6.5	119.5	129.5	14	249	1600	3400	0.005

# D50 SPECIAL

※ 사용자의 조건에 따라 주문, 제작 Customized-special production for user's condition



## HD-TYPE

- 보급형 라이브센터
- 범용 선반사용에 적합
- CAP 회전방식(이물질 유입 방지)

- Economical Live Center
- For Wide-use lathe
- CAP Rotation Type(Prevention of the inflow of foreign substance)



### HDC TYPE

초경타입  
Carbide Type



### HDS TYPE

바이트 간섭을 줄이기 위한 몸체 최소화  
Minimized Body for less bite interference



### HDSC TYPE

바이트 간섭을 줄이기 위한 몸체 최소화  
/ 초경타입  
Minimized Body for less bite interference /  
Carbide Type



### HDSTH TYPE

바이트 간섭 최소화  
Minimize the bite-interference

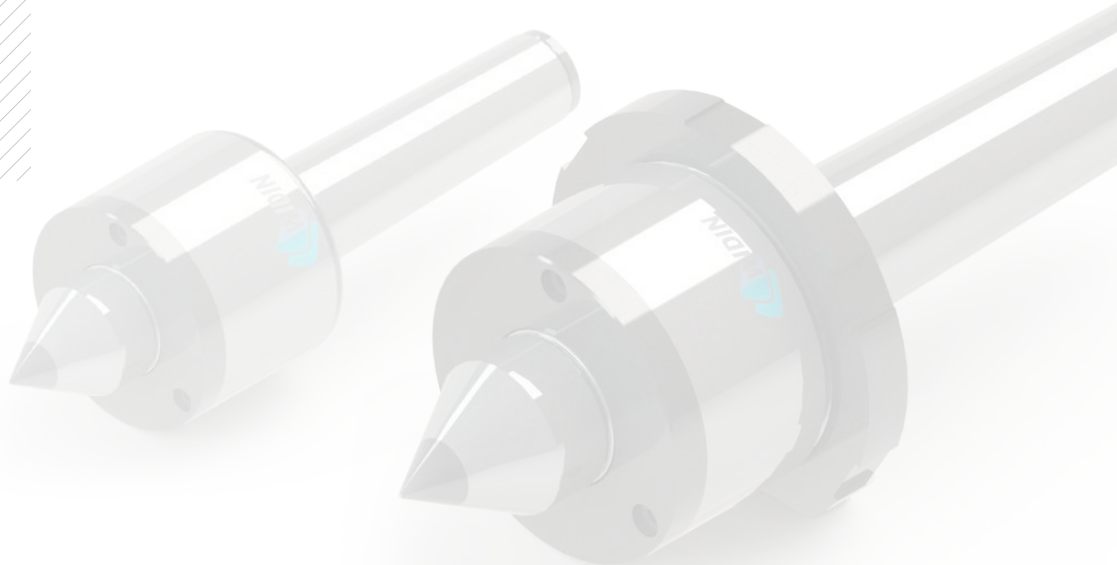

# HD-TYPE

※ 보급형 라이브센터 Economical live center

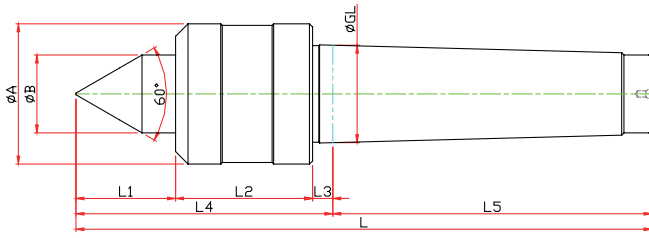

Model	Order Number	Morse Taper	Dimension									Weight MAX.	R.P.M MAX.	Run Out
			GL	A	B	L1	L2	L3	L4	L5	L			
LC-1HD	070001	NO.1	12,065	34	15	21	37	3.5	61.5	53.5	115	120	5000	0.003
LC-2HD	070002	NO.2	17,780	40	18	24	37	5	66	64	130	140	4000	0.003
LC-3HD	070003	NO.3	23,825	45	25	32	44	5	81	81	162	190	3800	0.003
LC-4HD	070004	NO.4	31,267	45	25	32	44	6.5	82.5	102.5	185	190	3800	0.003
LC-5HD	070005	NO.5	44,399	78	38	47	66	6.5	119.5	129.5	249	350	2000	0.005
LC-6HD	070006	NO.6	63,384	102	55	62	82	8	152	182	334	1200	2000	0.005

# HDC-TYPE

※ 초경타입 Carbide Type

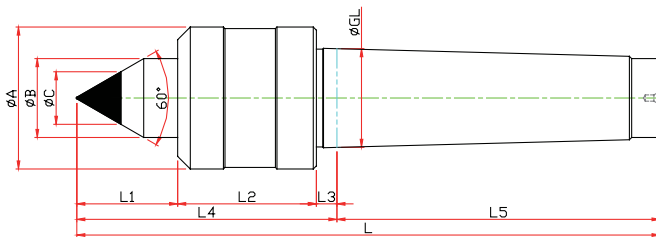

Model	Order Number	Morse Taper	Dimension										Weight MAX.	R.P.M MAX.	Run Out
			GL	A	B	L1	L2	L3	L4	L5	C	L			
LC-3HDC	071003	NO.3	23,825	25	45	32	44	5	81	81	10	162	190	3800	0.003
LC-4HDC	071004	NO.4	31,267	25	45	32	44	6.5	82.5	102.5	14	185	190	3800	0.003
LC-5HDC	071005	NO.5	44,399	38	78	47	66	6.5	119.5	129.5	18	249	350	2000	0.005
LC-6HDC	071006	NO.6	63,384	55	102	62	82	8	152	182	25	334	1200	2000	0.005

# HDS-TYPE

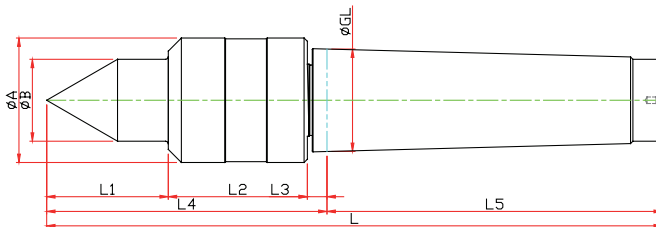

Model	Order Number	Morse Taper	Dimension									Weight MAX.	R.P.M MAX.	Run Out
			GL	A	B	L1	L2	L3	L4	L5	L			
LC-2HDS	070012	NO.2	17,780	34	15	25	40	5	70	64	134	70	4500	0.003
LC-3HDS	070013	NO.3	23,825	36	18	27.5	40.5	5	73	81	154	80	4500	0.003
LC-4HDS	070014	NO.4	31,267	38	22	32	42.5	6	80.5	102.5	183	80	4500	0.003
LC-5HDS	070015	NO.5	44,399	64	30	47	56.5	10	113.5	129.5	243	230	2000	0.005
LC-6HDS	070016	NO.6	63,384	86	42	60	66.5	10	136.5	182	318.5	600	1500	0.005

# HDSC-TYPE

- ※ 보급형 라이브센터 Economical live center
- ※ 범용장비 사용에 적합 Suitable for lathe
- ※ 적정 RPM(3800)이하 Optimal RPM(below 3,800)

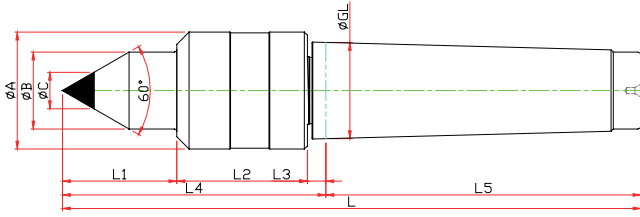

Model	Order Number	Morse Taper	Dimension										Weight MAX.	R.P.M MAX.	Run Out
			GL	A	B	L1	L2	L3	L4	L5	C	L			
LC-3HDSC	071012	NO.3	23,825	36	18	27.5	40.5	5	73	81	10	154	80	4500	0.003
LC-4HDSC	071013	NO.4	31,267	38	22	32	42.5	6	80.5	102.5	14	183	80	4500	0.003
LC-5HDSC	071014	NO.5	44,399	64	30	47	56.5	10	113.5	129.5	18	243	230	2000	0.005
LC-6HDSC	071015	NO.6	63,384	86	42	60	66.5	10	136.5	182	30	318.5	600	1500	0.005

# HDSTH-TYPE

- ※ 나사공전용 타입 The type of thread milling
- ※ 절삭유에 잘 견디는 구조
- ※ 3중 베어링 적합
- ※ 적정 RPM(3800)이하 Optimal RPM(below 3,800)

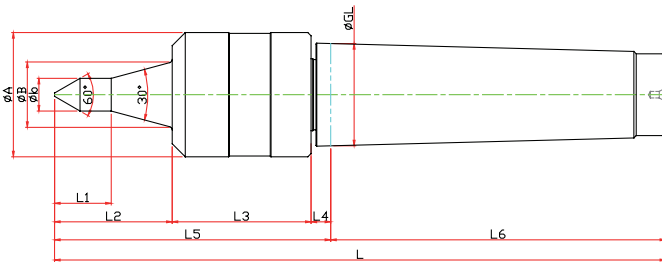

Model	Order Number	Morse Taper	Dimension											Weight MAX.	R.P.M MAX.	Run Out
			GL	A	B	b	L1	L2	L3	L4	L5	L6	L			
LC-3HDSTH-06	073011	NO.3	23,825	36	18	6	12.6	35	40.5	5	80.5	81	161.5	55	3800	0.003
LC-3HDSTH-08	073012					8	16.3									
LC-3HDSTH-10	073013					10	20.1									
LC-3HDSTH-12	073014					12	23.8									
LC-4HDSTH-06	074011	NO.4	31,267	38	20	6	10.1	36.2	40.5	6	84.5	102.5	187	65	3800	0.003
LC-4HDSTH-08	074012					8	13.9									
LC-4HDSTH-10	074013					10	17.6									
LC-4HDSTH-12	074014					12	21.3									
LC-5HDSTH-06	075011	NO.5	44,399	64	24	6	13.4	47	56.5	10	113.5	129.5	243	150	3800	0.003
LC-5HDSTH-08	075012					8	17.1									
LC-5HDSTH-10	075013					10	20.8									
LC-4HDSTH-12	075014					12	24.6									

# HD SPECIAL



# 08

## PT-TYPE

- PIPE 가공 전용
- 적정 RPM(3800이하)
- For PIPE machining
- Optimal RPM(below 3,800)



### PT-60 TYPE

PIPE 가공 전용 For PIPE machining  
적정 RPM(3800)이하 Optimal RPM(below 3,800)



### PT-80 TYPE

PIPE 가공 전용 For PIPE machining  
적정 RPM(3800)이하 Optimal RPM(below 3,800)



# PT-60 TYPE

※ PIPE 가공 전용 For PIPE machining  
 ※ 적정 RPM(3800이하) Optimal RPM(below 3,800)

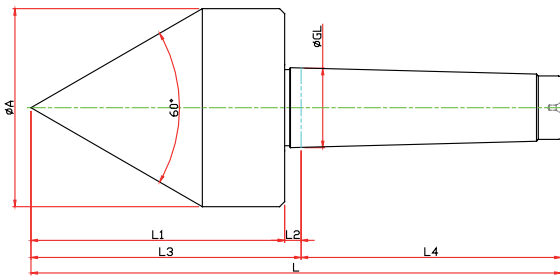

Model	Order Number	Morse Taper	Dimension							Weight MAX.	R.P.M MAX.	Run Out
			GL	A	L1	L2	L3	L4	L			
LC-2PT-60	066002	NO.2	17,780	44	66	5	71	64	135	70	4500	0.003
LC-3PT-60	066003	NO.3	23,825	56	78.5	5	83.5	81	164.5	80	4500	0.003
LC-4PT-60	066004	NO.4	31,267	78	100	6.5	106.5	101.5	208	80	4500	0.003
LC-5PT-60	066005	NO.5	44,399	98	125	6.5	131.5	129.5	261	230	2000	0.005
LC-6PT-60	066006	NO.6	63,384	118	154	8	162	182	344	600	1500	0.005

# PT-80 TYPE

※ PIPE 가공 전용 For PIPE machining  
 ※ 적정 RPM(3800이하) Optimal RPM(below 3,800)

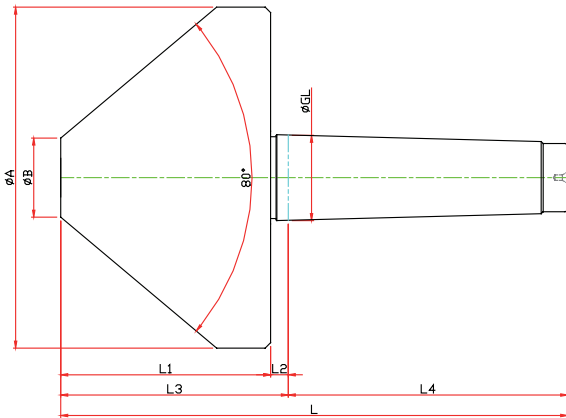

Model	Order Number	Morse Taper	Dimension								Weight MAX.	R.P.M MAX.	Run Out
			GL	A	B	L1	L2	L3	L4	L			
LC-3PT-80	068003	NO.3	23,825	95	20	66	5	65	81	146	190	3800	0.003
LC-4PT-80	068004	NO.4	31,267	125	29	77	6.5	83.5	102.5	185	190	3800	0.003
LC-5PT-80	068005	NO.5	44,399	150	32	90	6.5	96.5	129.5	226	350	2000	0.005
LC-6PT-80	068006	NO.6	63,384	200	38	120	8	128	182	310	1200	1500	0.005

## LM CENTER

● 고정센터

· Dead Center



### LM-C TYPE

초경타입  
Carbide Type



### LM-AN TYPE

너트타입  
Nut Type



### LM-CN TYPE

초경타입, 너트타입  
Carbide Type, Nut Type





# LM-A TYPE

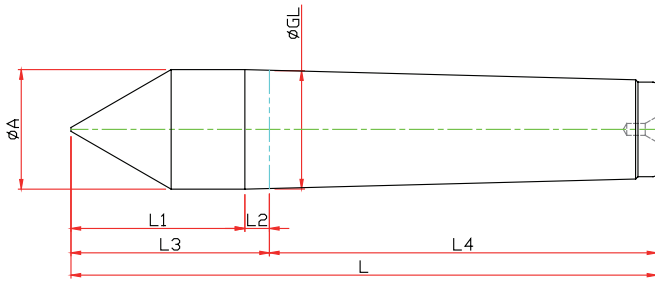

Model	Order Number	Morse Taper	Dimension							Run Out
			GL	A	L1	L2	L3	L4	L	
LM-1A	110001	NO.1	12,065	12,2	25	3,5	28,5	53,5	82	0,003
LM-2A	110002	NO.2	17,780	18	31	5	36	64	100	0,003
LM-3A	110003	NO.3	23,825	24	39	5	44	81	125	0,003
LM-4A	110004	NO.4	31,267	31,6	46	6,5	52,5	102,5	155	0,003
LM-5A	110005	NO.5	44,399	44,7	64	6,5	70,5	129,5	200	0,003
LM-6A	110006	NO.6	63,348	63,8	80	8	88	182	270	0,005
LM-7A	110007	NO.7	83,058	83,6	105	10	115	250	365	0,005

# LM-C TYPE

※ 초경타입 Carbide Type

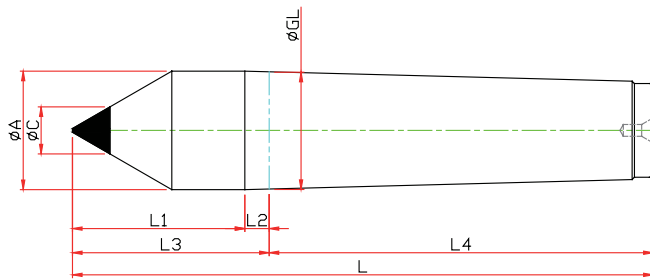

Model	Order Number	Morse Taper	Dimension								Run Out
			GL	A	L1	L2	L3	L4	C	L	
LM-1C	110101	NO.1	12,065	12,2	25	3,5	28,5	53,5	7	82	0,003
LM-2C	110102	NO.2	17,780	18	31	5	36	64	7	100	0,003
LM-3C	110103	NO.3	23,825	24	39	5	44	81	10	125	0,003
LM-4C	110104	NO.4	31,267	31,6	46	6,5	52,5	102,5	14	155	0,003
LM-5C	110105	NO.5	44,399	44,7	64	6,5	70,5	129,5	18	200	0,003
LM-6C	110106	NO.6	63,348	63,8	80	8	88	182	25	270	0,005
LM-7C	110107	NO.7	83,058	83,6	105	10	115	250	30	365	0,005

# LM-AN TYPE

※ 너트타입 Nut Type

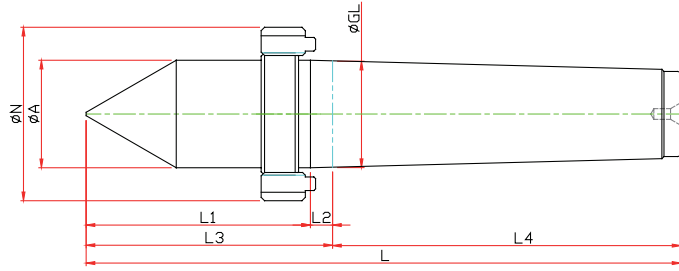

Model	Order Number	Morse Taper	Dimension								Run Out
			GL	A	L1	L2	L3	L4	N	L	
LM-1AN	110011	NO.1	12,065	12.2	31.5	5	36.5	53.5	M16	90	0.003
LM-2AN	110012	NO.2	17,780	18	41.5	6.5	48	64	M22	112	0.003
LM-3AN	110013	NO.3	23,825	24	49.5	7.5	57	81	M27	138	0.003
LM-4AN	110014	NO.4	31,267	31.6	62.5	10	72.5	102.5	M36	175	0.003
LM-5AN	110015	NO.5	44,399	44.7	77	11	88	129.6	M48	217.5	0.003
LM-6AN	110016	NO.6	63,348	63.8	96.5	11.5	108	182	M68	290	0.005
LM-7AN	110017	NO.7	83,058	83.6	108.5	11.5	120	250	M90	370	0.005

# LM-CN TYPE

※ 초경타입, 너트타입 Carbide, Nut Type

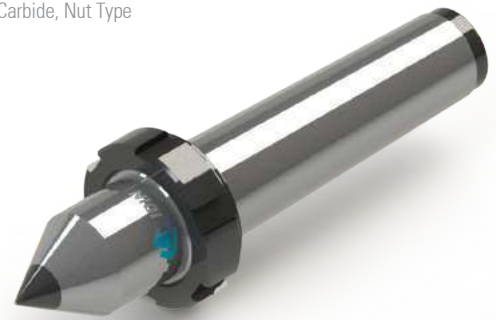
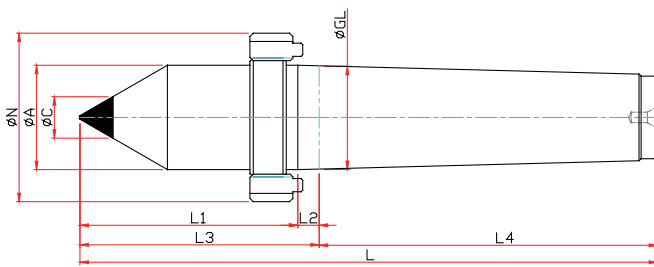

Model	Order Number	Morse Taper	Dimension									Run Out
			GL	A	L1	L2	L3	L4	C	N	L	
LM-1CN	110111	NO.1	12,065	12	31.5	5	36.5	53.5	7	M16	90	0.003
LM-2CN	110112	NO.2	17,780	18	41.5	6.5	48	64	7	M22	112	0.003
LM-3CN	110113	NO.3	23,825	24	49.5	7.5	57	81	10	M27	138	0.003
LM-4CN	110114	NO.4	31,267	32	62.5	10	72.5	102.5	14	M36	175	0.003
LM-5CN	110115	NO.5	44,399	45	77	11	88	129.5	18	M48	217.5	0.003
LM-6CN	110116	NO.6	63,348	64	96.5	11.5	108	182	18	M68	290	0.005

# LM SPECIAL

※ 사용자의 조건에 따라 주문. 제작 Customized-special production for user's condition



# 10

## LM-H CENTER

- 하프센터
- 연마석 바이트 간섭 최소화
- Half Center
- Minimize the bite interference of grindstone



### LM-HC TYPE

연마석 바이트 간섭 최소화 / 초경타입  
Minimize the bite interference of grindstone /  
Carbide Type



### LM-HN TYPE

연마석 바이트 간섭 최소화 / 너트타입  
Minimize the bite interference of grindstone /  
Nut Type



### LM-HCN TYPE

연마석 바이트 간섭 최소화 / 너트타입  
Minimize the bite interference of grindstone /  
Nut Type



## LM-H TYPE

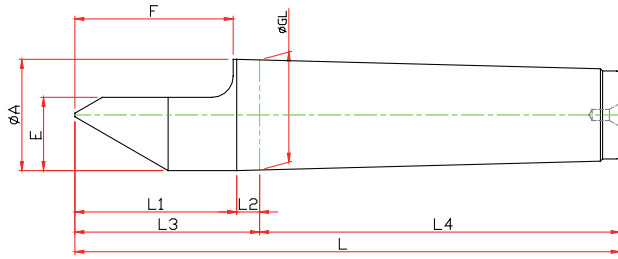

Model	Order Number	Morse Taper	Dimension									Run Out
			GL	A	L1	L2	L3	L4	E	F	L	
LM-1H	210001	NO.1	12,065	12,2	25	3,5	28,5	53,5	7,6	22	82	0,003
LM-2H	210002	NO.2	17,780	18	31	5	36	64	11	30	100	0,003
LM-3H	210003	NO.3	23,825	24	39	5	44	81	15	38	125	0,003
LM-4H	210004	NO.4	31,267	31,6	46	6,5	52,5	102,5	21	45	155	0,003
LM-5H	210005	NO.5	44,399	44,7	64	6,5	70,5	129,5	27,4	63	200	0,003
LM-6H	210006	NO.6	63,348	63,8	80	8	88	182	38,9	79	270	0,005

## LM-HC TYPE

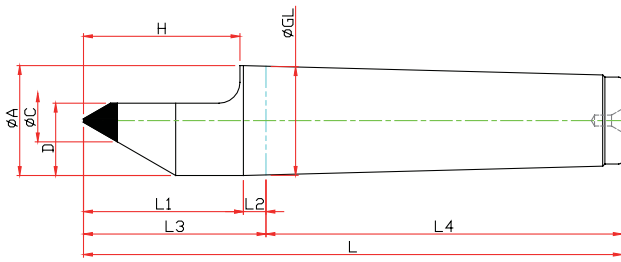

Model	Order Number	Morse Taper	Dimension										Run Out
			GL	A	L1	L2	L3	L4	C	D	H	L	
LM-1HC	210101	NO.1	12,065	12,2	25	3,5	28,5	53,5	7	7,6	22	82	0,003
LM-2HC	210102	NO.2	17,780	18	31	5	36	64	7	11	30	100	0,003
LM-3HC	210103	NO.3	23,825	24	39	5	44	81	10	15	38	125	0,003
LM-4HC	210104	NO.4	31,267	31,6	46	6,5	52,5	102,5	14	21	45	125	0,003
LM-5HC	210105	NO.5	44,399	44,7	64	6,5	70,5	129,5	18	27,4	63	200	0,003
LM-6HC	210106	NO.6	63,348	63,8	80	8	88	182	25	38,9	79	270	0,005

# LM-HN TYPE

※ 너트타입 Nut Type

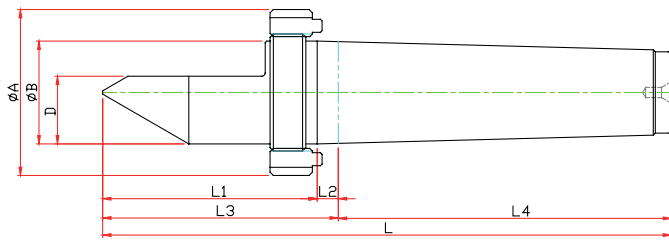

Model	Order Number	Morse Taper	Dimension										Run Out
			GL	A	L1	L2	L3	L4	D	E	N	L	
LM-1HN	210011	NO.1	12,065	12	31.5	5	36.5	53.5	7.6	22	M16	90	0.003
LM-2HN	210012	NO.2	17,780	18	41.5	6.5	48	64	11	30	M22	112	0.003
LM-3HN	210013	NO.3	23,825	24	49.5	7.5	57	81	15	38	M27	138	0.003
LM-4HN	210014	NO.4	31,267	32	62.5	10	72.5	102.5	21	50	M36	175	0.003
LM-5HN	210015	NO.5	44,399	45	77	11	88	129.5	29.4	63	M48	217.5	0.003
LM-6HN	210016	NO.6	63,348	64	96.5	11.5	108	182	42	79	M68	290	0.005

# LM-HCN TYPE

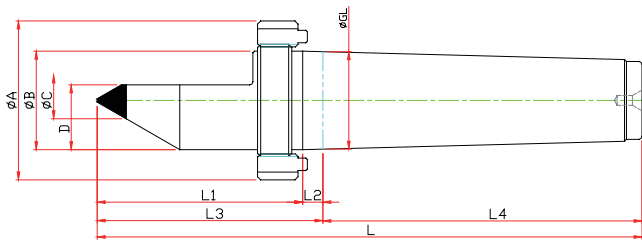

Model	Order Number	Morse Taper	Dimension											Run Out
			GL	A	L1	L2	L3	L4	C	D	E	N	L	
LM-1HCN	210111	NO.1	12,065	12	31.5	5	36.5	53.5	7	7.6	22	M16	90	0.003
LM-2HCN	210112	NO.2	17,780	18	41.5	6.5	48	64	7	11	30	M22	112	0.003
LM-3HCN	210113	NO.3	23,825	24	49.5	7.5	57	81	10	15	38	M27	138	0.003
LM-4HCN	210114	NO.4	31,267	32	62.5	10	72.5	102.5	14	21	50	M36	175	0.003
LM-5HCN	210115	NO.5	44,399	45	77	11	88	129.5	18	29.4	63	M48	217.5	0.003
LM-6HCN	210116	NO.6	63,348	64	96.5	11.5	108	182	18	42	79	M68	290	0.005

# LM-H SPECIAL

※ 사용자의 조건에 따라 주문. 제작 Customized-special production for user's condition



# 11

## LM-FN CENTER

- 스패너 타입 고정센터
- Spanner Type Dead Center



### LM-FN TYPE

※ 스패너 타입 Spanner Type

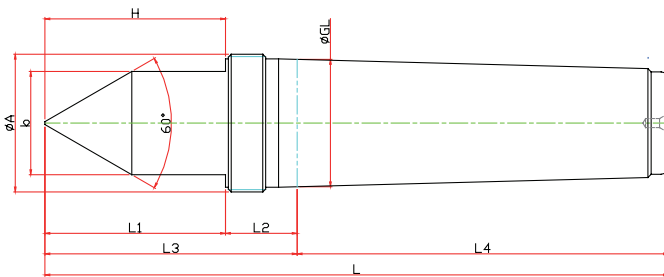

Model	Order Number	Morse Taper	Dimension									Run Out
			GL	A	b	L1	L2	L3	L4	E	L	
LM-1FN	120011	NO.1	12,065	12.2	10	25	3.5	28.5	53.5	22	82	0.003
LM-2FN	120012	NO.2	17,780	18	14	31	5	36	64	30	100	0.003
LM-3FN	120013	NO.3	23,825	24	19	39	5	44	81	38	125	0.003
LM-4FN	120014	NO.4	31,267	31.6	27	46	6.5	52.5	102.5	50	155	0.003
LM-5FN	120015	NO.5	44,399	44.7	36	64	6.5	70.5	129.5	53	200	0.003

# 12

## LM-#80 TYPE

- 1/10 TAPER 고정센터
  - 너트 탈부착형
- 1/10 TAPER Dead Center  
· Detachable Nut

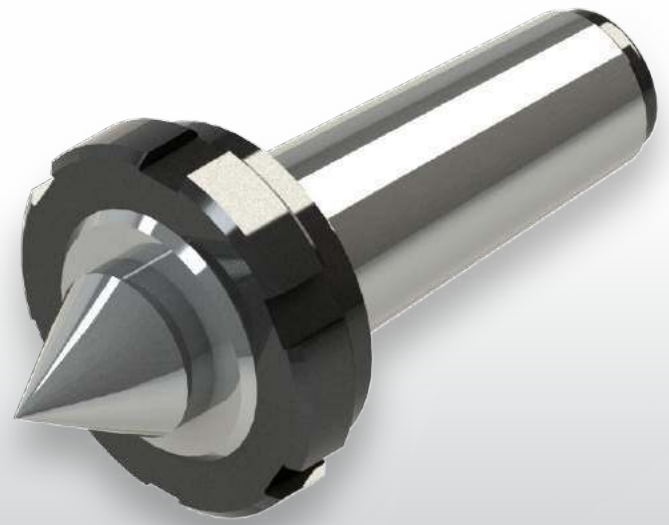

## LM-#80 TYPE

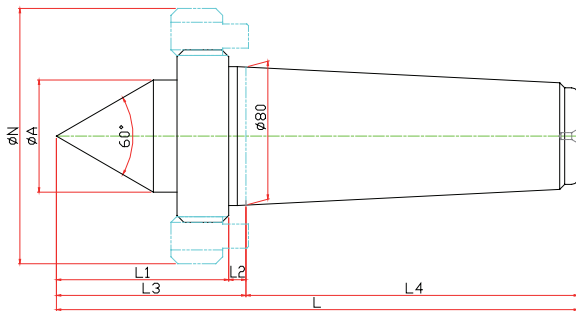

Model	Order Number	Morse Taper	Dimension									Run Out
			GL	A	b	L1	L2	L3	L4	E	L	
#80-60	260010	1/10 TAPER	80	65	148	70	30	10	110	193	303	0.005
#80-75	275010	1/10 TAPER	80	65	148	70	30	10	110	193	303	0.005

# LIVE CENTER

LIVE CENTER / LATHE CENTER / SPECIAL LIVE CENTER



**본사&창원공장** 경상남도 창원시 의창구 사화로 172 (팔용동) [51389]  
TEL. 055-286-0905 / FAX. 055-286-0978

**시카고 지사** TEL. 1-847-947-8320 / FAX. 1-847-947-8322

**상하이 지사** TEL. 86-21-5831-8103 / FAX. 86-21-5831-8153

**베트남 지사(하노이)** TEL. 84-4-6287-3839 / FAX. 84-4-6287-3828

**베트남 지사(호치민)** TEL. 84-8-2253-1117 / FAX. 84-4-6287-3828

**서울영업소** 서울특별시 구로구 구로중앙로198 (구로동) 공구상가 C블록 20동 109호 [08212]  
TEL. 02-2679-0980 / FAX. 02-2679-0970

**시화영업소** 경기도 시흥시 공단1대로 244 (정왕동) 시화유통상가 19-108 [15103]  
TEL. 031-430-5446 / FAX. 031-430-5579

**대구영업소** 대구광역시 북구 산격동 1629번지 산업용재판 13동 31호 [41518]  
TEL. 053-604-0968 / FAX. 053-604-0932

**부산영업소** 부산광역시 사상구 과감로 37 (괘법동) 산업용품유통상가 15-105호 [46977]  
TEL. 051-319-0914 / FAX. 051-319-0976

**광주영업소** 광주광역시 광산구 하남산단 4번로 168(장덕동) 남5호, 6호 [62227]  
TEL. 062-961-0985 / FAX. 062-961-0982

**창원영업소** 경상남도 창원시 의창구 창원대로 390 (팔용동) 위딘 B.D 102호 [51401]  
TEL. 055-277-9911 / FAX. 055-237-0904

## Head office & Changwon Factory

172, Sahwa-ro, Uichang-gu, Changwon-si, Gyeongsangnam-do, Korea [51389]  
TEL. 82-55-286-0905 FAX. 82-55-286-0978

## Chicago Office(WIDIN. INC.)

1801 Hicks Rd, Unit B Rolling Meadow il 60008  
TEL. 1-847-947-8320 FAX. 1-847-947-8322

## Shanghai Office(WIDIN Shanghai Trade Co.,Ltd.)

#303, NO 6818-10, Zhong Chun RD Min Hang District, Shanghai, China 201101  
TEL. 86-21-5831-8103 FAX. 86-21-5831-8153

## Vietnam Honoi Office(WIDIN VINA Co.,Ltd.)

Room A308, 3rd floor, The Manor Tower, Me Tri Rd, My Dinh Ward, Nam Tu Liem Dist, Hanoi, Vietnam  
TEL. 84-4-6287-3839 FAX. 84-4-6287-3828

## Vietnam Ho Chi Minh Office(WIDIN VINA Co.,Ltd.)

R 402, Ben Thanh Tourist Building 1, 79 Nguyen Trai St., Ben Thanh Ward, HCMC, Vietnam  
TEL. 84-8-2253-1117 FAX. 84-4-6287-3828