

HIGH-PERFORMANCE



株洲精工硬质合金有限公司
ZHUSHOU JINGGONG CEMENTED CARBIDE CO., LTD.

地址：湖南省株洲市天元区新马工业园新马南路335号
ADD: No.335, Xinma South Road, Xinma Industrial Park, Tianyuan District, Zhuzhou, Hunan, China.

电话(国内): 0731-22896707 22896717 22896758
TEL(Domestic): 0731-22896707 22896717 22896758
电话(国际): 86-731-22896701
TEL(International): 86-731-22896701
Http://www.jgcarbide.com
E-mail(国内): jgcarbide@163.com
E-mail(Domestic): jgcarbide@163.com
E-mail(国际): zzjg@vip.163.com
E-mail(International): zzjg@vip.163.com



精工硬质合金
JINGGONG CEMENTED CARBIDE
— 精于业 · 工其事 —

切削刀具

CUTTING TOOLS

2023-2024

- 车削刀具
Turning Tools
- 铣削刀具
Milling Tools
- 孔加工刀具
Hole Machining Tools
- 整硬刀具
Solid Carbide Cutting Tools



株洲精工硬质合金有限公司
ZHUSHOU JINGGONG CEMENTED CARBIDE CO., LTD.

公司简介

COMPANY PROFILE

株洲精工硬质合金有限公司成立于2001年5月，公司位于株洲市国家级高新技术开发区，是一家集硬质合金研发、生产、销售为一体的高科技股份制企业。公司主要生产切削刀具、锯齿片、地质矿山工具、模具材料、棒材、非标异型等产品。广泛应用于模具行业，汽车行业，轨道交通，工程机械，3C行业，航天航空，能源装备，通用机械，石油化工等行业。

经过二十多年的发展壮大，公司管理水平及产品质量上了一个新的台阶，在行业中享有较高的声誉。我公司生产的产品品种齐全、牌号丰富、性能优异、质量稳定可靠，能够满足客户不同的需求，在国内占有重要的市场份额，并远销欧美、东南亚等国家和地区。

我公司拥有先进的生产设备，一流的检测中心，精密的模具生产线及深加工线。公司有优秀的研发团队，一直致力于高性能产品的研发及应用推广，并卓有成效。公司专业的销售工程师能够及时为广大客户推荐和提供最合适的产品及解决方案。

公司真诚感谢新老客户多年来对精工的信任和支持，并郑重承诺把产品质量和服务做得更好。

我们坚信，与株洲精工的合作，一定是您最理想的选择。

Zhuzhou Jinggong Cemented Carbide Co., Ltd is located at Zhuzhou National Hi-Tech Development Zone. The company is one high-tech joint-stock enterprise integrating the research and development, production and sales of cemented carbide products. The main products are cutting tools, saw tips, mining tools, die materials, carbide rods and non-standard carbide products. They are widely used in the mold industry, automobile industry, rail transit, construction machinery, 3C industry, aerospace, energy equipment, general machinery, petrochemical industry and other industries.

The company, after more than two decades of development and expansion, has made a great leap forward in the management level and product quality, enjoying a rather high reputation in the carbide industry. The company-made carbide products have a full range of varieties, featured by rich grades and stable performance. The products can meet the different needs of customers, and occupy an important market share in China and export to Europe, United States, Southeast Asia and other countries and regions.

The company has advanced production equipment, first-class testing center, precision mold production lines and deep processing lines. The R & D team have always been committed to research, development and application of high-performance cemented carbide products, and have achieved remarkable results. Our professional sales engineers can recommend and provide the most suitable products and solutions for our customers in a timely manner.

We sincerely express our thanks to our new and old customers for your trust and support over the years, and solemnly promise to do better in product quality and service.

We believe, the cooperation with Zhuzhou Jinggong Company must be your optimal choice.

资质荣誉

QUALIFICATION HONOR

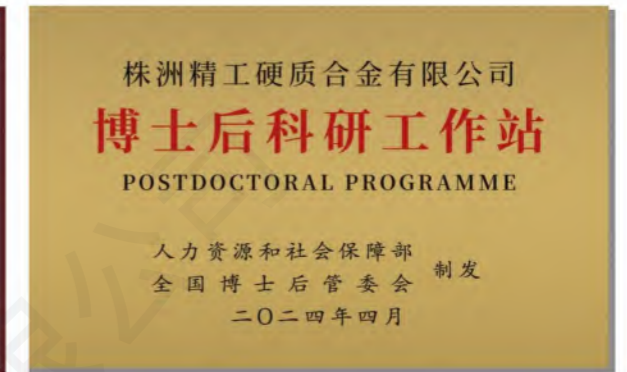

www.jgcarbide.com



车削刀具 Turning Tools

车削刀片牌号一览表 Grades Table for Turning Inserts	07
车削刀片牌号介绍 Grade Introduce of Turning Inserts	09
普通车削刀片型号命名规则 Naming Rules of Turning Inserts	17
普通车削刀片 General Turning Inserts	19
镗孔精车刀片 Boring Inserts for precision turning	39
加工案例 Application Cases	41
普通车削加工切削推荐表 Table of Recommended Cutting Parameters for General Turning	45
螺纹刀片型号命名规则 Naming Rules of Threading Turning Inserts	48
螺纹车削刀片 Threading Turning Inserts	50
螺纹加工切削用量推荐表 Table of Recommended Cutting Parameters for Threading	52
切断切槽刀片型号命名规则 Naming Rule of Parting and Grooving Inserts	54
切断切槽车削刀片 Parting and Grooving Inserts	56
切断切槽车削加工案例 Application Cases of Parting and Grooving Inserts	57
切断切槽刀具切削用量推荐表 Table of Recommended Cutting Parameters for Parting and Grooving	58
车削加工常见问题及解决方案 Common Problems and Solutions In Turning	59

外圆车刀杆命名规则 Naming Rules of External Turning Tool holders	62
外圆车刀杆系列 Series of External Turning Tool Holders	63
内孔车刀杆命名规则 Naming Rules of Internal Turning Tool Holders	70
内孔车刀杆系列 Series of Internal Turning Tool Holders	71

铣削刀具 Milling Tools

铣削刀片牌号一览表 Grades Table for Milling Inserts	77
普通铣削刀片型号命名规则 Naming Rules of Milling Inserts	79
普通铣削刀片 General Milling Inserts	81
铣削刀片加工案例 Application Cases for Milling	99
铣削加工常见问题及解决方案 Common Problems and Solutions In Milling	101

孔加工刀具 Hole Machining Tools

浅孔钻刀片 Shallow hole drilling Inserts	105
深孔钻刀片 Deep-hole drilling Inserts	107



目录 CONTENTS

整硬刀具 Solid Carbide Cutting Tools

铣刀命名规则 Naming Rules for Solid Milling Tools	114
整体硬质合金铣刀系列 Solid Carbide Milling Tool Series	115
立铣刀常见问题及对策 Common Problems and Solutions for End Mill	128

通用信息技术 General Technical Information

刀具规格选用办法 Selection Method of Cutting Tools	131
牌号对照表 Grade Comparison Table	133
硬度对照表 Hardness Comparison Table	135
安全使用注意事项 Precautions for Safe Use of Cutting Tools	136
硬质合金产品安全标准 Safety Standard for Cemented Carbide Products	137



P20

P21

P23

P33

P30

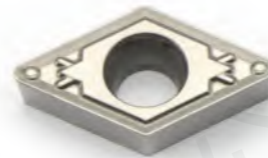

P31

P40



P36

P26



车削

Turning Tools



车削刀片牌号一览表	07
Grades Table for Turning Inserts	
车削刀片牌号介绍	09
Grade Introduce of Turning Inserts	
普通车削刀片型号命名规则	17
Naming Rules of Turning Inserts	
普通车削刀片	19
General Turning Inserts	
镗孔精车刀片	39
Boring Inserts for precision turning	
加工案例	41
Application Cases	
普通车削加工切削推荐表	45
Table of Recommended Cutting Parameters for General Turning	
螺纹刀片型号命名规则	48
Naming Rules of Threading Turning Inserts	
螺纹车削刀片	50
Threading Turning Inserts	
螺纹加工切削用量推荐表	52
Table of Recommended Cutting Parameters for Threading	
切断切槽刀片型号命名规则	54
Naming Rule of Parting and Grooving Inserts	
切断切槽车削刀片	56
Parting and Grooving Inserts	
切断切槽车削加工案例	57
Application Cases of Parting and Grooving Inserts	
切断切槽刀具切削用量推荐表	58
Table of Recommended Cutting Parameters for Parting and Grooving	
车削加工常见问题及解决方案	59
Common Problems and Solutions In Turning	
外圆车刀杆命名规则	62
Naming Rules of External Turning Tool holders	
外圆车刀杆系列	63
Series of External Turning Tool Holders	
内孔车刀杆命名规则	70
Naming Rules of Internal Turning Tool Holders	
内孔车刀杆系列	71
Series of Internal Turning Tool Holders	

车削刀片牌号一览表 Grades Table for Turning Inserts

ISO使用 ISO Use	ISO代号 ISO Code	普通车削 Turning				螺纹 Threading	切断切槽 Parting and Grooving	
		涂层 Coating		金属陶瓷 Cermets	硬质合金 Cemented carbide	涂层 Coating		
		CVD	PVD			PVD	PVD	CVD
P 钢件 Steel	P01		JGA05A					
	P10	JGP15T	JGA10E			JGA20F		
	P20	JGP15S JGP25T JGP25S JGP40T JGP40S	JGA20F JGA20H JGA30F	JTN20		JGA20F	JGP15T JGP25T	
	P30			JTN35				
	P40							
M 不锈钢 Stainless Steel	M01							
	M10		JGA10A			JGA20F		
	M20	JGM20R	JGA20F JGA30A JGA30F			JGA20F		
	M30							
	M40							
K 铸铁 Cast Iron	K01					JGA20F		
	K10	JGK10R						
	K20	JGK20R					JGA20F	JGP25TA
	K30							
N 有色金属 Non-Ferrous Metal	N01							
	N10			JS10A JS20A				
	N20							
	N30							
S 钛合金 耐热合金 Titanium Alloy Heat-Resisting Alloy	S01							
	S10	JGM20R						
	S20	JGM30R	JGS20A JGS20C					
	S30							
H 高硬度 材料 High Hardness Material	H01							
	H10		JGA05A JGA05F					
	H20							
	H30							



A
车削刀片
Turning Inserts

A
车削刀片
Turning Inserts



JGA05A

高硬度的超微粒硬质合金基材与韧性和耐磨性都很好的特殊纳米涂层相结合，可提供具有锋利的切削刃和机械冲击性，是不锈钢的要求小公差和高表面质量的精加工牌号。

High hardness superfine grain cemented carbide substrate, combined with special nano-coating with excellent toughness and wear resistance, It can provide sharp cutting edge and mechanical impact. Fine finishing grade for stainless steel cutting which requires small tolerance and high surface quality.

JGA05F

高硬度的超微粒硬质合金基材与韧性和耐磨性都极好的特殊纳米NEO PLUS涂层技术相结合，积层的间隔更薄，积层数的增加可抑制崩损等异常损伤，可同时实现长寿加工和优异的精加工面。适用不锈钢、耐热合金超精加工。

High hardness superfine grain cemented carbide substrate, combined with nano NEO PLUS coating with excellent toughness and wear resistance. It can make the interval of lamination thinner, and the increase of lamination can inhibit the abnormal damage such as breakage, so as to achieve long life machining and excellent finishing surface at the same time. Superfine finishing grade for cutting stainless steel and heat-resisting alloy.

高硬合金基体

High Hardness Substrate

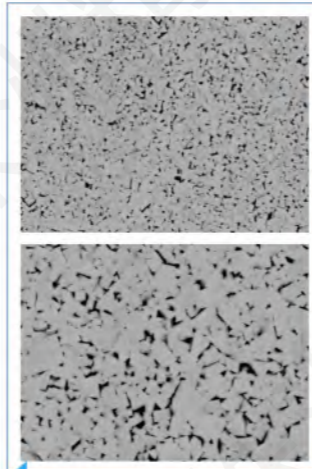

基体介绍 Substrate Introduction

细晶WC和低Co含量设计，添加少量的复合晶粒长大抑制剂，材质具有很高的硬度。

Fine grain WC and low Cobalt content design, A small amount of grain growth inhibitor is added. The material has a super high hardness.

自主研发

Independent R&D

含Si涂层牌号

Si-Containing coating

JGA10A



微细颗粒搭配自己研发含Si涂层，使得刀片具有更高耐磨性和抗氧化性。应用于硬料、不锈钢加工，高速加工有着优秀的寿命表现和稳定性。

The combination of fine particles and our designed Si-Containing Coating, can make the inserts with higher wear resistance and oxidation resistance. It is used for machining hard material and stainless steel. It has excellent life performance and stability during high speed processing.

基体介绍 Substrate Introduction

细晶WC和中Co含量设计，添加少量的晶粒长大抑制剂。高韧性和较高硬度的完美结合。

Fine grain WC and medium Cobalt content design, A small amount of grain growth inhibitor is added. The perfect combination of high toughness and high hardness.

应用领域 Application Field

应用于钢件材料加工，汽车、模具行业加工。

Used in steel material processing, automobile, mold industry processing.

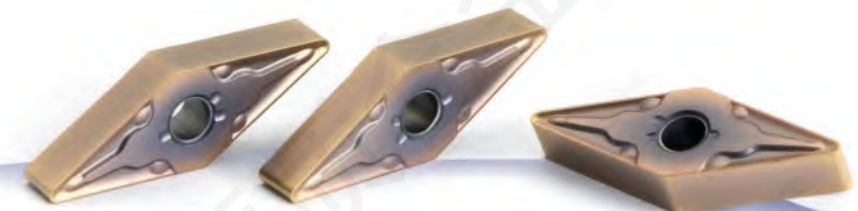
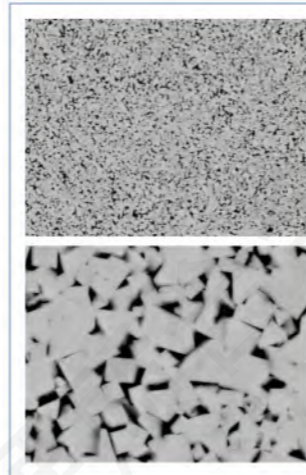

不锈钢车削加工技术新牌号

New grades for stainless steel turning

CVD 涂层硬质合金

CVD Coated Cemented Carbide



JGM20R

CVD涂层牌号专门用于对奥氏体不锈钢材料进行中速、高速切削的精加工至一般加工。与特有槽型的结合可以避免切深处的破损，并且减少毛口的形成，减少微崩刃和积屑瘤的形成，并提高工作的精加工质量。

Grade with CVD coating, specially used for medium speed and high speed cutting of austenitic stainless steel from fine finishing to rough processing. The combination with special chip-breakers can avoid the breakage of cutting depth, reduce the formation of burrs, the micro avalanche edge and built-up edges, and improve the finishing quality of the work.



基体介绍 Substrate Introduction

中颗粒WC硬质相与粘结相Co的经典结合；具有优异的韧性和适中的硬度。

Classic combination of medium particle WC hard phase and Co bonded phase. With excellent toughness and moderate hardness.

应用领域 Application Field

用于加工条件极为苛刻的铸造不锈钢材料加工。基体可用于重型断续切削，涂层具有耐磨性，可以延长刀具寿命。

Used for machining cast stainless steel materials under very harsh processing conditions. The substrate can be used for heavy intermittent cutting, the coating has good wear resistance and can prolong tool life.

JGM30R

CVD复合涂层牌号，基体为一种韧性极强的材料，用于加工条件极为苛刻的铸造不锈钢材料加工。基体可用于重型断续切削，涂层具有耐磨性，可以延长刀具寿命。经过抛光处理的表面可以避免积屑瘤的形成，可以进行大进给大切削的加工。

Grade with CVD coating, the substrate is a very tough material, used for machining cast stainless steel materials under very harsh processing conditions. The substrate can be used for heavy-duty intermittent cutting, and the coating has good wear resistance and can prolong tool life. The polished surface can avoid the formation of built-up edges and can be machined with big feed cutting.

NEW

钢件加工

Grades for Steel turning

JGP25T

一种新型，具有很强的抗变形能力的富钴含量基材，专门设计的CVD复合涂层，用于对多种钢材料，铁素体，马氏体，PH不锈钢进行粗加工至半精加工的应用范围。具有卓越的抗变形性能以及出色的刀片刃口强度，采用先进的涂层去应力处理工艺的新型涂层，具有出色的加工效率，超长并可以预测的刀具寿命，以及卓越的工作表面加工质量。

A new specially designed CVD composite coating with strong deformation resistance and rich cobalt content base material. Suitable for finishing to semi-finishing of various steel materials, ferrite, martensitic, PH stainless steel. With excellent deformation resistance and blade edge strength. A new coating with advanced coating stress removal process has excellent processing efficiency, predictable long tool life and excellent working surface processing quality.

JGP25S

一种特别设计的高钴硬质合金材质，以及具有出色的抗磨损性能的复合CVD厚涂层，用于多种工件材料，包括钢材料，铁素体、马氏体，钴基材料基体在抗变形性能和刀刃韧性之前有着良好的平衡性，厚涂层在高速切削中具有出色的耐磨性和抗月牙洼磨损性。光滑的涂层表面可以避免积屑和微崩刃现象，在苛刻的断续切削也具有很高的金属切除率。

A specially designed high cobalt cemented carbide material. A composite CVD thick coating with excellent wear resistance, used for processing a variety of workpiece materials, which includes steel material, ferrite, martensite. Cobalt-based material matrix has a good balance before deformation resistance and blade toughness. Thick coating has excellent wear resistance and crescent wear resistance in high speed cutting. Smooth coating surface can avoid chip accumulation and micro avalanche edge. It has high metal removal rates in harsh intermittent cutting.



CVD 复合涂层 Composite coating

基体介绍 Substrate Introduction

耐高温组元设计；刀片具有良好的红硬性和抗塑性变形能力；专业化制备工艺使得基体韧性得以大幅度提升。

High temperature resistant component design; The blade has good red hardness and resistance to plastic deformation; The specialized substrate process can greatly improve the toughness of the matrix.

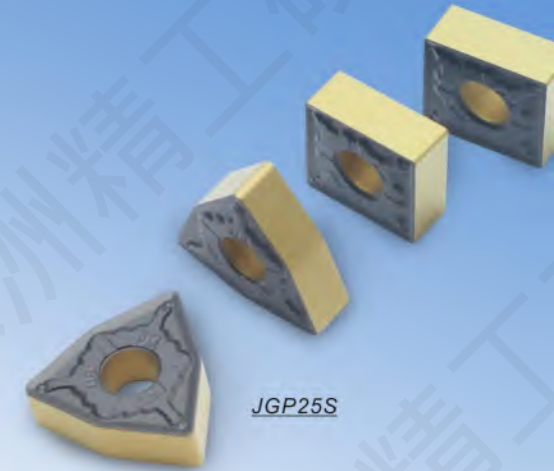

JGP25S



JGP25T



JGP25S

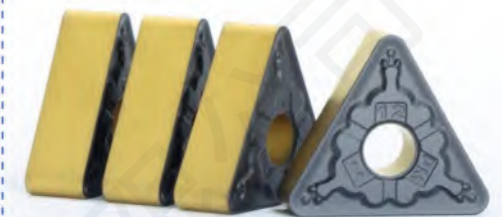

铸铁加工

Grade for cast iron turning



铸铁高效加工的首选

The first choice for efficient processing of cast iron

▶ JGK10R

硬的基体有很高的高温硬度，因此有良好的抗塑性变形性，用于灰铸铁和球墨铸铁材料的高速切削加工，具有很好的切削性能。这种基体允许刀片进行长时间的高速切削，刀片变形量很小，CVD厚涂层以及涂层去应力处理工艺使刀片具有卓越的耐磨性，确保刀具具有超长的使用寿命，是铸铁类高速切削的理想选择。

The hard substrate has very good high temperature hardness, so it has good plastic deformation resistance. It is used for high speed cutting of gray cast iron and nodular iron materials, and has consistent cutting performance. CVD with thick coating and stress removal process can make the inserts with excellent wear resistance and ensure the tool has long service life. It is an ideal choice for high speed cutting of cast iron.

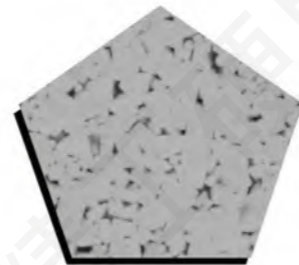

基体介绍 Substrate Introduction

▶ JGK20R

一种经过特别增加韧性处理的MT-CVD, TiCN-Al₂O₃涂层，基体具有很好的耐磨性，增加了涂层的附着性以及刀刃的强度，对灰铸铁和球墨铸铁材料进行湿式断续切削的理想材质。这种材质的应用范围广泛，从精加工到粗加工，在对高强度和加工可靠性有较高要求的加工中具有非常出色的加工效率。

MT-CVD, TiCN-Al₂O₃ coating treated with special increased toughness. The substrate has good wear resistance, increases the adhesion of the coating and the strength of the insert, and is an ideal material for wet interrupted cutting of gray cast iron and nodular iron materials. This material has a wide range of applications from fine finishing to rough processing, and has an excellent processing efficiency in the process which requires high strength and processing reliability.



基体介绍 Substrate Introduction

金属陶瓷 CERMET

▶ JTN20

金属陶瓷牌号，对金属陶瓷粘合剂（镍、钴）与特殊高熔点粘合剂进行特殊的强化混合技术，兼具优秀的抗崩损性与耐磨损性能，广泛覆盖钢的精加工到粗加工领域。

Cermet grade, with the special mixing enhancement technology for cermet adhesive (nickel, cobalt) and special high melting point adhesive, it has excellent edge wear resistance, widely used in the field of steel cutting from fine finishing to rough processing.

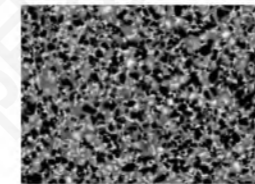

基体介绍 Substrate Introduction



应用领域 Application Field

▶ JTN35

INNOVA系列金属陶瓷牌号，对金属陶瓷粘合剂（镍、钴）与特殊高熔点粘合剂进行特殊的强化混合技术，有效抑制切削时粘合剂的软化，具有良好的抗塑性变形性，此牌号没有涂层，保证了在整个刀具寿命期间都有锋利的切削刃，这意味着良好的表面质量和低切削力，这是在高速和低速条件下能保证高表面质量的精加工牌号。

INNOVA series of cermet grades. with the special mixing enhancement technology of cermet adhesive (nickel, cobalt) and special high melting point adhesive, it is used to effectively inhibit the softening of adhesive during cutting, and has good plastic deformation resistance. This grade has no coating and ensures sharp cutting edges throughout the tool life, which means good surface quality and low cutting force. This is the fine finishing grade which can guarantee high surface quality under high speed and low speed conditions.

通用加工牌号 推荐

General processing grade **re**commendation

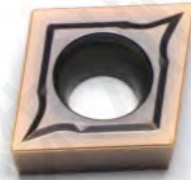
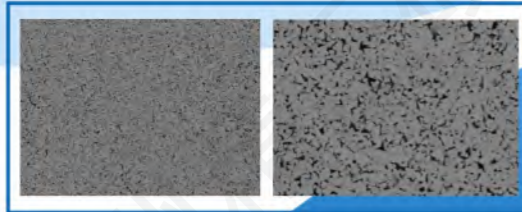

JGA30A

高强韧性的耐磨基材结合耐磨性良好的含Si涂层。使刀片在保持良好耐磨性的同时具有极强的抗冲击韧性。适合于复杂工况下的硬料、不锈钢等难加工材料的加工。

High toughness and wear-resistant substrate, in combination with Si-containing coating can keep the carbide inserts in strong impact toughness and good wear resistance. It is suitable for processing hard materials, stainless steel and other materials which are difficult to be processed, under complex working conditions.

JGA30F

极高韧性的基体材料配合自主研发的纳米复合涂层，在各种恶劣工况下表现出良好的抗刃口崩缺、抗磨损性能，是通用铣削加工的首选牌号。

The matrix materials which are of high toughness and combined with self-developed nano composite coating can keep the carbide inserts in good wear resistance and cutting edge breakage resistance under various harsh working conditions. It is the preferred grade for general milling.

▼ S 类

难加工材料牌号

Grades for **class S** materials turning



JGS20C

采用自主研发的抗高温性能优异的特殊合金基体。配合韧性强，耐磨性能优异的涂层材料。适用于钛合金等难加工航天航空材料的加工。

By adopting special alloy substrate which are of excellent high temperature resistance developed by ourselves, the coating materials have strong toughness and excellent wear resistance. It is suitable for processing difficult aerospace materials such as titanium alloy.

JGS20A

采用先进的功能梯度复合材料技术，制备出了在高温及强负荷下具备超强的抗蠕变、抗氧化的基体合金材料。配合纳米复合涂层技术，通过高耐磨损元素的固溶强化，强化了涂层在高温下的耐磨及抗氧化性能。特别适用于镍基高温合金、钴基高温合金等极难加工材料的加工。

By adopting advanced functionally graded composite technology, the substrate materials which are of super creep resistance and oxidation resistance under high temperature and strong load are prepared. In combination with nano composite coating technology, the wear resistance and oxidation resistance of the coating at high temperature were enhanced by solid solution strengthening of high wear resistance elements. It is especially suitable for processing materials that are extremely difficult to be processed, such as nickel-based super alloys and cobalt-based super alloys.

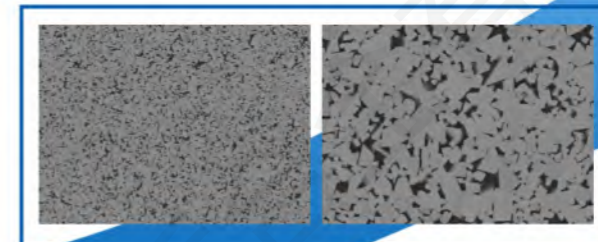

普通车削刀片型号命名规则 Naming Rules of Turning Inserts

刀片形状/代号 Shape of insert/code				
A	B	C	D	E
H	K	L	M	O
P	R	S	T	T
V	W	Z	其他 Others	

形状代号
Code of insert shape

公制 Metric system							
代号 Code	有无孔 With/Without hole	有无断屑槽 With/Without chipbreaker	刀片剖面 Section plane of insert	代号 Code	有无孔 With/Without hole	有无断屑槽 With/Without chipbreaker	刀片剖面 Section plane of insert
B	有 With	无 Without		N	无 Without	无 Without	
H	有 With	单面 Single-side		R	无 Without	单面 Single-side	
C	有 With	无 Without		F	无 Without	双面 Double-side	
J	有 With	双面 Double-side		A	有 With	无 Without	
W	有 With	无 Without		M	有 With	单面 Single-side	
T	有 With	单面 Single-side		G	有 With	双面 Double-side	
Q	有 With	无 Without		X	—	—	特殊 Special
U	有 With	双面 Double-side					

断屑槽及夹固形式
Chip-breaking groove and clamping form

内切圆直径 (mm) Diameter or IC	刀片形状 Shape of inserts						
	C	D	R	S	T	V	W
3.97					06		
5.0				05			
5.56					09		
6.0				06			
6.35	06	07			11	11	
8.0				08			
9.525	09	11	09	09	16	16	06
10.0				12			
12.0				12			
12.7	12	15	12	12	22	22	08
15.875	16	15	15	15	27		
16.0		19	16				
19.05	19	19	19	19	33		
20.0				20			
25.0	25	25	25	25			
25.4				25			
31.75				31			
32				32			

切削刃长度
Length of cutting edge

断屑槽型代号 Chip-breaker Code	
SM3	精加工 Finishing
PM4	半精加工 Semi-finishing
PF3	精加工 Finishing
HS2	精加工 Finishing
KN5	半精加工 Semi-finishing

C N M G

12 04 08 - SM3

主切削刃后角 Clearance angle of main cutting edge			
代号 Code	后角(度) Clearance angle	代号 Code	后角(度) Clearance angle
A	3°	B	5°
C	7°	D	15°
E	20°	F	25°
G	30°	N	0°
P	11°	O	其他后角 Other Clearance angle

公差 Tolerance										
代号 Code	刀尖高度m 公差 (mm) Nose height m Tolerance(mm)	内切圆φI.C 公差(MM) Inscribed circle φI.C Tolerance(mm)	厚度S, 公差 (mm) Thickness S Tolerance(mm)	(参考)M级精度详细情况 (按形状、大小分) (Reference)Details of M-level tolerance(Identified by shape)						
				● 刀尖高度公差 Nose height tolerance (mm)						
				内切圆 Inscribed circle	正三角形 Regular triangle	正方形 Square	80°菱形 Diamond with 80°	55°菱形 Diamond with 55°	35°菱形 Diamond with 35°	圆形 Round
A	±0.005	±0.025	±0.025	6.35	±0.08	±0.08	±0.08	±0.11	±0.16	—
F	±0.005	±0.013	±0.025	9.525	±0.08	±0.08	±0.08	±0.11	±0.16	—
C	±0.013	±0.025	±0.025	12.7	±0.13	±0.13	±0.13	±0.15	—	—
H	±0.013	±0.013	±0.025	15.875	±0.15	±0.15	±0.15	±0.18	—	—
E	±0.025	±0.025	±0.025	19.05	±0.15	±0.15	±0.15	±0.18	—	—
G	±0.025	±0.025	±0.13	25.4	—	±0.18	—	—	—	—
J	±0.005	±0.05-±0.13	±0.025	● 内切圆φI.C公差 Tolerance of inscribed circle φI.C (mm)						
K	±0.013	±0.05-±0.13	±0.025	内切圆 Inscribed circle	正三角形 Regular triangle	正方形 Square	80°菱形 Diamond with 80°	55°菱形 Diamond with 55°	35°菱形 Diamond with 35°	圆形 Round
L	±0.025	±0.05-±0.13	±0.025	6.35	±0.05	±0.05	±0.05	±0.05	±0.05	—
M	±0.08-±0.18	±0.05-±0.13	±0.13	9.525	±0.05	±0.05	±0.05	±0.05	±0.05	±0.05
N	±0.08-±0.18	±0.05-±0.13	±0.025	12.7	±0.08	±0.08	±0.08	±0.08	—	±0.08
U	±0.08-±0.18	±0.08-±0.25	±0.13	15.875	±0.10	±0.10	±0.10	±0.10	—	±0.10
				19.05	±0.10	±0.10	±0.10	±0.10	—	±0.10
				25.4	—	±0.13	—	—	—	±0.13

厚度指刀片底面与切削刃最高部分之间的高度 Thickness is defined as the height from the bottom of insert to the highest part of cutting edge	
代号 Code	刀片厚度 Thickness (mm)
00	0.79
T0	0.99
01	1.59
T1	1.98
02	2.38
T2	2.58
03	3.18
T3	3.97
04	4.76
T4	4.96
05	5.56
T5	5.95
06	6.35
T6	6.75
07	7.94
09	9.52
T9	9.72
11	11.11
12	12.70

刀片厚度
Thickness of inserts

刀尖圆弧代号 Nose radius code	
代号 Code	刀尖圆弧半径 Nose radius(mm)
00	无圆角 No radius
02	0.2
04	0.4
08	0.8
12	1.2
16	1.6
20	2.0
24	2.4
32	3.2
X	其他 Others

刀片直径
尺寸Mo
(公制)
Diameter of insert (Metric)

圆形刀片
Round insert

普通车削刀片
General Turning Inserts

CNMA/CNMG

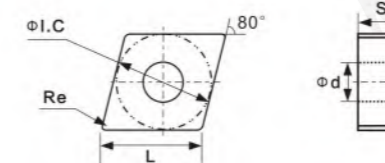
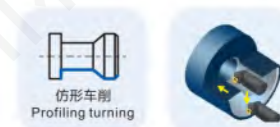

普通车削刀片
General Turning Inserts

刀片外形 Inserts Shape	型号 Type	基本尺寸 Dimension(mm)					牌号 Grade								
		phi I.C	L	S	phi d	Re	P		M	K	H	金陶 Cermet			
							JGP15S	JGP15T	JGP25S	JGP25T	JGA20F	JGA10A	JGM20R	JGK10R	JGA05A
	CNMA120404	12.70	12.90	4.76	5.16	0.4							●		
	CNMA120408	12.70	12.90	4.76	5.16	0.8							●		
	CNMA120412	12.70	12.90	4.76	5.16	1.2							●		
	CNMA160608	16.10	15.875	6.35	6.35	0.8							●		
	CNMG120408-KN5	12.70	12.90	4.76	5.16	0.8							●		
	CNMG120412-KN5	12.70	12.90	4.76	5.16	1.2							●		
	CNMG160608-KN5	16.10	15.875	6.35	6.35	0.8							●		
	CNMG120404-PM4	12.70	12.90	4.76	5.16	0.4	●	●	●	●					
	CNMG120408-PM4	12.70	12.90	4.76	5.16	0.8	●	●	●	●					
	CNMG120412-PM4	12.70	12.90	4.76	5.16	1.2	●	●	●	●					
	CNMG120404-SM3	12.70	12.90	4.76	5.16	0.4					●	●			
	CNMG120408-SM3	12.70	12.90	4.76	5.16	0.8					●	●			
	CNMG120412-SM3	12.70	12.90	4.76	5.16	1.2					●	●			
	CNMG120404-HS2	12.70	12.90	4.76	5.16	0.4								●	●
	CNMG120408-HS2	12.70	12.90	4.76	5.16	0.8								●	●
	CNMG120412-HS2	12.70	12.90	4.76	5.16	1.2								●	●
	CNMG120404-PM3	12.70	12.90	4.76	5.16	0.4					●	●			
	CNMG120408-PM3	12.70	12.90	4.76	5.16	0.8					●	●			
	CNMG120412-PM3	12.70	12.90	4.76	5.16	1.2					●	●			
	CNMG120408-PF4	12.70	12.90	4.76	5.16	0.8	●		●						

● 主推荐牌号 Main recommended grades ○ 一般牌号 General grades ○ 可生产牌号 Available grades

普通车削刀片
General Turning Inserts

VNMG/VNMG

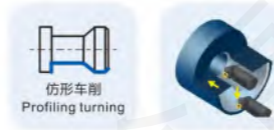
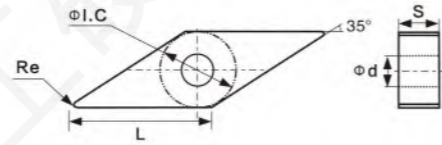

刀片外形 Inserts Shape	型号 Type	基本尺寸 Dimension(mm)					牌号 Grade													
		phi I.C	L	S	phi d	Re	P					M		K		H		金陶 Cermet		
							JGP15S	JGP15T	JGP25S	JGP25T	JGA20F	JGA10A	JGA30A	JGM20R	JGK10R	JGA05A	JTN20	JTN35		
	VNMG160404-PM4	9.525	16.60	4.76	3.81	0.4	●	●	●	●										
	VNMG160408-PM4	9.525	16.60	4.76	3.81	0.8	●	●	●	●										
	VNMG160412-PM4	9.525	16.60	4.76	3.81	1.2			●	●										
	VNMG160404-SM3	9.525	16.60	4.76	3.81	0.4					●	●								
	VNMG160408-SM3	9.525	16.60	4.76	3.81	0.8					●	●								
	VNMG160404-HS2	9.525	16.60	4.76	3.81	0.4												●	●	
	VNMG160408-HS2	9.525	16.60	4.76	3.81	0.8												●	●	
	VNMG160412-HS2	9.525	16.60	4.76	3.81	1.2												●	●	
	VNGG160404R-H	9.525	16.60	4.76	3.81	0.4												●	●	
	VNGG160404L-H	9.525	16.60	4.76	3.81	0.4												●	●	
	VNGG160404R-F	9.525	16.60	4.76	3.81	0.4												●	●	
	VNGG160404L-F	9.525	16.60	4.76	3.81	0.4													●	
	VNMG160408-KN5	9.525	16.60	4.76	3.81	0.8													●	
	VNMG160412-KN5	9.525	16.60	4.76	3.81	1.2													●	
	VNMG160408-SM4	9.525	16.60	4.76	3.81	0.8						●								

● 主推荐牌号 Main recommended grades ○ 一般牌号 General grades ○ 可生产牌号 Available grades

普通车削刀片
General Turning Inserts

WNMA/WNMG

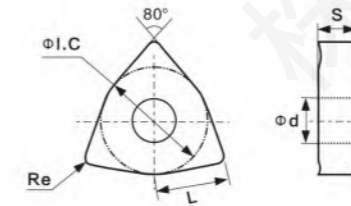

刀片外形 Inserts Shape	型号 Type	基本尺寸 Dimension(mm)					牌号 Grade														
		phi I.C	L	S	phi d	Re	P					M		K		H		金陶 Cermet			
							JGP15S	JGP15T	JGP25S	JGP25T	JGA20F	JGA10A	JGM20R	JGK10R	JGA05A	JTN20	JTN35				
	WNMA080404	12.70	8.70	4.76	5.16	0.4													●		
	WNMA080408	12.70	8.70	4.76	5.16	0.8													●		
	WNMA080412	12.70	8.70	4.76	5.16	1.2													●		
	WNMG080404-PM4	12.70	8.70	4.76	5.16	0.4	●	●	●	●											
	WNMG080408-PM4	12.70	8.70	4.76	5.16	0.8	●	●	●	●											
	WNMG080412-PM4	12.70	8.70	4.76	5.16	1.2	●	●	●	●											
	WNMG080404-SM3	12.70	8.70	4.76	5.16	0.4								●	●						
	WNMG080408-SM3	12.70	8.70	4.76	5.16	0.8								●	●						
	WNMG080412-SM3	12.70	8.70	4.76	5.16	1.2								●	●						
	WNMG080404-HS2	12.70	8.70	4.76	5.16	0.4														●	●
	WNMG080408-HS2	12.70	8.70	4.76	5.16	0.8														●	●
	WNMG080412-HS2	12.70	8.70	4.76	5.16	1.2														●	●
	WNMG080404-PM3	12.70	8.70	4.76	5.16	0.4									●	●					
	WNMG080408-PM3	12.70	8.70	4.76	5.16	0.8									●	●					
	WNMG080412-PM3	12.70	8.70	4.76	5.16	1.2									●	●					
	WNMG080408-KN5	12.70	8.70	4.76	5.16	0.8													●		
	WNMG080412-KN5	12.70	8.70	4.76	5.16	1.2													●		
	WNMG080408-SF3	12.70	8.70	4.76	5.16	0.8									●						

● 主推荐牌号 Main recommended grades ○ 一般牌号 General grades ○ 可生产牌号 Available grades

普通车削刀片
General Turning Inserts

DCMT

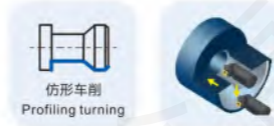
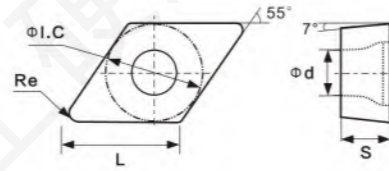

普通车削刀片
General Turning Inserts

SCMT

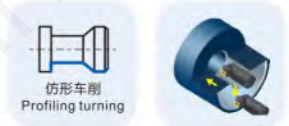
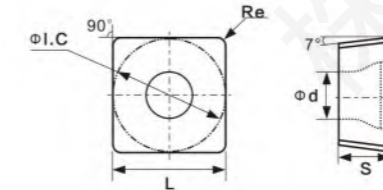

刀片外形 Inserts Shape	型号 Type	基本尺寸 Dimension(mm)					牌号 Grade										
		φI.C	L	S	φd	Re	P		M	K	H	金陶 Cermet					
							JGP15S	JGP15T	JGP25S	JGP25T	JGA20F	JGA10A	JGM20R	JGK10R	JGA05A	JTN20	JTN35
	DCMT070204-HS2	6.35	7.80	2.38	2.8	0.4										●	●
	DCMT070208-HS2	6.35	7.80	2.38	2.8	0.8										●	●
	DCMT11T304-HS2	9.525	11.60	3.97	4.4	0.4										●	●
	DCMT11T308-HS2	9.525	11.60	3.97	4.4	0.8										●	●
	DCMT070204-PF3	6.35	7.80	2.38	2.8	0.4										●	
	DCMT070208-PF3	6.35	7.80	2.38	2.8	0.8										●	
	DCMT11T304-PF3	9.525	11.60	3.97	4.4	0.4										●	
	DCMT11T308-PF3	9.525	11.60	3.97	4.4	0.8										●	
	DCMT070204-SM3	6.35	7.80	2.38	2.8	0.4					●	●					
	DCMT070208-SM3	6.35	7.80	2.38	2.8	0.8					●	●					
	DCMT11T304-SM3	9.525	11.60	3.97	4.4	0.4					●	●					
	DCMT11T308-SM3	9.525	11.60	3.97	4.4	0.8					●	●					
	DCMT11T304-PM4	9.525	11.60	3.97	4.4	0.4	●	●		●							
	DCMT11T308-PM4	9.525	11.60	3.97	4.4	0.8	●	●		●							

● 主推荐牌号 Main recommended grades ● 一般牌号 General grades ○ 可生产牌号 Available grades

刀片外形 Inserts Shape	型号 Type	基本尺寸 Dimension(mm)					牌号 Grade											
		φI.C	L	S	φd	Re	P		M	K	H	金陶 Cermet						
							JGP15S	JGP25S	JGP25T	JGP40S	JGA20F	JGA10A	JGM20R	JGK10R	JGA05A	JTN20	JTN35	
	SCMT09T304-HS2	9.525	9.525	3.97	4.4	0.4											●	●
	SCMT09T308-HS2	9.525	9.525	3.97	4.4	0.8											●	●
	SCMT120404-HS2	12.70	12.70	4.76	5.56	0.4											●	●
	SCMT120408-HS2	12.70	12.70	4.76	5.56	0.8											●	●
	SCMT09T304-SM3	9.525	9.525	3.97	4.4	0.4							●	●				
	SCMT09T308-SM3	9.525	9.525	3.97	4.4	0.8							●	●				
	SCMT120404-SM3	12.70	12.70	4.76	5.56	0.4							●	●				
	SCMT120408-SM3	12.70	12.70	4.76	5.56	0.8							●	●				
	SCMT09T304-PF3	9.525	9.525	3.97	4.4	0.4											●	
	SCMT09T308-PF3	9.525	9.525	3.97	4.4	0.8											●	
	SCMT120404-PF3	12.70	12.70	4.76	5.56	0.4											●	
	SCMT120408-PF3	12.70	12.70	4.76	5.56	0.8											●	

● 主推荐牌号 Main recommended grades ● 一般牌号 General grades ○ 可生产牌号 Available grades

普通车削刀片 General Turning Inserts

VBMT/VCMT

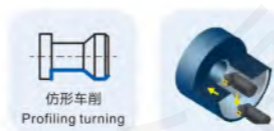
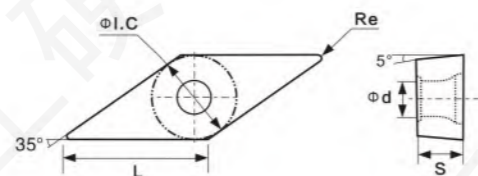

刀片外形 Inserts Shape	型号 Type	基本尺寸 Dimension(mm)					牌号 Grade											
		phi.I.C	L	S	phi.d	Re	P		M	K	H	金陶 Cermet						
							JGP15S	JGP25S	JGP25T	JGP40S	JGA20F	JGA10A	JGM20R	JGK10R	JGA05A	JTN20	JTN35	
	VBMT110304-HS2	6.35	11.00	3.18	2.8	0.4											●	●
	VBMT110308-HS2	6.35	11.00	3.18	2.8	0.8											●	●
	VBMT160404-HS2	9.525	16.50	4.76	4.4	0.4											●	●
	VBMT160408-HS2	9.525	16.50	4.76	4.4	0.8											●	●
	VBMT110304-SM3	6.35	11.00	3.18	2.8	0.4					●	●						
	VBMT110308-SM3	6.35	11.00	3.18	2.8	0.8					●	●						
	VBMT160404-SM3	9.525	16.50	4.76	4.4	0.4					●	●						
	VBMT160408-SM3	9.525	16.50	4.76	4.4	0.8					●	●						
	VBMT160404-MF3	9.525	16.50	4.76	4.4	0.4					●	●						
	VBMT160408-MF3	9.525	16.50	4.76	4.4	0.8					●	●						
	VCMT160404-SM3	9.525	16.50	4.76	4.4	0.4					●	●						
	VCMT160408-SM3	9.525	16.50	4.76	4.4	0.8					●	●						
	VBMT110304-PF3	6.35	11.00	3.18	2.8	0.4		●									●	
	VBMT110308-PF3	6.35	11.00	3.18	2.8	0.8		●									●	
	VBMT160404-PF3	9.525	16.50	4.76	4.4	0.4		●									●	
	VBMT160408-PF3	9.525	16.50	4.76	4.4	0.8		●									●	

● 主推荐牌号 Main recommended grades ● 一般牌号 General grades ○ 可生产牌号 Available grades

普通车削刀片 General Turning Inserts

KNUX

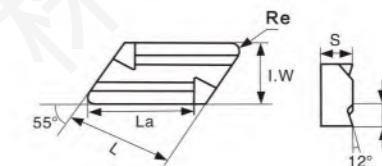

刀片外形 Inserts Shape	型号 Type	基本尺寸 Dimension(mm)						牌号 Grade										
		La	L	I.W	S	br	Re	P		M	K	H	金陶 Cermet					
								JGP15S	JGP25S	JGP25T	JGP40S	JGA20F	JGA10A	JGM20R	JGK10R	JGA05A	JTN20	JTN35
	KNUX160405-L11	17.2	16.15	9.25	4.76	2.7	0.5		●	●								
	KNUX160410-L11	17.2	16.15	9.25	4.76	2.7	1.0		●	●								
	KNUX160405-R11	17.2	16.15	9.25	4.76	2.7	0.5		●	●								
	KNUX160410-R11	17.2	16.15	9.25	4.76	2.7	1.0		●	●								

● 主推荐牌号 Main recommended grades ● 一般牌号 General grades ○ 可生产牌号 Available grades

普通车削刀片
General Turning Inserts

TNMX

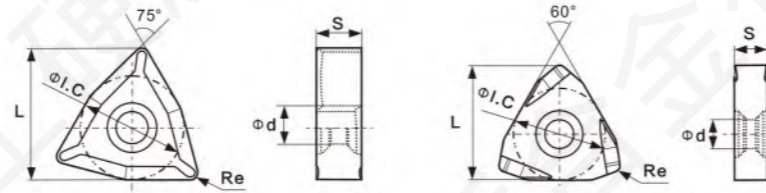

刀片外形 Inserts Shape	型号 Type	基本尺寸 Dimension(mm)					牌号 Grade											
							P		M	K	H	金陶 Cermet						
		phi.I.C	L	S	phi.d	Re	JGP15S	JGP25S	JGP25T	JGP40S	JGA20F	JGA10A	JGM20R	JGK10R	JGA05A	JTN20	JTN35	
	TNMX1509L-W	22.23	28.21	9.66	6.9	1.6	●											
	TNMX1507-HR8	22.10	27.64	8.01	7.0	1.6		●										

● 主推荐牌号 Main recommended grades ● 一般牌号 General grades ○ 可生产牌号 Available grades

普通车削刀片
General Turning Inserts

RNMG/RCMX

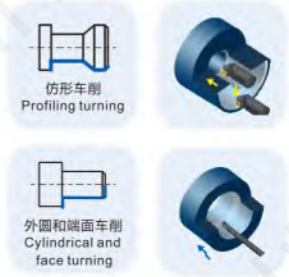
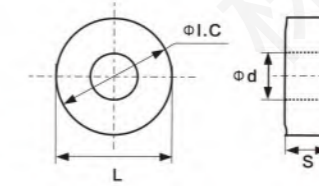

刀片外形 Inserts Shape	型号 Type	基本尺寸 Dimension(mm)				牌号 Grade											
						P		M	K	H	金陶 Cermet						
		phi.I.C	L	S	phi.d	JGP15S	JGP25S	JGP25T	JGP40S	JGA20F	JGA10A	JGM20R	JGK10R	JGA05A	JTN20	JTN35	
	RNMG120400	12.70	12.70	4.76	5.16		○	●									
	RCMX160600-PR8	16.00	16.00	6.35	5.50		○	●									
	RCMX200600-PR8	20.00	20.00	6.35	6.50		○	●									
	RCMX250700-PR8	25.00	25.00	7.94	7.18	●	○										
	RCMX320900-PR8	32.00	32.00	9.52	9.80	●	○										

● 主推荐牌号 Main recommended grades ● 一般牌号 General grades ○ 可生产牌号 Available grades

普通车削刀片 General Turning Inserts

CNMG/CNMM

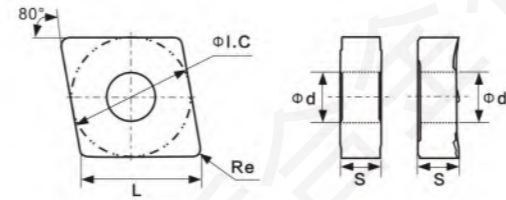

刀片外形 Inserts Shape	型号 Type	基本尺寸 Dimension(mm)					牌号 Grade															
		phi I.C	L	S	phi d	Re	P		M	K	H	金陶 Cermet										
							JGP15S	JGP25S	JGP25T	JGP40S	JGA20F	JGA10A	JGM20R	JGK10R	JGA05A	JTN20	JTN35					
	CNMG190612	19.05	19.34	6.35	7.94	1.2	●	○														
	CNMG160612-PR8	15.875	16.12	6.35	6.35	1.2	●	○														
	CNMG190608-PR8	19.05	19.34	6.35	7.94	0.8	●	○														
	CNMG190612-PR8	19.05	19.34	6.35	7.94	1.2	●	○														
	CNMG190616-PR8	19.05	19.34	6.35	7.94	1.6	●	○														
	CNMG250924-PR8	25.40	25.79	9.35	9.10	2.4	●	○														
	CNMM190612-PR8	19.05	19.34	6.35	7.94	1.2	●	○														
	CNMM190616-PR8	19.05	19.34	6.35	7.94	1.6	●	○														
	CNMM190624-PR8	19.05	19.34	6.35	7.94	2.4	●	○														
	CNMM250924-PR8	25.40	25.79	9.35	9.10	2.4	●	○	○													

● 主推荐牌号 Main recommended grades ○ 一般牌号 General grades ○ 可生产牌号 Available grades

普通车削刀片 General Turning Inserts

SNMA/SNMG/SNMM

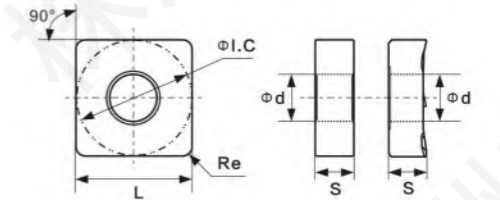

刀片外形 Inserts Shape	型号 Type	基本尺寸 Dimension(mm)					牌号 Grade															
		phi I.C	L	S	phi d	Re	P		M	K	H	金陶 Cermet										
							JGP15S	JGP25S	JGP25T	JGP40S	JGA20F	JGA10A	JGM20R	JGK10R	JGA05A	JTN20	JTN35					
	SNMA190612	19.05	19.05	6.35	7.94	1.2																
	SNMG190612	19.05	19.05	6.35	7.94	1.2	●	○														
	SNMG250924	25.40	25.40	9.525	9.12	2.4	●	○														
	SNMG190612-PR8	19.05	19.05	6.35	7.94	1.2	●	○														
	SNMG190624-PR8	19.05	19.05	6.35	7.94	2.4	●	○														
	SNMG250924-PR8	25.40	25.40	9.525	9.12	2.4	●	○														
	SNMM190612-PR8	19.05	19.05	6.35	7.94	1.2	●	○														
	SNMM190616-PR8	19.05	19.05	6.35	7.94	1.6	●	○														
	SNMM250924-PR8	25.40	25.40	9.525	9.12	2.4	●	○														

● 主推荐牌号 Main recommended grades ○ 一般牌号 General grades ○ 可生产牌号 Available grades

镗孔精车刀片

Boring Inserts for precision turning

T*GT/T*GH/TNMG

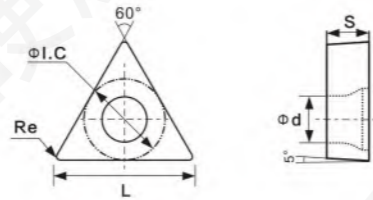

镗孔精车刀片

Boring Inserts for precision turning

TCMT

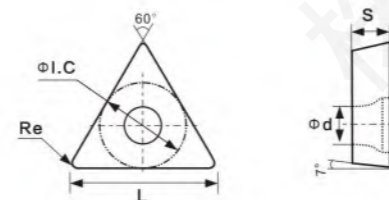

A 车削刀片 Turning Inserts

A 车削刀片 Turning Inserts

刀片外形 Inserts Shape	型号 Type	基本尺寸 Dimension(mm)					牌号 Grade																				
		φI.C	L	S	φd	Re	P					M K H 金陶 Cermet															
							JGP15S	JGP25S	JGP25T	JGP40S	JGA20F	JGA10A	JGM20R	JGK10R	JGA05A	JTN20	JTN35										
	TBGT060102L-W	3.97	6.876	1.59	2.2	0.2															●	●					
	TBGT060104L-W	3.97	6.876	1.59	2.2	0.4																●	●				
	TCGT110202L-W	6.35	11.0	2.38	2.8	0.2																●	●				
	TCGT110204L-W	6.35	11.0	2.38	2.8	0.4																	●	●			
	TPGT080202L-W	4.76	8.2	2.38	2.4	0.2																	●	●			
	TPGT080204L-W	4.76	8.2	2.38	2.4	0.4																		●	●		
	TPGT090202L-W	5.56	9.6	2.38	2.8	0.2																		●	●		
	TPGT090204L-W	5.56	9.6	2.38	2.8	0.4																			●	●	
	TPGT110302L-W	6.35	11.0	3.18	3.4	0.2																			●	●	
	TPGT110304L-W	6.35	11.0	3.18	3.4	0.4																				●	●
	TPGH080204L-FS	4.76	8.2	2.38	2.4	0.4																			●	●	
	TPGH090204L-FS	5.56	9.6	2.38	2.8	0.4																				●	●
	TPGH110304L-FS	6.35	11.0	3.18	3.4	0.4																				●	●
	TNMG160404R-2G	9.525	16.50	4.76	3.81	0.4																				●	●

● 主推荐牌号 Main recommended grades ● 一般牌号 General grades ○ 可生产牌号 Available grades

刀片外形 Inserts Shape	型号 Type	基本尺寸 Dimension(mm)					牌号 Grade																					
		φI.C	L	S	φd	Re	P					M K H 金陶 Cermet																
							JGP15S	JGP25S	JGP25T	JGP40S	JGA20F	JGA10A	JGM20R	JGK10R	JGA05A	JTN20	JTN35											
	TCMT090204-HS2	5.56	9.60	2.38	2.5	0.4																				●	●	
	TCMT090208-HS2	5.56	9.60	2.38	2.5	0.8																					●	●
	TCMT110204-HS2	6.35	11.00	2.38	2.8	0.4																					●	●
	TCMT110208-HS2	6.35	11.00	2.38	2.8	0.8																					●	●
	TCMT16T304-HS2	9.525	16.50	3.97	4.4	0.4																					●	●
	TCMT16T308-HS2	9.525	16.50	3.97	4.4	0.8																					●	●
	TCMT090204-SM3	5.56	9.60	2.38	2.5	0.4									●	●												
	TCMT090208-SM3	5.56	9.60	2.38	2.5	0.8									●	●												
	TCMT110204-SM3	6.35	11.00	2.38	2.8	0.4									●	●												
	TCMT110208-SM3	6.35	11.00	2.38	2.8	0.8									●	●												
	TCMT16T304-SM3	9.525	16.50	3.97	4.4	0.4									●	●												
	TCMT16T308-SM3	9.525	16.50	3.97	4.4	0.8									●	●												
	TCMT090204-PF3	5.56	9.60	2.38	2.5	0.4									●											○	●	
	TCMT090208-PF3	5.56	9.60	2.38	2.5	0.8									●											○	●	
	TCMT110204-PF3	6.35	11.00	2.38	2.8	0.4									●											○	●	
	TCMT110208-PF3	6.35	11.00	2.38	2.8	0.8									●											○	●	
	TCMT16T304-PF3	9.525	16.50	3.97	4.4	0.4									●											○	●	
	TCMT16T308-PF3	9.525	16.50	3.97	4.4	0.8									●											○	●	

● 主推荐牌号 Main recommended grades ● 一般牌号 General grades ○ 可生产牌号 Available grades

钢件车削

Turning Inserts for Steel

槽型特点

Characteristics of Chip-breakers

-PM4正刀片 PM4 Positive Inserts

碳钢、合金钢、软钢、不锈钢、铸铁中切削用断屑槽；
扁平棱边与大前角组合，确保刀刃强度与切削锋利性。

Chip-breaker for cutting carbon steel, alloy steel, soft steel, stainless steel and cast iron;
The combination of flat edge and large front angle can ensure edge strength and cutting sharpness.



-PM4负刀片 PM4 Negative Inserts

钢件半精加工首选槽型，能够实现高效、稳定的加工；
具备较宽排屑范围的通用断屑槽，通用性高；
靠近刀尖设计独特的形状凸起和大前角；
确保断屑槽保持切削性能的锋利和低切削力。

Preferred chip-breakers for semi-finishing machining of steel cutting, and can realize efficient and stable processing; Universal chip-breaker with wide chip-breaking effect and high versatility; Designed near the tip of the knife, with a distinctive shape bulge and large front angle. Ensure the chip-breakers maintaining sharp cutting performance and low cutting force.

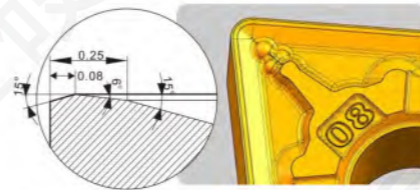

案例分析

Case Analysis

- 被加工材料 Processed material: 轮毂单元 /65Mn Hub Unit /65Mn
- 线速度 Linear velocity: $V_c=110\text{m/min}$
- 进给量 Feeding Rate: $f=0.23\text{mm/r}$
- 切削深度 Cutting Depth: $ap=1.0-1.5\text{mm}$

切削性能 Cutting Performance	
精工寿命 Life time of ZZJG inserts	92件/刃 Pieces/edge
国外某品牌 Life time of another brand	100件/刃 Pieces/edge

◆ -性价比优势高。
Cost-effective advantage.

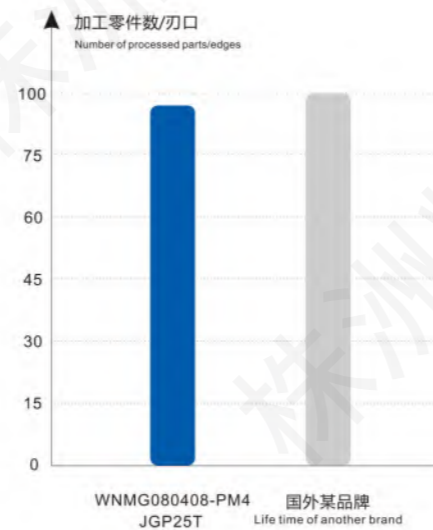

钢件车削

Turning Inserts for Steel

槽型特点

Characteristics of Chip-breakers

-PF3正刀片 PF3 Positive Inserts

用于精加工的断屑槽型，正前角精加工；
采用平行切削刃设计；
特殊的双前角三维槽型设计，切削力小，断屑范围宽；
大前角设计，与较深的断屑槽之间的高低差提升锋利度；
根据不同程度的切削深度对应凸起的断屑槽，
应用领域较为广泛。

Chip-breaker for precision processing with front angle finishing;
Design of parallel cutting edges;
Special design of 3D chip-breakers with double front angle, small cutting force and wide chip-breaking;
Large front angle design, and the deep chip chute between the height difference to enhance the edge sharpness;
According to different levels of cutting depth, there are corresponding raised chip-breakers. The application field is extensive.

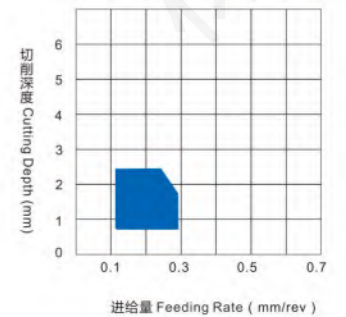

案例分析

Case Analysis

- 被加工材料 Processed material: 齿轮内孔/30Cr Gear bore / 30Cr
- 线速度 Linear velocity: $V_c=120\text{m/min}$
- 进给量 Feeding Rate: $f=0.18\text{mm/r}$
- 切削深度 Cutting Depth: $ap=2.0\text{mm}$

切削性能 Cutting Performance	
精工寿命 Life time of ZZJG inserts	60件/刃 Pieces/edge
国外某品牌 Life time of another brand	60件/刃 Pieces/edge

◆ -性能与竞争对手一致，我司产品加工出来的产品光洁度更好。
With the same performance as competitors, but the roughness of parts is better.

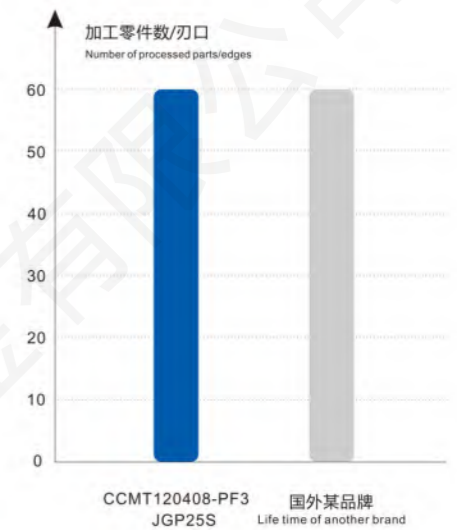

不锈钢车削

Turning Inserts for Stainless Steel

槽型特点

Characteristics of Chip-breakers

-SM3正刀片 SM3 Positive Inserts

中切削用断屑槽，采用大容屑槽。在大切削深度条件下也可降低切削阻力，减少高频颤动与切屑堵塞现象。

Medium Cutting Chip-breakers, Use Large chip-holding groove. Reduce cutting resistance even at large depth of cutting, Reduce high frequency vibration and cutting blocking.

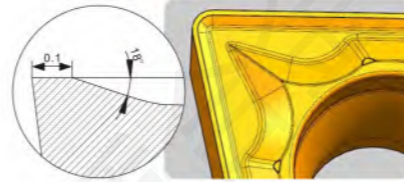

-SM3负刀片 SM3 Negative Inserts

不锈钢、软钢、难切削材料中切削；用优先推荐断屑槽，M级双面断屑槽；尖锐切削刃，切削锋利性高。通用性高的断屑槽形状。

Medium Cutting for Stainless Steel, Soft steel, hard cutting material; Use preferred recommended chip-breakers, M-class double-sided chip-breakers Sharp cutting edges, High cutting sharpness. Highly versatile chip-breaker shape.

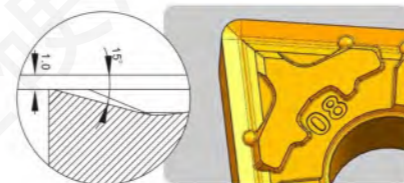

案例分析

Case Analysis

案例 A

- 被加工材料 40Cr (减速机轴类加工)
Processed material 40Cr (Reductor shaft processing)
- 工件直径 D=Φ35mm
Diameter of workpiece
- 转速 n=3800r/min
Rotating speed
- 进给量 f=0.06mm/r
Feeding Rate
- 切削深度 ap=0.8mm
Cutting Depth

切削性能 Cutting Performance	
精工寿命 Life time of ZZJG inserts	70件/刃 Pieces/edge
国外某品牌 Life time of another brand	50件/刃 Pieces/edge

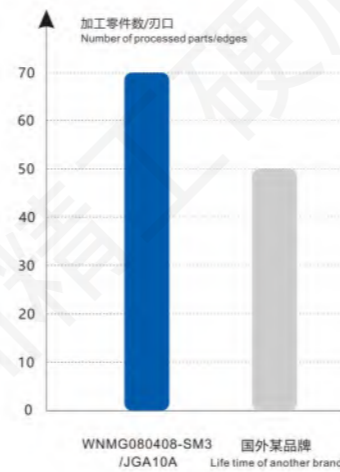

案例 B

- 被加工材料 304不锈钢
Processed material 304 stainless steel
- 工件直径 D = Φ40mm
Diameter of workpiece
- 转速 n=1500r/min
Rotating speed
- 进给量 f=0.08mm/r
Feeding Rate
- 切削深度 ap=0.6mm
Cutting Depth

切削性能 Cutting Performance	
精工寿命 Life time of ZZJG inserts	50件/刃 Pieces/edge
国外某品牌 Life time of another brand	60件/刃 Pieces/edge

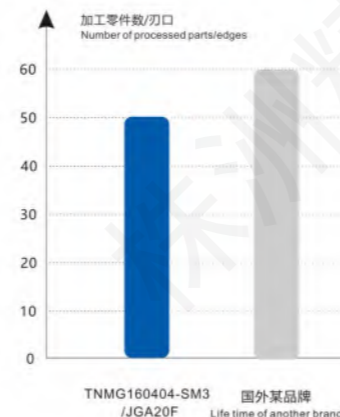

◆ -性价比优势高，具有较好的排屑效果。

High cost-effective advantage and good chip-breaking effect.

铸铁车削

Turning Inserts for Cast Iron

平面槽：脆性材料、高硬材料槽型，结构强度高，与刀杆贴合性强，更适合铸铁的不稳定车削。

Flat chip-breakers:

Chip-breaker for cutting brittle and hard material, with high structural strength and a good match to the tool holder. More suitable for unstable turning of cast iron.

通槽：通用加工槽型，双面断屑槽，尤其适合加工K类材料

Universal chip-breakers:

Universal chip-breaker type, double-sided chip-breakers, especially suitable for machining K-type materials.

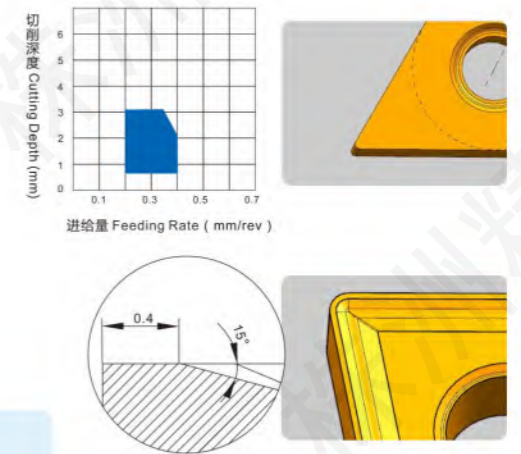

加工铸铁时的非正常失效与解决方案：

Unusual failures and solutions when processing cast iron:

非正常失效 Unusual failures	解决方案 Solutions
崩缺 Tipping 前刀面的倒棱处崩缺 Tipping at the chamfer on the front edge 精加工灰口铸铁时刃口崩缺 Tipping of the cutting edge during grey cast iron finishing	加大倒棱负前角。 Increase the negative front angle of the chamfer.
磨损 Wear 切削球墨铸铁时的磨损 Wear in cutting ductile iron 干式切削时的磨损 Wear during dry cutting 切削灰口铸铁时的磨损 Wear during grey cast iron cutting	改用干式切削。 Change to dry cutting. 降低切削线速度。 Reduce cutting line speed. 改用干式切削；提高切削线速度。 Change to dry cutting, increase line speed cutting.
表面质量 Surface quality 粗糙度差 Poor roughness 圆柱度、同轴度差 Poor cylindricity and coaxiality 毛刺 Burr	提高切削线速度；加大刀尖圆弧半径；降低进给量。 Increase cutting line speed; increase radius of the cutting edge; reduce the feeding rate. 减小刀尖圆弧半径；提高系统刚性；改用正角刀片。 Decrease radius of the tool tip arc; increase the rigidity of the system; change to positive-angle inserts. 改用正角刀片；减小倒棱宽度。 Change to positive-angle inserts; reduce chamfer width.

案例分析

Case Analysis

- 被加工材料 加工空调曲轴 / HT250材质
Processed material Crankshaft for processing air conditioning / HT250 Material
- 工件直径 D = 60mm
Diameter of workpiece
- 线速度 Vc=380m/min
Linear velocity
- 进给量 f=0.23mm/r
Feeding Rate
- 切削深度 ap=1.5mm
Cutting Depth

切削性能 Cutting Performance	
精工寿命 Life time of ZZJG inserts	135件/刃 Pieces/edge
国外某品牌 Life time of another brand	150件/刃 Pieces/edge

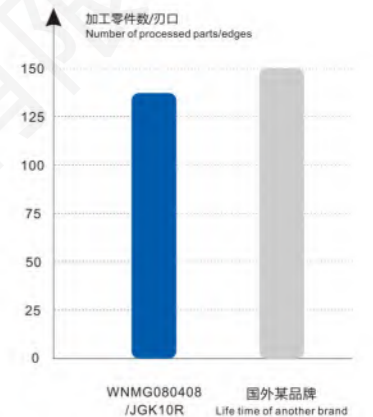

◆ -性能为国外某品牌的90%左右，性价比优势明显。

Performance is about 90% of another foreign brand, with obvious cost-effective advantage.

普通车削加工切削用量推荐表

Table of recommended cutting parameters for general turning

ISO	材料 Materials	硬度 HB Hardness HB	CVD涂层 CVD Coating					PVD涂层 PVD Coating					金属陶瓷 Cermet	涂层金属陶瓷 Coated Cermet	
			JGP10S	JGP15T	JGP15S	JGP20S	JGP25T	JGP25S	JGP40S	JGA10A	JGA20F	JGA20H	JTN20	JTN35F	
			进给量 Feed rate (mm/rev)												
			0.1-0.6 0.1-0.8 0.1-0.6 0.1-0.6 0.1-0.8 0.2-1.0 0.2-1.0 0.2-0.4 0.1-0.6 0.05-0.8										0.05-0.2 0.05-0.2		
切削速度 Cutting speed (m/min)															
P	碳素钢 Carbon steel	C=0.15%	125	500-270	430-190	430-200	500-270	480-240	380-165	430-220	460-220	380-180	360-165	550-350	580-350
		C=0.35%	150	460-250	380-180	410-180	460-250	460-230	300-150	350-200	440-210	300-170	280-150	500-300	520-300
		C=0.60%	200	400-220	330-150	350-150	400-220	400-200	260-130	310-180	380-180	260-150	240-130	460-260	480-260
	合金钢 Alloy steel	退火 Anneal	180	400-180	350-150	350-170	400-180	400-200	200-100	250-150	380-180	200-120	180-100	410-240	430-240
		淬硬 Hardened	275	280-150	210-100	230-200	280-150	260-140	140-70	200-120	240-120	140-90	120-70	300-180	320-180
		淬硬 Hardened	300	260-150	190-70	210-100	260-150	240-120	125-60	180-110	220-100	125-80	100-60	250-170	270-170
	高合金钢 High alloy steel	淬硬 Hardened	350	230-120	170-70	180-80	230-120	220-120	110-55	160-100	200-100	110-75	90-55	230-150	250-150
		退火 Anneal	200	360-190	260-120	320-150	360-190	310-170	175-80	220-130	290-150	175-100	155-80	350-200	370-200
	铸钢 Cast steel	非合金 Non-alloy	180	280-160	200-100	240-120	280-160	250-140	135-75	190-130	230-125	135-95	115-75	260-170	280-170
		低合金 Low-alloy	200	280-110	170-60	230-70	280-110	220-110	120-80	170-130	200-90	120-100	100-80	260-170	280-170
高合金 High-alloy		225	210-110	140-50	160-70	210-110	190-100	95-55	150-110	170-80	95-55	95-55	260-100	280-100	

ISO	材料 Materials	硬度 HB Hardness HB	CVD涂层 CVD Coating			PVD涂层 PVD Coating					
			JGM20R			JGA30A	JGA20F	JGA10A	JGA30F		
			进给量 Feed rate (mm/rev)								
			0.2-0.6						0.2-0.4 0.1-0.4 0.2-0.4 0.2-0.6		
切削速度 Cutting speed (m/min)											
M	不锈钢 Stainless steel	铁素体 Ferrite	180	280-180			290-190	300-190	290-190	250-150	
		奥氏体 Austenite	260	250-150			240-160	250-160	240-160	220-120	
		马氏体 Martensite	330	200-140			250-170	260-170	250-170	210-120	

普通车削加工切削用量推荐表

Table of recommended cutting parameters for general turning

ISO	材料 Materials	硬度 HB Hardness HB	CVD涂层 CVD Coating				金属陶瓷 Cermet	涂层金属陶瓷 Coated Cermet		
			JGK10R		JGK15R		JTN20	JTN35F		
			进给量 Feed rate (mm/rev)							
			0.1-0.4						0.1-0.4 0.1-0.4	
切削速度 Cutting speed (m/min)										
K	可锻 铸铁 Malleable cast iron	铁素体 Ferrite	130	350-230			330-220	280-160	300-180	
		珠光体 Pearlite	230	250-105			230-100	220-120	240-150	
	灰口铸铁 Gray cast iron		180	520-200			480-200	400-250	420-270	
			260	230-120			220-115	360-240	380-260	
	球墨 铸铁 Nodular cast iron	铁素体 Ferrite	160	310-150			300-150	330-190	350-210	
珠光体 Pearlite		250	230-110			220-105	310-200	330-220		

ISO	材料 Materials	硬度 HB Hardness HB	PVD涂层 PVD Coating			硬质合金 Cemented carbide			
			JGS20A	JGS20C	JGA05A	JS10A			
			进给量 Feed rate (mm/rev)						
			0.05-0.15 0.05-0.2 0.05-0.2					0.05-0.35	
切削速度 Cutting speed (m/min)									
N	铝合金 Al alloy	未热处理 No heat treatment	60				150-60		
		热处理 Heat treatment	100				150-60		
	铸铝 合金 Cast aluminum alloy	未热处理 No heat treatment	75				150-60		
		热处理 Heat treatment	90				150-60		
	铜合金 Copper alloy	铅合金 Lead alloy	110				150-60		
		铜、紫铜 Copper, pure copper	90				150-60		
S	镍基合金 Ni-base alloy	铜、无铅铜、电解铜 Copper, non-leaded Copper electrolytic copper	100				150-60		
		镍基合金 Ni-base alloy	40	100-60	100-60	100-60			
H	高硬材料 High hardness material	硬钢 Hard steel	45HRC			100-60			
		超硬钢 Extra-hard steel	50~60 HRC			100-60			
		冷硬铸铁 Chilled cast iron	500			100-60			



螺纹车削
Threading Inserts

螺纹刀片型号命名规则

Naming Rules of Threading Turning Inserts

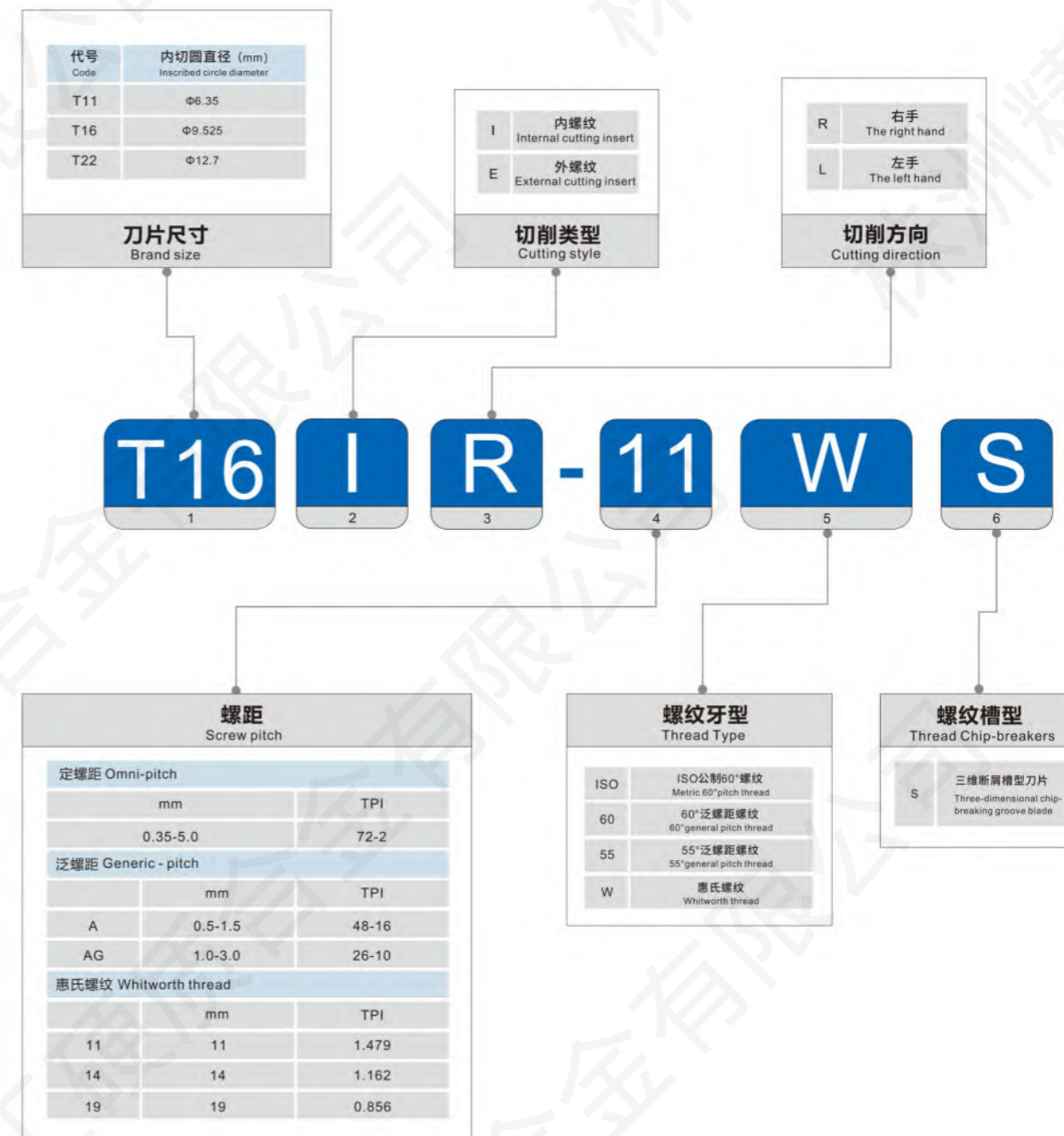

螺纹车削刀片 Threading Inserts

槽型特点

Characteristics of Chip-breakers

三维断屑槽型刀片

Three-dimensional chip-breaking groove blade

合理的槽型设计保证了加工中切削的有效排出；
加工表面光洁度高；
能实现钢、不锈钢，难切削材料等多种材质的螺纹加工。

Reasonable design of chip-breakers can ensure the effective discharge of cutting during machining;
With a high surface finish ;
It can realize thread processing of steel, stainless steel and hard cutting materials.

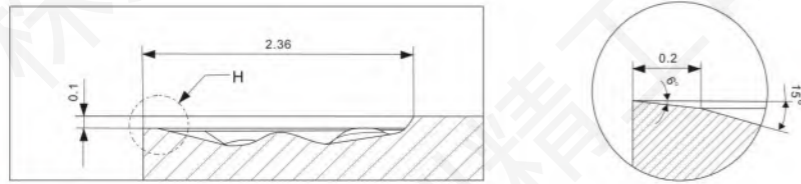

案例分析

Case Analysis

- ▶ 被加工材料 Processed material: 45#钢 45#steel
- ▶ 加工方式 Processing methods: 车削外圆加工 External Turning Processing
- ▶ 使用刀片 Use of inserts: T16IR1.5ISO/JGA20F
- ▶ 加工参数 Processing parameters: $V_c=128\text{m/min}$, $f=0.22\text{mm/r}$

在同等加工条件下，我司 T16IR 刀片切削轻快，断屑能力相当。性价比优势明显。

Under the same processing conditions, our T16IR cut easier and chip-breaking effect is good. Cost-effective advantage is obvious.

切削性能 Cutting Performance	
精工寿命 Life time of ZZJG inserts	160件/刃 Pieces/edge
国外某品牌 Life time of another brand	160件/刃 Pieces/edge

螺纹车削刀片 Threading Inserts

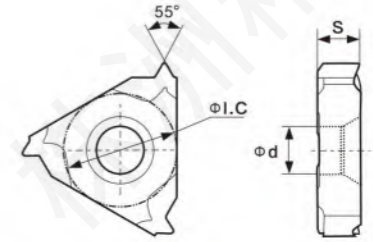

刀片外形 Inserts Shape	型号 Type	基本尺寸 Dimension(mm)				牌号 Grade												
		螺距 Pitch	φ1.C	S	φd	P					M	K	H	金陶 Cermet				
						JGP15S	JGP25S	JGP25T	JGP40S	JGA05F	JGA05E	JGM20R	JGK10R	JGA05A	JTN20	JTN35		
	T16IR-11WS	11	9.525	3.52	4.00						●	○						
	T16IR-14WS	14	9.525	3.52	4.00						●	○						
	T16ER-11WS	11	9.525	3.52	4.00						●	○						
	T16ER-14WS	14	9.525	3.52	4.00						●	○						

● 主推荐牌号 Main recommended grades ○ 一般牌号 General grades ○ 可生产牌号 Available grades

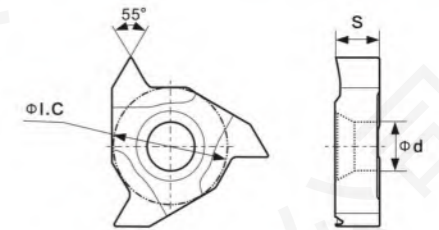

刀片外形 Inserts Shape	型号 Type	基本尺寸 Dimension(mm)				牌号 Grade												
		螺距 Pitch	φ1.C	S	φd	P					M	K	H	金陶 Cermet				
						JGP15S	JGP25S	JGP25T	JGP40S	JGA05F	JGA05E	JGM20R	JGK10R	JGA05A	JTN20	JTN35		
	T16ER-AG55S	0.5-3.0	9.525	3.52	4.00						●	○						
	T16ER-AG60S	0.5-3.0	9.525	3.52	4.00						●	○						

● 主推荐牌号 Main recommended grades ○ 一般牌号 General grades ○ 可生产牌号 Available grades

螺纹车削刀片 Threading Inserts

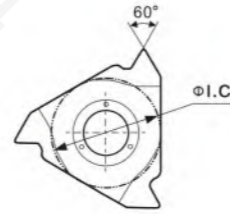

刀片外形 Inserts Shape	型号 Type	基本尺寸 Dimension(mm)				牌号 Grade															
		螺距 Pitch	φI.C	S	φd	P		M	K	H	金陶 Cermet										
						JGP15S	JGP25S	JGP25T	JGP40S	JGA05F	JGA05E	JGM20R	JGK10R	JGA05A	JTN20	JTN35					
	T16IR-1.0ISOS	1.0	9.525	3.52	4.00					●	○										
	T16IR-1.5ISOS	1.5	9.525	3.52	4.00					●	○										
	T16IR-2.0ISOS	2.0	9.525	3.52	4.00					●	○										
	T16IR-2.5ISOS	2.5	9.525	3.52	4.00					●	○										
	T16IR-3.0ISOS	3.0	9.525	3.52	4.00					●	○										
	T16ER-1.0ISOS	1.0	9.525	3.52	4.00					●	○										
	T16ER-1.5ISOS	1.5	9.525	3.52	4.00					●	○										
	T16ER-2.0ISOS	2.0	9.525	3.52	4.00					●	○										
	T16ER-2.5ISOS	2.5	9.525	3.52	4.00					●	○										
	T16ER-3.0ISOS	3.0	9.525	3.52	4.00					●	○										

● 主推荐牌号 Main recommended grades ○ 一般牌号 General grades ○ 可生产牌号 Available grades

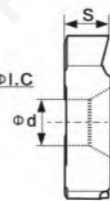
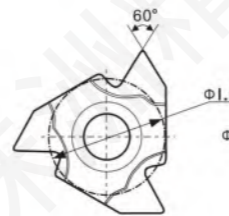

刀片外形 Inserts Shape	型号 Type	基本尺寸 Dimension(mm)				牌号 Grade															
		螺距 Pitch	φI.C	S	φd	P		M	K	H	金陶 Cermet										
						JGP15S	JGP25S	JGP25T	JGP40S	JGA05F	JGA05E	JGM20R	JGK10R	JGA05A	JTN20	JTN35					
	22IRN60-TC	3.5-5.0	12.70	4.71	5.00					●	○										

● 主推荐牌号 Main recommended grades ○ 一般牌号 General grades ○ 可生产牌号 Available grades

螺纹加工切削用量推荐表

Table of recommended cutting parameters for threading

ISO	材料 Materials	硬度HB HardnessHB	牌号 Grade		
			JGA05E	JGA05F	
			切削速度m/min Cutting speed m/min		
P	碳素钢 Carbon steel	C=0.15% C=0.35% C=0.60%	125-200	150-175 140-155 130-145	130-160 130-150 120-140
	合金钢 Alloy steel	退火 Anneal 淬硬 Hardened 淬硬 Hardened 淬硬 Hardened	180-350	110-130 80-100 70-90 60-80	100-120 70-90 60-80 50-70
	高合金钢 High alloy steel	退火 Anneal 淬硬 Hardened	200-325	90-115 70-90	80-110 60-80
	铸钢 Cast steel	非合金 Non-alloy 低合金 Low-alloy 高合金 High-alloy 马氏体钢12%Mn Martensite steel 12%Mn	180-250	180-210 90-115 90-115 40-50	160-200 80-110 80-110 30-40
M	不锈钢 Stainless steel	奥氏体 Austenite	180	110-130	100-120
		马素体/铁素体 Martensite/Ferrite	200	130-170	120-160
K	可锻铸铁 Malleable cast iron	铁素体 Ferrite 珠光体 Pearlite	130-230	110-140 85-105	100-130 70-100
	灰口铸铁 Gray cast iron	低拉伸强度 Low tensile-strength 高拉伸强度 High tensile-strength	180-260	110-140 90-115	100-130 80-110
N	球墨铸铁 Nodular cast iron	铁素体 Ferrite 珠光体 Pearlite	160-250	110-130 80-100	100-120 60-90
		铝合金 Al alloy	未时效处理 Non-aging treatment 时效处理 Aging treatment	60-100	1300-1450 450-500
S	铸铝合金 Cast aluminum alloy	未时效处理 Non-aging treatment 时效处理 Aging treatment	75-90	430-470 250-290	350-450 200-260
		耐热合金 Heat resistant alloy	镍基 Ni-base 镍基或钴基 Ni- or Co-base	退火 Anneal 时效 Aging 退火 Anneal 时效 Aging 铸造 Casting	200-280 250-350
H	淬火钢 Hardened steel	淬火钢 Hardened steel	HRC55	40-50	30-40

注 Note:

- ★ 上表为范围值，实际切削时，可适当取高值，当试用新切削速度时，应仔细查看切削刃的状况。
The values in the above table are range values. High values in the range could be considered in actual cutting. When trying new cutting speed, please check the cutting edge condition before operation.
- ★ 进行不锈钢螺纹切削时，应使用足够高的切削速度，以避免“积屑瘤”的形成。
In stainless steel threading, high cutting speed should be used to prevent built-up edge.
- ★ 当切削小螺距螺纹和使用小刀尖半径刀具时，应适当减小切削参数。
The cutting parameters should be reduced when cutting small pitch thread and when using tools with small nose radius.



切断切槽车削系列
Parting and Grooving Inserts

切断切槽刀片型号命名规则

Naming Rule of Parting and Grooving Inserts

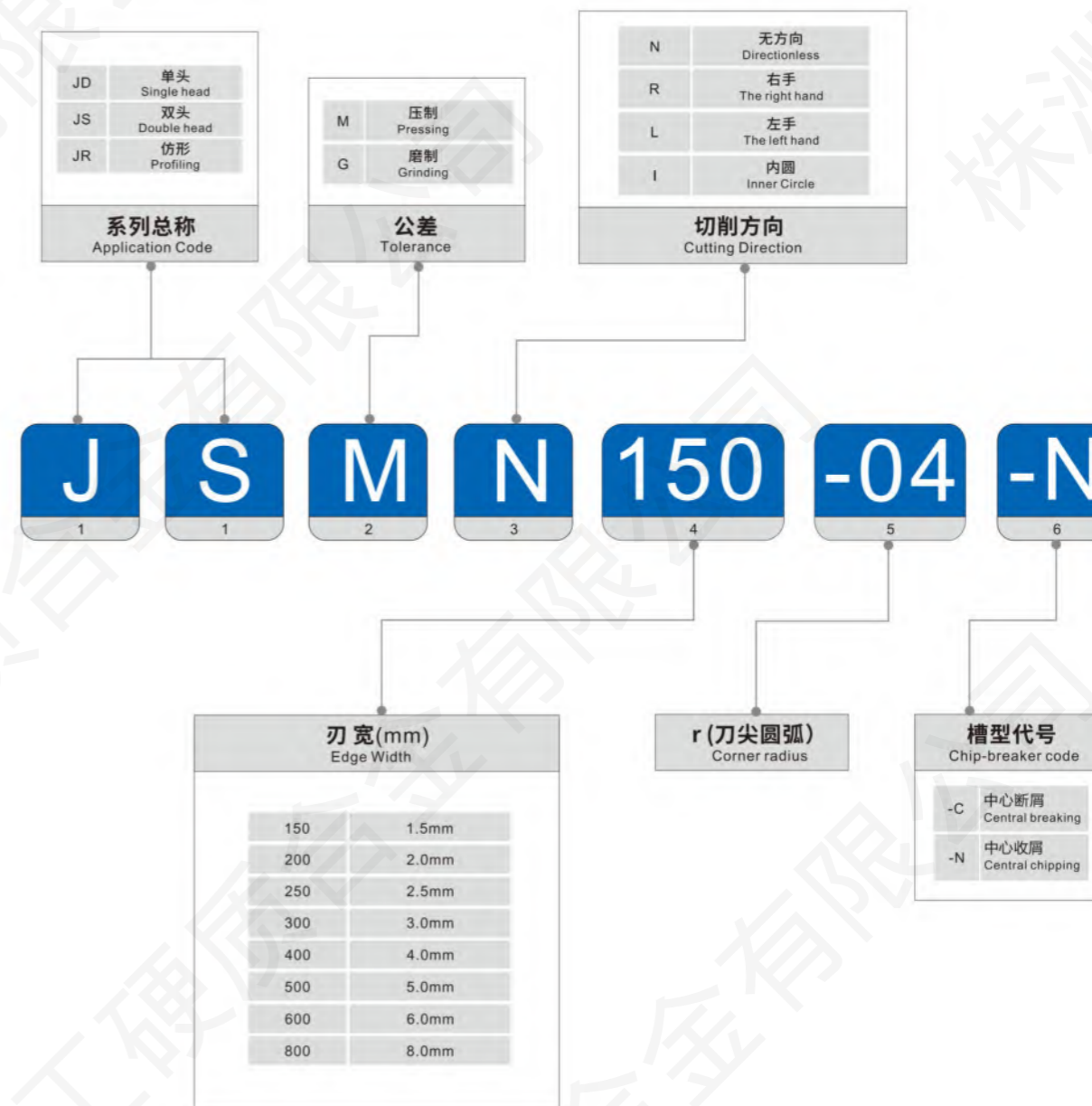

切断切槽车削刀片 Parting and Grooving Inserts

切断切槽刀片特点

The features of parting and grooving inserts

刀片能够用于切槽和车削加工，是一款多功能通用加工刀片；
优化的三维切屑槽型对切屑实现有效控制，最大限度降低了切削阻力，减小了加工振动；
槽加工专门开发的硬质合金基体和涂层的结合，兼备了耐磨性和韧性，提高了加工寿命和加工的可靠性。

The inserts is a multifunctional general-purposed machining inserts, which can be used for grooving and turning;
The optimized 3D chip-breakers can effectively control chip-breaking, minimize the cutting resistance and reduce the machining vibration;
The combination of carbide matrix and coating specially developed for processing chip-breakers, has both wear resistance and toughness, and improves the processing life and reliability.

槽型特点

Characteristics of Chip-breakers

-C

满足切断、切槽、车削等各种加工需要，切削过程变得轻松，排屑更为流畅，达到理想的加工表面质量。

To meet different needs of cutting, grooving, turning and etc, the cutting process becomes easier, the chip-breaking effect is good, and the ideal machining surface quality is achieved.

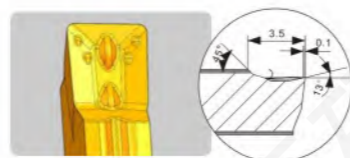

-N

特殊的后刀面结构使切削阻力降低20%，减少振动，进一步提高表面质量。特殊的刃口设计使断屑效果更好，可以横向走刀。

The special flank structure reduces the cutting resistance by 20%, reduces vibration and further improves the surface quality.
The special cutting edge design makes the chip-breaking effect better, and the tool can be moved horizontally.

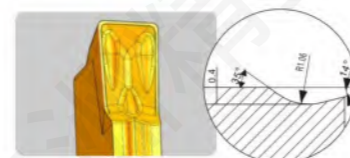

加工方式

Processing methods

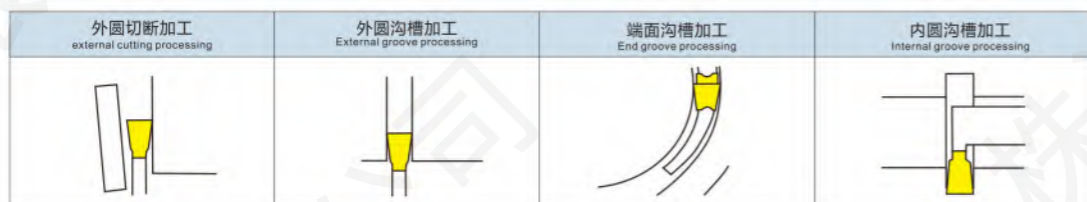

切断切槽车削刀片 Parting and Grooving Inserts

JSMN/JRMN

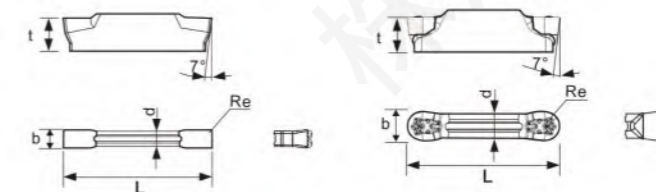

刀片外形 Inserts Shape	型号 Type	基本尺寸 Dimension(mm)					牌号 Grade									
		b	Re	L	d	t	P		M	K	H	金陶 Cermet				
							JGP15S	JGP25S	JGP25T	JGP40S	JGA20F	JGA10A	JGM20R	JGK10R	JGA05A	JTN20
	JSMN150-02-N	1.50	0.15	16.0	1.2	3.5			●	○						
	JSMN200-02-N	2.00	0.20	16.0	1.6	3.5			●	○						
	JSMN250-02-N	2.50	0.20	18.5	2.0	3.85			●	○						
	JSMN300-04-C	3.00	0.40	21.0	2.35	4.8			●	○						
	JSMN400-04-C	4.00	0.40	21.0	3.3	4.8			●	○						
	JSMN500-08-C	5.00	0.80	26.0	4.1	5.8			●	○						
	JSMN600-08-C	6.00	0.80	26.0	4.1	5.8			●	○						
	JRMN200-10-C	2.00	1.00	16.0	1.50	3.5			●	○						
	JRMN300-15-C	3.00	1.50	21.0	2.35	4.8			●	○						
	JRMN400-20-C	4.00	2.00	21.0	3.3	4.8			●	○						
	JRMN500-25-C	5.00	2.50	26.0	4.1	5.8			●	○						
	JRMN600-30-C	6.00	3.00	26.0	4.1	5.8			●	○						
	JRMN800-40-C	8.00	4.00	31.0	4.1	6.5			●	○						

● 主推牌号 Main recommended grades ○ 一般牌号 General grades ○ 可生产牌号 Available grades

切断切槽车削加工案例

Parting and Grooving Inserts Application Cases

切断切槽加工

Parting and Grooving processing

- ▶ 被加工材料 Processed material: 42CrMo
- ▶ 加工方式 Processing methods: 连续切削外圆槽 Continuous External Turning
- ▶ 使用刀片 Use of inserts: JSMN250-02-N/JGA10A
- ▶ 加工参数 Processing parameters: $V_c=110\text{m/min}$, $f=0.16\text{mm/r}$

切削性能 Cutting Performance	
精工寿命 Life time of ZZJG inserts	280件/刃 Pieces/edge
国外某品牌 Life time of another brand	330件/刃 Pieces/edge

在同等加工条件下, 我司N槽型排屑好, 切削轻快, 性价比优势明显。

Under the same processing conditions, our N type chip-breaker has good chip-breaking effect and cut easier. Cost-effective advantage is obvious.

切槽 Grooving

- ▶ 被加工材料 Processed material: 45#钢 45#steel
- ▶ 加工方式 Processing methods: 车削外圆加工 External Turning Processing
- ▶ 使用刀片 Use of inserts: JSMN300-04-C/JGA20F
- ▶ 加工参数 Processing parameters: $V_c=128\text{m/min}$, $f=0.22\text{mm/r}$

切削性能 Cutting Performance	
精工寿命 Life time of ZZJG inserts	160件/刃 Pieces/edge
国外某品牌 Life time of another brand	160件/刃 Pieces/edge

在同等加工条件下, 我司JSMN刀片切削轻快, 断屑能力相当, 性价比优势明显。

Under the same processing conditions, our JSMN insert has good chip breaking effect and cut easier. Cost-effective advantage is obvious.

仿形 Profiling

- ▶ 被加工材料 Processed material: 45#钢 45#steel
- ▶ 加工方式 Processing methods: 车削外圆加工 External Turning Processing
- ▶ 使用刀片 Use of inserts: JRMN400-20-C/JGP25T
- ▶ 加工参数 Processing parameters: $V_c=220\text{m/min}$, $f=0.18\text{mm/r}$

切削性能 Cutting Performance	
精工寿命 Life time of ZZJG inserts	100件/刃 Pieces/edge
国外某品牌 Life time of another brand	100件/刃 Pieces/edge

C槽型切削轻快, 优良的槽型结构排屑效果良好, 性价比优势明显。

C type chip breaker has good chip-breaking effect and cut easier. Cost-effective advantage is obvious.

切断切槽刀具切削用量推荐表

Table of recommended cutting parameters for parting and grooving

刀片尺寸 Insert size	进给量推荐 Recommended rate(mm/r)				
	刀片宽度 Insert width (mm)	切断 Parting	切槽 Grooving	车削 Turning	仿形 Profiling
2.5		0.05-0.15	0.05-0.15	0.05-0.15	0.05-0.15
3		0.05-0.15	0.05-0.15	0.07-0.15	0.1-0.2
4		0.05-0.2	0.05-0.2	0.07-0.25	0.1-0.2
5		0.07-0.2	0.07-0.22	0.1-0.25	0.15-0.3
6		0.1-0.3	0.07-0.25	0.1-0.3	0.15-0.3

工件材料 Workpiece material		硬度 Hardness	JGA20F	JGA10A	JGP25T
P	碳钢 Carbon steel	125≤HB≤170	120-260	150-280	150-280
	低合金钢 Low alloy steel	180≤HB≤275	80-175	110-200	110-200
	高合金钢 High alloy steel	180≤HB≤325	80-160	110-190	110-190
M	铸钢 Cast steel	180≤HB≤250	75-140	100-170	100-170
	铁素体、马氏体 Ferrite/Martensite	200≤HB≤300	70-170	100-200	100-200
	奥氏体 Austenite	180≤HB≤300	80-200	110-220	110-220
K	可锻铸铁 Malleable cast iron	130≤HB≤230	100-200	130-220	
	灰口铸铁 Gray cast iron	180≤HB≤220	90-170	120-200	
	球墨铸铁 Nodular cast iron	160≤HB≤250	80-150	110-180	
N	铝合金 Al alloy	--			
S	高温合金 Heat-resisting alloy	≤400			

切削用量适用于湿式加工。The cutting parameters recommended are suitable for wet machining.

建议: 内圆切削和端面切削, 速度应降低30%-40%。Advice: internal machining and end machining, The cutting speed should be reduced by 30%-40%.

车削加工常见问题及解决方案 Common Problems and Solutions In Turning

常见问题 Main problem	选择条件 Selection condition	刀具材料选择 Selection of Tool material		切削条件 Cutting Condition	
		硬度更高的材料 Material with higher hardness	韧性好的材料 Material with good toughness	切削速度 Cutting speed	进给 Feeding
刀尖磨损过大 Too much wear for the knife point	加工中精度超标 Machining accuracy beyond standard	后刀面磨损增大 Flank wear increases	✓		
表面精度恶化 Surface accuracy deterioration	表面质量差 Poor surface quality	切削条件不适合 Cutting condition is not suitable		↓	↑
		刀具磨损增大、刀刃不够锋利 Tool wear increases and the blade is not sharp enough	✓	↓	
		切削刃缺损 Cutting edge defect		✓	↓
		切削刃几何形状不合适 Cutting edge geometry is not appropriate			↓
		切削条件不合适 Cutting condition is not suitable		↑	↓
发热 Heat	切削热的影响 Cutting heat effect	振动、发颤 Vibration and tremble		✓	↓
		积屑瘤 built-up edge		↑	↑
尺寸精度差 Poor dimensional accuracy	加工中尺寸波动 Dimension fluctuation in machining	切削条件不合适 Cutting condition is not suitable		↓	
		切削刃几何形状不合适 Cutting edge geometry is not appropriate	✓		
刀具切削刃损伤 Cutting edge damage	后刀面、前刀面磨损增大 Wear increases on the back and front knife surfaces	刀片精度不合适 The blade accuracy is not suitable			↑
		工件、刀具位置偏移 Work tool offset		↑	
		后刀面磨损 The front edge wears	✓	↓	
	微崩 Minor Tipping	前刀面磨损 The back edge wears	✓	↓	↓
		振动、冲击 Vibration and impact		✓	↓
	积屑瘤 Built-up edge	工件硬度与刀具切削条件不适合 The hardness of the tool material is not suitable for cutting condition			↑
		热龟裂 Thermal cracking	工件材料的硬度与刀具材料和切削条件不适合 The hardness of the tool material is not suitable for cutting condition		↓
切削刃刀尖部分变形 Cutting edge deformation	刀具寿命 Life time of tools	在断续切削大进给时发生 Occurs when intermittent cutting in large feeding	✓	↓	↓
		材料、切削条件不合适 Tool material is not suitable for cutting condition		✓	↓
		切削条件不合适 Cutting condition is not suitable		↓	↑
切屑控制 Cutting control	长切屑缠绕 long cutting chips, winding	刀具几何形状不合适 Cutting edge geometry is not appropriate		↓	↑
		切削条件不合适 Cutting condition is not suitable		↓	↓
毛刺、塌边 Burr, Collapse	钢、铝，产生毛刺 Steel and aluminum, burrs	切削条件不合适 Cutting condition is not suitable		↑	↓
		刀具磨损、几何形状不合适 Cutting tool wears and Cutting edge geometry is not appropriate	✓		
	铸铁，塌边 Cast iron, collapse	切削条件不合适 Cutting condition is not suitable		↓	↑
刀具磨损、几何形状不合适 Cutting tool wears and Cutting edge geometry is not appropriate		✓			
软钢，毛边 Mild steel, burrs	切削条件不合适 Cutting condition is not suitable				↓
		刀具磨损、几何形状不合适 Cutting tool wears and Cutting edge geometry is not appropriate	✓		

切削条件 Cutting Condition		刀具形状 Shape of tool					机床装夹 Machine tool clamping				
切深 Cutting depth	切削液 Cutting fluid	改变刀片槽型 Change chip breakers of the inserts	前角 Front angle	刀尖圆弧半径 Corner radius	主偏角 Cutting edge angle	切削刃强度 Cutting edge strength	提高刀片精度 Improve blade accuracy	提高刀具刚性 Improve blade rigidity	工件刀柄装夹 Workpiece holder clamping	刀柄悬伸 Tool holder overhanging	动力、机床间隙 Power machine clearance
				↑							
	✓		↑	↑		↓	✓		✓	✓	✓
↓		✓		↑		↑					
↓	✓	✓		↑		↓	✓				
↓	✓	✓	↑	↓	↑	↓			✓	✓	✓
	✓	✓	↑			↓	✓				
		✓	↑	↓	↑			✓	✓	✓	✓
↓		✓	↑	↑		↓					
↓	✓	✓	↑		↓	↓					
↓	✓	✓	↑	↑	↓	↑		✓	✓	✓	✓
↑	✓			↓	↑						
↓	✓			↑	↓						
	✓	✓	↑	↓	↑	↓					
↓		✓	↑	↑		↑		✓	✓	✓	✓



外圆车削系列
External Turning Tool

外圆车刀杆命名规则
Naming Rules of External Turning Tool Holders

A-type型号	E-type型号	Q-type型号
C-type型号	JS-type型号	P-type型号
D-type型号	M-type型号	S-type型号
夹紧方式 Fastening mode		

A		F		K		P		X	
B		G		L		Q		Y	
C		J		L2		S		Z	
D		J2		N		V			
E		N3		U					
切入角 Cut-in angle									



C		四边形 顶角80° Quadrangle Vertex angle80°
D		四边形 顶角55° Quadrangle Vertex angle55°
K		平行四边形 顶角55° Parallelogram Vertex angle55°
R		圆形 Round
S		正方形 Square
T		正三角形 Regular triangle
V		四边形 顶角35° Quadrangle Vertex angle35°
W		特殊六边形 Special hexagon
刀片形状 Shape of blade		

C		7°
B		5°
N		0°
P		11°
刀片间隙角 Relief angle of blade		

L	
N	
R	
方向 Direction	



H	100
K	125
M	150
P	170
R	200
长度(mm) Length	

内切圆直径 Diameter of inscribed circle(mm)	
3	9.525
4	12.7
5	15.875
6	19.05
8	25.4
切刃长(mm) Length of cutting blade	

外圆车刀杆系列

Series of External Turning Tool Holders

MCFNR/L

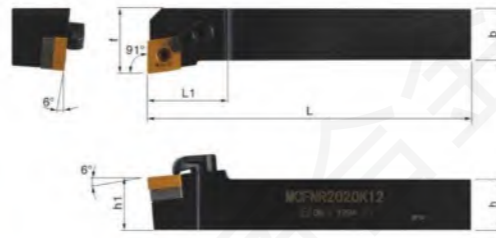

型号 Type	适用刀片 Adaptable Inserts	基本尺寸 Dimension(mm)						刀垫 Shim	销钉 Pin	压板 Clamp	双头螺丝 Screw	扳手 Wrench
		h	b	L	L1	h1	f					
MCFNR/L2020K12		20	20	125	32	20	25					
MCFNR/L2525M12	CN□□1204□□	25	25	150	32	25	32	MC1204	CTM617	HL1813	ML0625	L3.0
MCFNR/L3232P12		32	32	170	32	32	40					
MCFNR/L3232P19	CN□□1906□□	32	32	170	36	32	40	MC1904	CTM1022	HL2217	ML0830	L4.0

型号 Type	适用刀片 Adaptable Inserts	基本尺寸 Dimension(mm)						刀垫 Shim	压板螺钉 Plate screws	压板 Clamp	刀垫螺钉 Shim screw	扳手 Wrench
		h	b	L	L1	h1	f					
DCFNR/L2020K12		20	20	125	32	20	25					
DCFNR/L2525M12	CN□□1204□□	25	25	150	32	25	32	MC1204	M6×21	HLD-1	M6×9P	L3.0
DCFNR/L3232P12		32	32	170	32	32	40					

外圆车刀杆系列

Series of External Turning Tool Holders

MCLNR/L

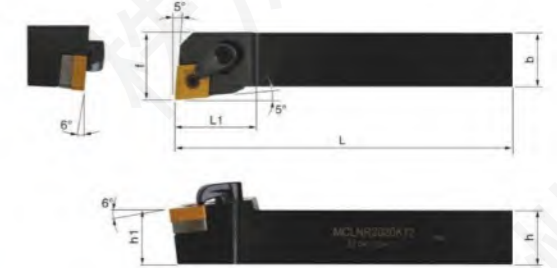

型号 Type	适用刀片 Adaptable Inserts	基本尺寸 Dimension(mm)						刀垫 Shim	销钉 Pin	压板 Clamp	双头螺丝 Screw	扳手 Wrench
		h	b	L	L1	h1	f					
MCLNR/L2020K12		20	20	125	30	20	25					
MCLNR/L2525M12	CN□□1204□□	25	25	150	31	25	32	MC1204	CTM617	HL1813	ML0625	L3.0
MCLNR/L3232P12		32	32	170	33	32	40					
MCLNR/L2525M16	CN□□1606□□	25	25	150	37	25	40	MC1604	CTM822	HL2217	ML0830	L3.0 L4.0
MCLNR/L3232P16		32	32	170	36	32	40					
MCLNR/L3232P19	CN□□1906□□	32	32	170	39	32	40	MC1904	CTM1022	HL2217	ML0830	L4.0

型号 Type	适用刀片 Adaptable Inserts	基本尺寸 Dimension(mm)						刀垫 Shim	压板螺钉 Plate screws	压板 Clamp	刀垫螺钉 Shim screw	扳手 Wrench
		h	b	L	L1	h1	f					
DCLNR/L2020K12		20	20	125	32	20	25					
DCLNR/L2525M12	CN□□1204□□	25	25	150	32	25	32	MC1204	M6×21	HLD-1	M6×9P	L3.0
DCLNR/L3232P12		32	32	170	33	32	40					

外圆车刀杆系列

Series of External Turning Tool Holders

MTFNR/L

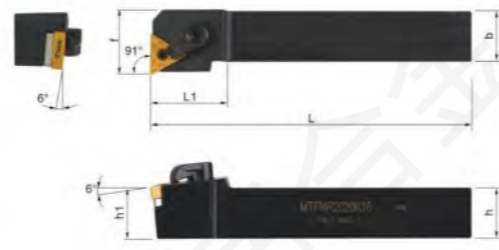

外圆车刀杆系列

Series of External Turning Tool Holders

MTGNR/L

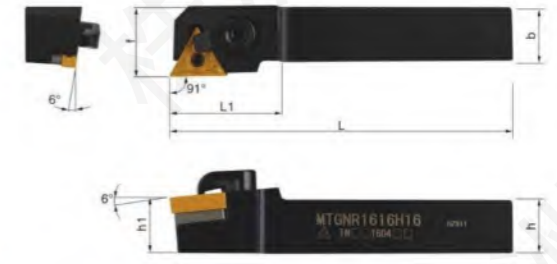
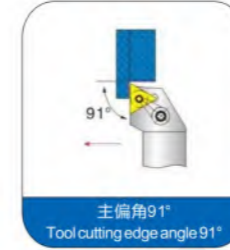

型号 Type	适用刀片 Adaptable Inserts	基本尺寸 Dimension(mm)						刀垫 Shim	销钉 Pin	压板 Clamp	双头螺丝 Screw	扳手 Wrench
		h	b	L	L1	h1	f					
MTFNR/L2020K16	TN□□1604□□	20	20	125	29	20	25	MT1603	CTM513	HL1813	ML0625	L2.0 L3.0
MTFNR/L2525M16		25	25	150	31	25	32					
MTFNR/L3232P16		32	32	170	32	32	40					
MTFNR/L2525M22	TN□□2204□□	25	25	150	36	25	32	MT2204	CTM617	HL1917	ML0830	L3.0 L4.0
MTFNR/L3232P22		32	32	170	36	32	40					

型号 Type	适用刀片 Adaptable Inserts	基本尺寸 Dimension(mm)						刀垫 Shim	销钉 Pin	压板 Clamp	双头螺丝 Screw	扳手 Wrench
		h	b	L	L1	h1	f					
MTGNR/L2020K16	TN□□1604□□	20	20	125	29	20	25	MT1603	CTM513	HL1813	ML0625	L2.0 L3.0
MTGNR/L2525M16		25	25	150	30	25	32					
MTGNR/L3232P22		32	32	170	32	32	40					

型号 Type	适用刀片 Adaptable Inserts	基本尺寸 Dimension(mm)						刀垫 Shim	压板螺钉 Plate screws	压板 Clamp	刀垫螺钉 Shim screw	扳手 Wrench
		h	b	L	L1	h1	f					
DTFNR/L2020K16	TN□□1604□□	20	20	125	32	20	25	MT1603	M6×21	HLD-3	M5×9P	L3.0
DTFNR/L2525M16		25	25	150	31	25	32					
DTFNR/L3232P16		32	32	170	31	32	40					

型号 Type	适用刀片 Adaptable Inserts	基本尺寸 Dimension(mm)						刀垫 Shim	压板螺钉 Plate screws	压板 Clamp	刀垫螺钉 Shim screw	扳手 Wrench
		h	b	L	L1	h1	f					
DTGNR/L2020K16	TN□□1604□□	20	20	125	29	20	25	MT1603	M6×21	HLD-3	M5×9P	L3.0
DTGNR/L2525M16		25	25	150	30	25	32					
DTGNR/L3232P22		32	32	170	32	32	40					

外圆车刀杆系列

Series of External Turning Tool Holders

MTJNR/L



外圆车刀杆系列

Series of External Turning Tool Holders

MWLNR/L

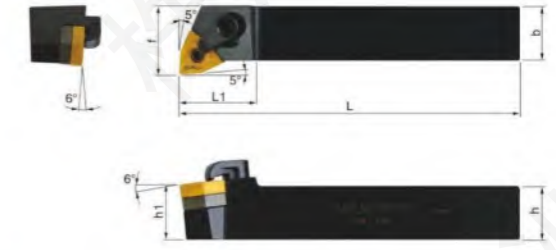

型号 Type	适用刀片 Adaptable Inserts	基本尺寸 Dimension(mm)						刀垫 Shim	销钉 Pin	压板 Clamp	双头螺丝 Screw	扳手 Wrench
		h	b	L	L1	h1	f					
MTJNR/L2020K16	TN□□1604□□	20	20	125	32	20	25	MT1603	CTM513	HL1813	ML0625	L2.0 L3.0
MTJNR/L2525M16		25	25	150	34	25	32					
MTJNR/L3232P16		32	32	170	36	32	40					
MTJNR/L2020K22	TN□□2204□□	20	20	125	37	20	25	MT2204	CTM617	HL1917	ML0830	L3.0 L4.0
MTJNR/L2525M22		25	25	150	38	25	32					
MTJNR/L3232P22		32	32	170	40	32	40					

型号 Type	适用刀片 Adaptable Inserts	基本尺寸 Dimension(mm)						刀垫 Shim	销钉 Pin	压板 Clamp	双头螺丝 Screw	扳手 Wrench
		h	b	L	L1	h1	f					
MWLNR/L2020K06	WN□□0604□□	20	20	125	26	20	25	MW0603	CTM513	HL1813	ML0625	L2.0 L3.0
MWLNR/L2525M06		25	25	150	32	25	32					
MWLNR/L3232P06		32	32	170	40	32	40					
MWLNR/L2020K08	WN□□0804□□	20	20	125	28	20	25	MW0804	CTM617	HL1813	ML0625	L3.0
MWLNR/L2525M08		25	25	150	32	25	32					
MWLNR/L3232P08		32	32	170	32	32	40					

型号 Type	适用刀片 Adaptable Inserts	基本尺寸 Dimension(mm)						刀垫 Shim	压板螺钉 Plate screws	压板 Clamp	刀垫螺钉 Shim screw	扳手 Wrench
		h	b	L	L1	h1	f					
DWLNR/L2020K06	WN□□0604□□	20	20	125	26	20	25	MW0603	M6×21	HLD-3	M5×9P	L3.0
DWLNR/L2525M06		25	25	150	32	25	32					
DWLNR/L3232P06		32	32	170	40	32	40					
DWLNR/L2020K08	WN□□0804□□	20	20	125	28	20	25	MW0804	M6×21	HLD-1	M6×9P	L3.0
DWLNR/L2525M08		25	25	150	32	25	32					
DWLNR/L3232P08		32	32	170	32	32	40					



内孔车削系列
Internal turning tool

内孔车刀杆命名规则
Naming Rules of Internal Turning Tool Holders



内孔车刀杆系列

Series of Internal Turning Tool Holders

MCLNR/L

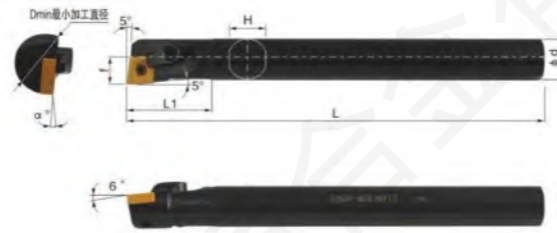
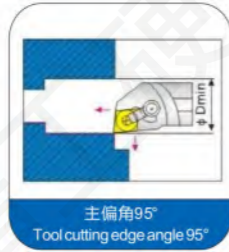

内孔车刀杆系列

Series of Internal Turning Tool Holders

MTFNR/L

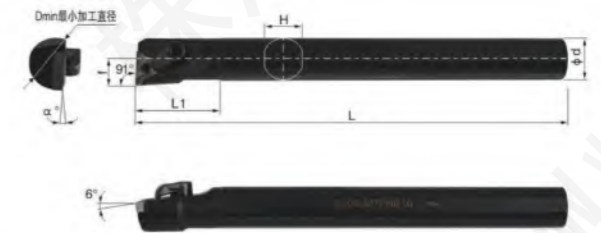
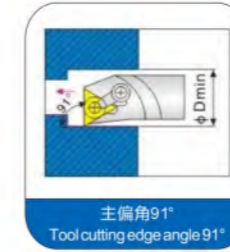

型号 Type	适用刀片 Adaptable Inserts	基本尺寸 Dimension(mm)							刀垫 Shim	销钉 Pin	压板 Clamp	双头螺丝 Screw	扳手 Wrench
		ΦDmin	φd	L	L1	H	f	α°					
S16Q-MCLNR/L12		20	16	180	35	14.8	11	18°					
S20R-MCLNR/L12	CN□□1204□□	25	20	200	45	19	13	15°		CTM613	HL1810	ML0620	L3.0
S25S-MCLNR/L12		29	32	250	45	24	15	12°					

型号 Type	适用刀片 Adaptable Inserts	基本尺寸 Dimension(mm)							刀垫 Shim	销钉 Pin	压板 Clamp	双头螺丝 Screw	扳手 Wrench
		ΦDmin	φd	L	L1	H	f	α°					
S16Q-MTFNR/L16		20	16	180	35	15	11	15°					
S20R-MTFNR/L16	TN□□1604□□	25	20	200	40	19	13	15°		CTM511	HL1810	ML0620	L2.0 L3.0
S25S-MTFNR/L16		30	25	250	45	24	15.5	15°					

型号 Type	适用刀片 Adaptable Inserts	基本尺寸 Dimension(mm)							刀垫 Shim	压板螺钉 Plate screws	压板 Clamp	弹簧 Spring	扳手 Wrench
		ΦDmin	φd	L	L1	H	f	α°					
S20R-DCLNR/L12	CN□□1204□□	25	20	200	45	19	13	15°					
S25S-DCLNR/L12		29	25	250	45	24	15	12°		M6×21	HLD-1	TH810	L3.0

型号 Type	适用刀片 Adaptable Inserts	基本尺寸 Dimension(mm)							刀垫 Shim	压板螺钉 Plate screws	压板 Clamp	弹簧 Spring	扳手 Wrench
		ΦDmin	φd	L	L1	H	f	α°					
S16Q-DTFNR/L16		20	16	180	35	15	11	15°					
S20R-DTFNR/L16	TN□□1604□□	25	20	200	40	19	13	15°		M6×21	HLD-3	TH810	L3.0
S25S-DTFNR/L16		30	25	250	45	24	15.5	12°					

内孔车刀杆系列

Series of Internal Turning Tool Holders

MTUNR/L

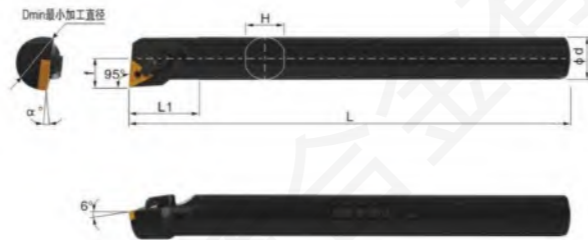

型号 Type	适用刀片 Adaptable Inserts	基本尺寸 Dimension(mm)							刀垫 Shim	销钉 Pin	压板 Clamp	双头螺丝 Screw	扳手 Wrench
		ΦDmin	Φd	L	L1	H	f	α°					
S16Q-MTUNR/L16	TN□□1604□□	20	16	180	40	15	11	15°					
S20R-MTUNR/L16		25	20	200	40	13	13.5	15°					
S25S-MTUNR/L16		30	25	250	45	24	15.5	12°					

型号 Type	适用刀片 Adaptable Inserts	基本尺寸 Dimension(mm)							刀垫 Shim	压板螺钉 Plate screws	压板 Clamp	弹簧 Spring	扳手 Wrench
		ΦDmin	Φd	L	L1	H	f	α°					
S16Q-DTUNR/L16	TN□□1604□□	20	16	180	40	15	11	15°					
S20R-DTUNR/L16		25	20	200	40	13	13.5	15°					
S25S-DTUNR/L16		30	25	250	45	24	15.5	12°					

内孔车刀杆系列

Series of Internal Turning Tool Holders

MWLNR/L

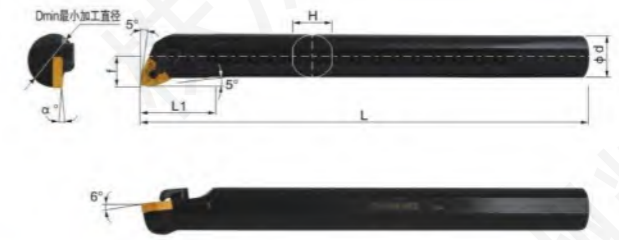
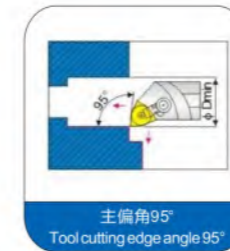

型号 Type	适用刀片 Adaptable Inserts	基本尺寸 Dimension(mm)							刀垫 Shim	销钉 Pin	压板 Clamp	双头螺丝 Screw	扳手 Wrench
		ΦDmin	Φd	L	L1	H	f	α°					
S16Q-MWLNR/L06	WN□□0604□□	20	16	180	35	15	11	18°					
S20R-MWLNR/L06		24	20	200	40	19	13	15°					
S25S-MWLNR/L06		32	25	250	45	23	17	12°					
S16Q-MWLNR/L08	WN□□0804□□	20	16	180	35	15	11	15°					
S20R-MWLNR/L08		25	20	200	40	19	13	15°					
S25S-MWLNR/L08		30	25	250	36	23	16.5	12°					

型号 Type	适用刀片 Adaptable Inserts	基本尺寸 Dimension(mm)							刀垫 Shim	压板螺钉 Plate screws	压板 Clamp	弹簧 Spring	刀垫螺钉 Shim screw	扳手 Wrench
		ΦDmin	Φd	L	L1	H	f	α°						
S20R-DWLNR/L06	WN□□0604□□	24	20	200	40	19	13	15°						
S25S-DWLNR/L06		32	25	250	45	23	17	12°						
S20R-DWLNR/L08	WN□□0804□□	25	20	200	40	19	13	15°						
S25S-DWLNR/L08		30	25	250	36	23	16.5	12°						



P84

P84

P81

P82

P83

P83



P85



P97



P94



P92

铣削

Milling Tools



铣削刀片牌号一览表	77
Grades Table for Milling Inserts	
普通铣削刀片型号命名规则	79
Naming Rules of Milling Inserts	
普通铣削刀片	81
General Milling Inserts	
铣削刀片加工案例	99
Application Cases for Milling	
铣削加工常见问题及解决方案	101
Common Problems and Solutions In Milling	

铣削产品牌号一览表
Grades Table for Milling Inserts

工件材料 Workpiece materials	ISO代号 ISO Code	涂层 Coating		金属陶瓷 Cermet	硬质合金 Cemented carbide
		CVD	PVD		
P 钢件 Steel	P01				
	P10		JGA05A JGA20F JGA20H JGA10A	JTN20	
	P20			JTN35	
	P30		JGA30F		
	P40				
M 不锈钢 Stainless Steel	M01				
	M10		JGA10A		
	M20	JGM20R JGM30R	JGA30A JGA30F	JTN20	JTN35
	M30				
	M40				
K 铸铁 Cast Iron	K01				
	K10	JGK15R			
	K20				
	K30				
N 有色金属 Non-Ferrous Metal	N01				
	N10				JS10A JS20A
	N20				
	N30				
S 钛合金 耐热合金 Titanium Alloy Heat-Resisting Alloy	S01				
	S10		JGS20A JGS20C		
	S20				
	S30				
H 高硬度材料 High Hardness Material	H01				
	H10		JGA05A		
	H20				
	H30				



方肩AP系列

Square shoulder milling inserts
---AP series

我们重点

新增开发几个系列铣削产品，
完善优化产品结构和工艺，
进一步提升了铣削刀片的产品性能。

We focus on the development
of several new series of milling products,
Optimization of product structure and process,
and further improvement of performance
of the milling inserts.

大进给SD、SO系列

Large feed milling inserts--
SD, SO series



面铣SN、WN、XN系列

Face milling inserts--SN, WN,
XN series

仿形RC、RP系列

Profile milling inserts---RC,
RP series



P82

普通铣削刀片型号命名规则 Naming Rules of Milling Inserts

刀片形状/代号 Shape of inserts/code				
A 85°	B 82°	C 80°	D 55°	E 75°
H 120°	K 55°	L 90°	M 86°	O 135°
P 108°	R 360°	S 90°	T 60°	T 75°
V 35°	W 80°	Z 其他 Others		
形状代号 Code of insert shape				

公制 Metric system							
代号 Code	有无孔 With/ Without hole	有无断屑槽 With/Without chipbreaker	刀片剖面 Section plane of insert	代号 Code	有无孔 With/ Without hole	有无断屑槽 With/Without chipbreaker	刀片剖面 Section plane of insert
B	有 With	无 Without		N	无 Without	无 Without	
H	有 With	单面 Single-side		R	无 Without	单面 Single-side	
C	有 With	无 Without		F	无 Without	双面 Double-side	
J	有 With	双面 Double-side		A	有 With	无 Without	
W	有 With	无 Without		M	有 With	单面 Single-side	
T	有 With	单面 Single-side		G	有 With	双面 Double-side	
Q	有 With	无 Without		X	—	—	特殊 Special
U	有 With	双面 Double-side					
断屑槽及夹固形式 Chip-breaking groove and clamping form							

内切圆直径 Diameter or IC (mm)	刀片形状 Shape of inserts						
	C	D	R	S	T	V	W
3.97					06		
5.0							
5.56			05		09		
6.0							
6.35	06	07			11	11	
8.0			06				
9.525	09	11	09	09	16	16	06
10.0			10				
12.0			12				
12.7	12	15	12	12	22	22	08
15.875	16	15	15	15	27		
16.0		19	16				
19.05	19	19	19	19	33		
20.0			20				
25.0	25	25	25	25			
25.4			25	25			
31.75			31				
32			32				
切削刃长度 Length of cutting edge							

代号 Code	刀片厚度 Thickness (mm)
00	0.79
T0	0.99
01	1.59
T1	1.98
02	2.38
T2	2.58
03	3.18
T3	3.97
04	4.76
T4	4.96
05	5.56
T5	5.95
06	6.35
T6	6.75
07	7.94
09	9.52
T9	9.72
11	11.11
12	12.70

厚度指刀片底面与切削刃最高部分之间的高度
Thickness is defined as the height from the bottom of insert to the highest part of cutting edge

刀片厚度
Thickness of inserts

S P K N

12 04 ED T21 R - NR8

主切削刃后角 Clearance angle of main cutting edge			
代号 Code	后角(度) Clearance angle	代号 Code	后角(度) Clearance angle
A	3°	B	5°
C	7°	D	15°
E	20°	F	25°
G	30°	N	0°
P	11°	O	其他后角 Other Clearance angle

公差 Tolerance								
代号 Code	刀尖高度m 公差 (mm) Nose height m Tolerance (mm)	内切圆∅I.C 公差 (MM) Inscribed circle ∅I.C Tolerance (mm)	厚度S _t 公差 (mm) Thickness S _t Tolerance (mm)	(参考)M级精度详细情况 (按形状、大小分) (Reference)Details of M-level tolerance (identified by shape)				
				● 刀尖高度公差 Nose height tolerance (mm)				
				内切圆 Inscribed circle	正三角形 Regular triangle	正方形 Square	80°菱形 Diamond with 80°	
A	±0.005	±0.025	±0.025	6.35	±0.08	±0.08	±0.08	
F	±0.005	±0.013	±0.025	9.525	±0.08	±0.08	±0.11	
C	±0.013	±0.025	±0.025	12.7	±0.13	±0.13	±0.15	
H	±0.013	±0.013	±0.025	15.875	±0.15	±0.15	±0.18	
E	±0.025	±0.025	±0.025	19.05	±0.15	±0.15	±0.18	
G	±0.025	±0.025	±0.13	25.4	—	±0.18	—	
J	±0.005	±0.05±0.13	±0.025	25.4	—	—	—	
K	±0.013	±0.05±0.13	±0.025					
L	±0.025	±0.05±0.13	±0.025					
M	±0.08±0.18	±0.05±0.13	±0.13					
N	±0.08±0.18	±0.05±0.13	±0.025					
U	±0.08±0.18	±0.08±0.25	±0.13					
				● 内切圆∅I.C公差 Tolerance of inscribed circle ∅I.C (mm)				
				内切圆 Inscribed circle	正三角形 Regular triangle	正方形 Square	80°菱形 Diamond with 80°	
					55°菱形 Diamond with 55°	35°菱形 Diamond with 35°	圆形 Round	
				6.35	±0.05	±0.05	±0.05	—
				9.525	±0.05	±0.05	±0.05	±0.05
				12.7	±0.08	±0.08	±0.08	—
				15.875	±0.10	±0.10	±0.10	±0.10
				19.05	±0.10	±0.10	±0.10	±0.10
				25.4	—	±0.13	—	±0.13

修光刃 Smoothing edge	
A	45°
D	60°
E	75°
F	85°
P	90°
Z	其他 Others

切削刃倒棱 (mm) Chamfering cutting edge		
F	0-5°	0-0.10
E	1-10°	1-0.15
T	2-15°	2-0.20
T	3-20°	3-0.25
T	4-25°	4-0.30
S	5-30°	5-0.35
S	6-40°	6-0.40
S	7-45°	7-0.45

断屑槽型代号 Chip-breaker Code	
NR8	半精加工 Semi-finishing
GM	半精加工 Semi-finishing
CM3	半精加工 Semi-finishing
GM3	快进给 Fast-feed

切削方向 Cutting direction	
R	右 Right
L	左 Left
N	双向 Bi-directionality

普通铣削刀片
General Milling Inserts

RCKT/ RPHT

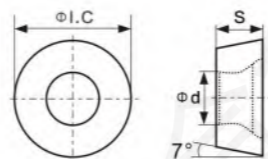

刀片外形 Inserts Shape	型号 Type	基本尺寸 Dimension(mm)			牌号 Grade							
					P		M		K		S	
		$\phi I.C$	S	ϕd	JGA10A	JGA20F	JGA20H	JGM30R	JGK10R	JGS20C	JGS20A	JTN20
	RCKT10T3MO-DS3	10	3.97	4.4								●
	RCKT1204MO-DS3	12	4.76	4.0								●
	RCKT1606MO-BR8	16	6.35	5.5	●	●	○					
	RPHT1204MO-TC	12	4.76	4.5					●	●		

● 主推荐牌号 Main recommended grades ● 一般牌号 General grades ○ 可生产牌号 Available grades

普通铣削刀片
General Milling Inserts

RPMW/ RPMT

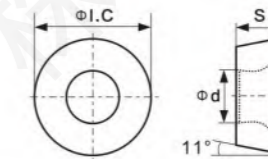

刀片外形 Inserts Shape	型号 Type	基本尺寸 Dimension(mm)			牌号 Grade							
					P		M		K		金陶 Cermet	
		$\phi I.C$	S	ϕd	JGA05A	JGA10A	JGA20F	JGA20H	JGM30R	JGK10R	JTN20	JTN35
	RPMW08T2MOT	8	2.80	3.3	●	●	○					
	RPMW1003MO	10	3.18	4.5	●	●	○					
	RPMW10T3MO	10	3.97	4.6	●	●	○					
	RPMW1204MO	12	4.76	4.4	●	●	○					
	RPMT08T2MOE-SL	8	2.58	3.3	●	●						
	RPMT10T3MOE-SL	10	3.97	4.4	●	●						
	RPMT1204MO-SL	12	4.76	4.3	●	●						
	RPMT1204MO-DL	12	4.76	4.4	●		●					

● 主推荐牌号 Main recommended grades ● 一般牌号 General grades ○ 可生产牌号 Available grades

普通铣削刀片
General Milling Inserts

RDMW/RDMT

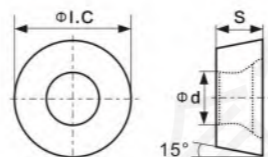

刀片外形 Inserts Shape	型号 Type	基本尺寸 Dimension(mm)			牌号 Grade								
		φI.C	S	φd	P M K						金陶 Cermet		
					JGA05A	JGA10A	JGA20F	JGA20H	JGM30R	JGK10R	JTN20	JTN35	
	RDMW1204MO-NR8	12	4.76	4.4	●	●							
	RDMW1605MO-NR8	16	5.56	5.5	●	●							
	RDMW1204MO	12	4.76	4.4	●	○							
	RDMW1604MO	16	4.76	5.0	●	○							
	RDMW1605MO	16	5.56	5.5	●	○							
	RDMT0802MO-SN	8	2.48	3.4	●	○							
	RDMT10T3MO-SN	10	3.97	4.5	●	○							
	RDMT1204MO-SN	12	4.76	4.4	●	○							

● 主推荐牌号 Main recommended grades ○ 一般牌号 General grades ○ 可生产牌号 Available grades

普通铣削刀片
General Milling Inserts

APMT

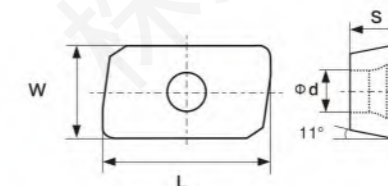

刀片外形 Inserts Shape	型号 Type	基本尺寸 Dimension(mm)					牌号 Grade							
		L	S	W	φd	Re	P M K						金陶 Cermet	
							JGA05A	JGA10A	JGA20F	JGA20H	JGM30R	JGK15R	JTN20	JTN35
	APMT1135PDER-FR	11.32	3.5	6.19	2.85	0.8	●	●				●		
	APMT160408PDER-FR	17.21	4.76	9.29	4.48	0.8	●	●				●		
	APMT1135PDER-HM2	11.22	3.5	6.20	2.8	0.8	●	●				●		
	APMT160408PDER-HM2	17.25	4.76	9.26	4.4	0.8	●	●				●		
	APMT1135PDER-DL	11.28	3.6	6.22	2.8	0.8	●				●			
	APMT160408PDER-DL	17.37	5.33	9.32	4.5	0.8	●				●			

● 主推荐牌号 Main recommended grades ○ 一般牌号 General grades ○ 可生产牌号 Available grades

普通铣削刀片
General Milling Inserts

SEEN/SPKN

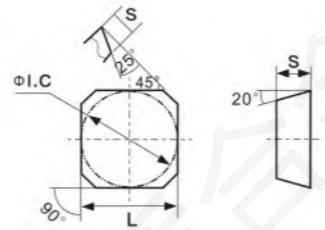

刀片外形 Inserts Shape	型号 Type	基本尺寸 Dimension(mm)			牌号 Grade								
		φI.C	L	S	P			M		K		金陶 Cermet	
					JGA05A	JGA10A	JGA20F	JGA20H	JGM30R	JGK10R	JTN20	JTN35	
	SEEN1203AFTN	12.7	12.7	3.18								●	●
	SEEN1504AFTN	15.875	15.875	4.76								●	●
	SPKN1203ERER	12.7	12.7	3.18			●					●	●
	SPKN1203EDEL	12.7	12.7	3.18			●					●	●

● 主推荐牌号 Main recommended grades ● 一般牌号 General grades ○ 可生产牌号 Available grades

普通铣削刀片
General Milling Inserts

WPGT

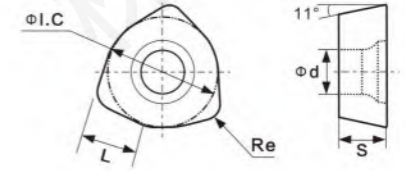

刀片外形 Inserts Shape	型号 Type	基本尺寸 Dimension(mm)					牌号 Grade									
		φI.C	S	L	φd	Re	P			M		K		金陶 Cermet		
							JGA05A	JGA10A	JGA20F	JGA20H	JGM30R	JGK10R	JTN20	JTN35		
	WPGT080615ZSR	12.85	6.35	5.8	5.5	1.5			●		●					

● 主推荐牌号 Main recommended grades ● 一般牌号 General grades ○ 可生产牌号 Available grades

SEET

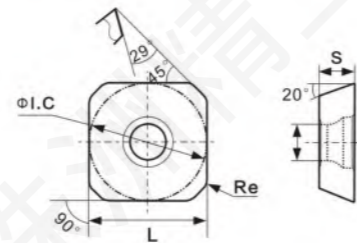

刀片外形 Inserts Shape	型号 Type	基本尺寸 Dimension(mm)					牌号 Grade									
		φI.C	L	S	φd	Re	P			M		K		金陶 Cermet		
							JGA05A	JGA10A	JGA20F	JGA20H	JGM30R	JGK10R	JTN20	JTN35		
	SEET12T3-BS3	13.4	13.4	3.97	4.1	1.532			●							

● 主推荐牌号 Main recommended grades ● 一般牌号 General grades ○ 可生产牌号 Available grades

WDMW

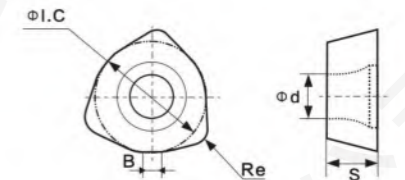

刀片外形 Inserts Shape	型号 Type	基本尺寸 Dimension(mm)				牌号 Grade									
		φI.C	S	B	Re	P			M		K		金陶 Cermet		
						JGA05A	JGA10A	JGA20F	JGA20H	JGM30R	JGK10R	JTN20	JTN35		
	WDMW06T320ZTR	10.00	3.97	1.20	2.00			●		○					
	WDMW080520ZTR	13.00	5.50	1.50	2.00			●		○					
	WDMW10X620ZTR	13.00	6.00	1.20	2.00			●		○					

● 主推荐牌号 Main recommended grades ● 一般牌号 General grades ○ 可生产牌号 Available grades

普通铣削刀片
General Milling Inserts

APKT

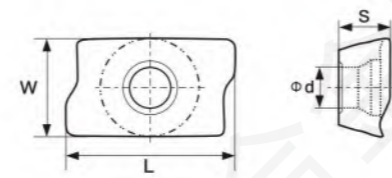

刀片外形 Inserts Shape	型号 Type	基本尺寸 Dimension(mm)				牌号 Grade										
		W	S	L	φd	P			M		K		金陶 Cermet			
						JGA05A	JGA10A	JGA20F	JGA20H	JGM30R	JGK10R	JTN20	JTN35			
	APKT1705PER-TT	10.68	5.56	18.54	4.46		●									

● 主推荐牌号 Main recommended grades ○ 一般牌号 General grades ○ 可生产牌号 Available grades

普通铣削刀片
General Milling Inserts

LNMU/LOGU

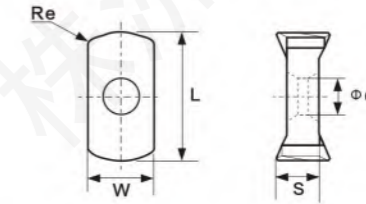

刀片外形 Inserts Shape	型号 Type	基本尺寸 Dimension(mm)					牌号 Grade										
		L	S	W	φd	Re	P			M		K		S		金陶 Cermet	
							JGA10A	JGA20F	JGM30R	JGK10R	JGS20C	JGS20A	JTN20	JTN35			
	LNMU0303ER-GM3	11.9	3.75	6.0	2.85	1.2	●	●	○				●	●			
	LNMU0303ER-GS3	11.9	3.75	6.0	2.85	1.2	●	●	○								
	LOGU030310ER-GM3	12.0	3.96	6.22	3.45	1.0	●	●	○				●	●			

● 主推荐牌号 Main recommended grades ○ 一般牌号 General grades ○ 可生产牌号 Available grades

EPMT/EPNW

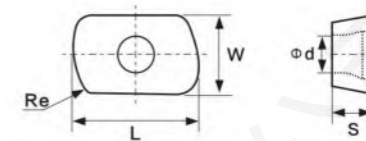

刀片外形 Inserts Shape	型号 Type	基本尺寸 Dimension(mm)					牌号 Grade									
		L	S	W	φd	Re	P			M		K		金陶 Cermet		
							JGA05A	JGA10A	JGA20F	JGA20H	JGM30R	JGK10R	JTN20	JTN35		
	EPMT0603SN-R8	10.00	3.18	6.35	2.8	8.0	○		●	●						
	EPNW0603TN-RL	10.00	3.18	6.35	2.8	8.0	○		●	●						

● 主推荐牌号 Main recommended grades ○ 一般牌号 General grades ○ 可生产牌号 Available grades

普通铣削刀片
General Milling Inserts

XOMX

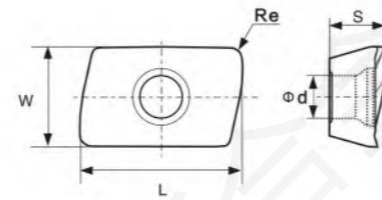

刀片外形 Inserts Shape	型号 Type	基本尺寸 Dimension(mm)					牌号 Grade							
							P			M		K		金陶 Cermet
		L	S	W	φd	Re	JGA05A	JGA10A	JGA20F	JGA20H	JGM30R	JGK10R	JTN20	JTN35
	XOMX10T308TR-M2	10.2	3.85	6.90	2.96	0.80	○	●	●					
	XOMX120408TR-M3	12.7	5.07	8.20	3.85	0.80	○	●	●					
	XOMX120412TR-M1	12.7	5.05	8.20	3.9	1.20	○	●	●					

● 主推荐牌号 Main recommended grades ○ 一般牌号 General grades ○ 可生产牌号 Available grades

普通铣削刀片
General Milling Inserts

JDMT

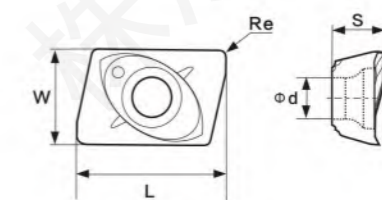

刀片外形 Inserts Shape	型号 Type	基本尺寸 Dimension(mm)					牌号 Grade							
							P			M		K		金陶 Cermet
		L	S	W	φd	Re	JGA05A	JGA10A	JGA20F	JGA20H	JGM30R	JGK10R	JTN20	JTN35
	JDMT070204R-RL	7.1	2.45	4.25	1.9	0.40	●	●	○					
	JDMT070208R-RL	7.1	2.45	4.25	1.9	0.80	●	●	○					

● 主推荐牌号 Main recommended grades ○ 一般牌号 General grades ○ 可生产牌号 Available grades

BLMP

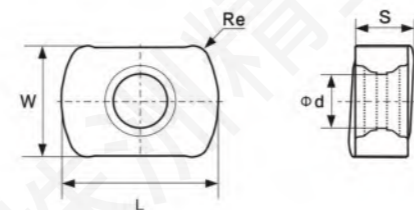

刀片外形 Inserts Shape	型号 Type	基本尺寸 Dimension(mm)					牌号 Grade							
							P			M		K		金陶 Cermet
		L	S	W	φd	Re	JGA05A	JGA10A	JGA20F	JGA20H	JGM30R	JGK10R	JTN20	JTN35
	BLMP0603R-TT	9.0	3.73	6.39	3.1	1.0		●	●	○				
	BLMP0904R-TT	11.95	4.39	9.15	4.1	1.35		●	●	○				

● 主推荐牌号 Main recommended grades ○ 一般牌号 General grades ○ 可生产牌号 Available grades

普通铣削刀片
General Milling Inserts

MPHW

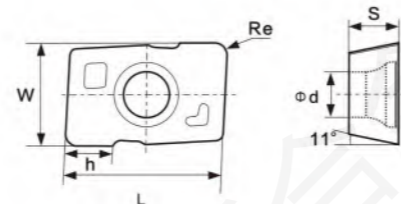

刀片外形 Inserts Shape	型号 Type	基本尺寸 Dimension(mm)					牌号 Grade										
		L	S	W	φd	Re	P			M		K		金陶 Cermet			
							JGA05A	JGA10A	JGA20F	JGA20H	JGM30R	JGK10R	JTN20	JTN35			
	MPHW060308ZEL-RL	10.0	3.18	6.57	2.9	0.8	●	●	○								

● 主推荐牌号 Main recommended grades ● 一般牌号 General grades ○ 可生产牌号 Available grades

普通铣削刀片
General Milling Inserts

SEMT/SEKT

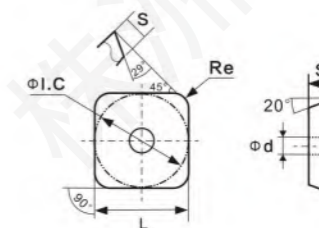

刀片外形 Inserts Shape	型号 Type	基本尺寸 Dimension(mm)					牌号 Grade										
		φI.C	S	L	φd	Re	P			M		K		金陶 Cermet			
							JGA05A	JGA10A	JGA20F	JGA20H	JGM30R	JGK10R	JTN20	JTN35			
	SEMT13T3AGSN-ZY	13.4	3.97	13.4	4.4	1.0		●	●		○						
	SEKT1204AFTN-DR7	12.7	4.76	12.7	5.5	0.8		●	●		○						

● 主推荐牌号 Main recommended grades ● 一般牌号 General grades ○ 可生产牌号 Available grades

SEMR/SEKR

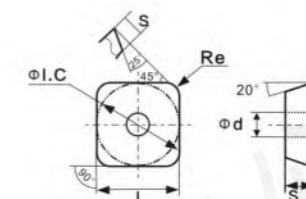

刀片外形 Inserts Shape	型号 Type	基本尺寸 Dimension(mm)					牌号 Grade										
		φI.C	S	L	φd	Re	P			M		K		金陶 Cermet			
							JGA05A	JGA10A	JGA20F	JGA20H	JGM30R	JGK10R	JTN20	JTN35			
	SEMR1203AFTN	12.7	3.18	12.7	2.3	1.6			●		○						
	SEMR1504AFTN	15.875	4.76	15.875	3.2	1.6			●		○						
	SEKR1203AFTN	12.7	3.18	12.7	2.3	1.6			●		○						

● 主推荐牌号 Main recommended grades ● 一般牌号 General grades ○ 可生产牌号 Available grades

快进给铣削刀片 Fast Feeding Milling Inserts

SDMT

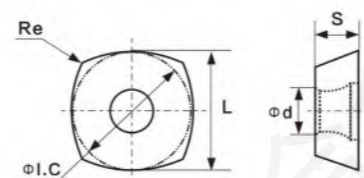

刀片外形 Inserts Shape	型号 Type	基本尺寸 Dimension(mm)					牌号 Grade										
		phi.I.C	S	L	phi.d	Re	P		M		K		S		金陶 Cermet		
							JGA10A	JGA20F	JGM30R	JGA30F	JGK10R	JGS20C	JGS20A	JTN20	JTN35		
	SDMT09T3	12.66	5.54	15.3	4.4	1.2	●	●	○								
	SDMT1204	12.7	4.76	12.7	4.4	1.2	●	●	○								
	SDMT120512-GM3	12.66	5.54	12.66	4.4	1.2	●	●	○	●		●	●				
	SDMT150512-GM3	15.875	5.56	15.875	5.5	1.2	●	●	○	●		●	●				
	SDMT1205ZDTN-RL	12.7	5.54	12.7	4.6	2.8	●	●	○								
	SDMT1505ZDTN-RL	15.875	5.56	15.875	5.5	0.8	●	●	○								

● 主推荐牌号 Main recommended grades ○ 一般牌号 General grades ○ 可生产牌号 Available grades

面铣刀片 Face Milling Inserts

SNMX/SNGX

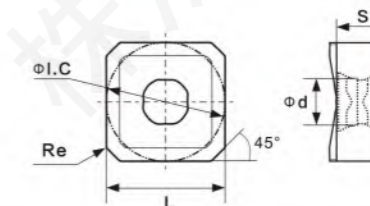

刀片外形 Inserts Shape	型号 Type	基本尺寸 Dimension(mm)					牌号 Grade										
		phi.I.C	S	L	phi.d	Re	P		M		K		金陶 Cermet				
							JGA05A	JGA10A	JGA20F	JGA20H	JGM30R	JGK10R	JTN20	JTN35			
	SNMX1306ENTN-M	13.5	6.8	13.5	5.4	0.4			●		●						
	SNGX1306ANTN-TT	13.5	5.97	13.5	5.4	0.4			●		●						
	SNMX120512-WLT	12.7	5.62	12.7	6.0	1.2			●		●						
	SNMX1205ANN-WLT	12.7	5.51	12.7	6.0	0.8			●		●						

● 主推荐牌号 Main recommended grades ○ 一般牌号 General grades ○ 可生产牌号 Available grades

SOMT

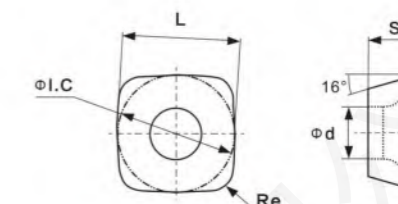

刀片外形 Inserts Shape	型号 Type	基本尺寸 Dimension(mm)					牌号 Grade										
		phi.I.C	S	L	phi.d	Re	P		M		K		S		金陶 Cermet		
							JGA10A	JGA20F	JGM30R	JGA30F	JGK10R	JGS20C	JGS20A	JTN20	JTN35		
	SOMT100420ER-GM3	10.39	4.59	10.39	4.6	2.0	●	●	●	○	●	●					
	SOMT140520ER-GM3	14.16	5.56	14.16	5.8	2.0	●	●	●	○	●	●					

● 主推荐牌号 Main recommended grades ○ 一般牌号 General grades ○ 可生产牌号 Available grades

面铣刀片

Face Milling Inserts

ONMU

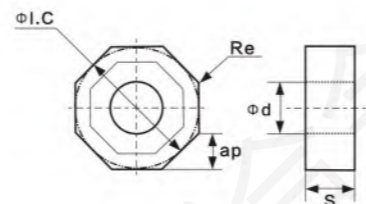

刀片外形 Inserts Shape	型号 Type	基本尺寸 Dimension(mm)					牌号 Grade										
		phi I.C	S	ap	BS	Re	P			M		K		金陶 Cermet			
							JGA05A	JGA10A	JGA20F	JGA20H	JGM30R	JGK10R	JTN20	JTN35			
	ONMU050505-TN	13.0	5.5	3.5	5.0	0.5			●		●						

● 主推荐牌号 Main recommended grades ● 一般牌号 General grades ○ 可生产牌号 Available grades

面铣刀片

Face Milling Inserts

WNMU

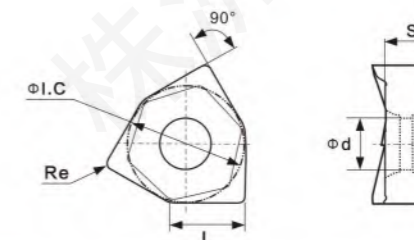

刀片外形 Inserts Shape	型号 Type	基本尺寸 Dimension(mm)					牌号 Grade											
		phi I.C	S	L	phi d	Re	P			M		K		S		金陶 Cermet		
							JGA10A	JGA20F	JGM30R	JGA30F	JGK10R	JGS20C	JGS20A	JTN20	JTN35			
	WNMU080608EN-GM3	14.02	6.55	8.87	6.20	0.8		●	○	●	●	●	●					

● 主推荐牌号 Main recommended grades ● 一般牌号 General grades ○ 可生产牌号 Available grades

PNMU

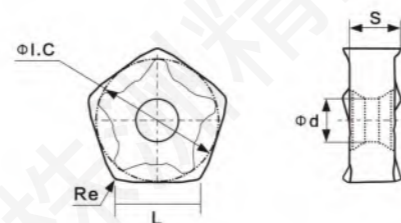

刀片外形 Inserts Shape	型号 Type	基本尺寸 Dimension(mm)					牌号 Grade										
		phi I.C	S	L	phi d	Re	P			M		K		金陶 Cermet			
							JGA05A	JGA10A	JGA20F	JGA20H	JGM30R	JGK10R	JTN20	JTN35			
	PNMU0905XNER-GM3	13.4	6.19	9.3	4.64	0.8		●	●					○			

● 主推荐牌号 Main recommended grades ● 一般牌号 General grades ○ 可生产牌号 Available grades

XNEX

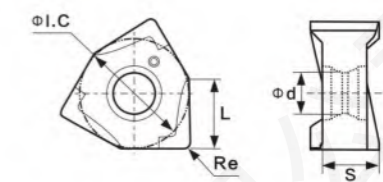



刀片外形 Inserts Shape	型号 Type	基本尺寸 Dimension(mm)					牌号 Grade										
		phi I.C	S	L	phi d	Re	P			M		K		金陶 Cermet			
							JGA05A	JGA10A	JGA20F	JGA20H	JGM30R	JGK10R	JTN20	JTN35			
	XNEX040304TR-EM3	6.71	3.29	4.3	3.1	0.4			●				●				
	XNEX040308TR-EM3	6.71	3.29	4.3	3.1	0.8			●				●				
	XNEX080608TR-NR8	12.48	6.45	8.0	4.65	0.8			●				●				

● 主推荐牌号 Main recommended grades ● 一般牌号 General grades ○ 可生产牌号 Available grades

负型六边形铣削刀片 Negative Heptagonal Milling Inserts

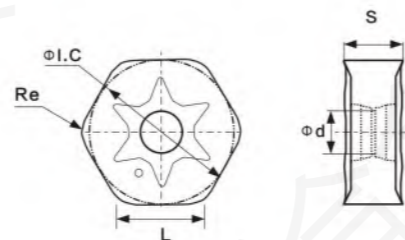
HNGX





刀片外形 Inserts Shape	型号 Type	基本尺寸 Dimension(mm)					牌号 Grade									
		φI.C	S	L	φd	Re	P			M		K		金陶 Cermet		
							JGA05A	JGA10A	JGA20F	JGA20H	JGM30R	JGK10R	JTN20	JTN35		
	HNGX0906ANSN-PLT	16.5	6.35	9.1	4.9	1.0			●		●	●				

● 主推荐牌号 Main recommended grades ● 一般牌号 General grades ○ 可生产牌号 Available grades

玉米铣刀系列 Corn Milling Inserts Series

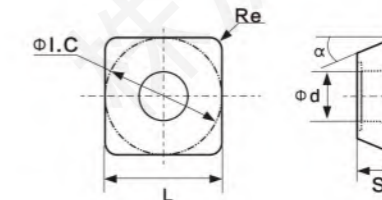
SPMT



刀片外形 Inserts Shape	型号 Type	基本尺寸 Dimension(mm)					牌号 Grade									
		φI.C	S	L	φd	Re	P			M		K		金陶 Cermet		
							JGA05A	JGA10A	JGA20F	JGA20H	JGM30R	JGK10R	JTN20	JTN35		
	SPMT120408	12.70	4.76	12.70	5.5	0.8			●	●	○					
	SPMT120608	12.70	6.35	12.70	5.5	0.6			●	●	○					

● 主推荐牌号 Main recommended grades ● 一般牌号 General grades ○ 可生产牌号 Available grades

铣削刀片加工案例 Application Cases for Milling

案例分析 Case Analysis

- ▶ 被加工材料
Processed material
扎辊底座 / ZG35CrMo
Tie Roller Base / ZG35CrMo
- ▶ 加工方式
Processing methods
方肩铣
Square shoulder milling
- ▶ 使用刀片
Use of inserts
APMT160408PDER-DL/JGA20H
- ▶ 加工参数
Processing parameters
 $f=200\text{mm}/r$, $ap=0.5\text{mm}$
 $Vc=125\text{m}/\text{min}$, $n=160$

▶ 切削性能 Cutting performance

切削性能 Cutting Performance	
精工寿命 Life time of ZZJG inserts	5件/刃 Pieces/edge
国外某品牌 Life time of another brand	6件/刃 Pieces/edge

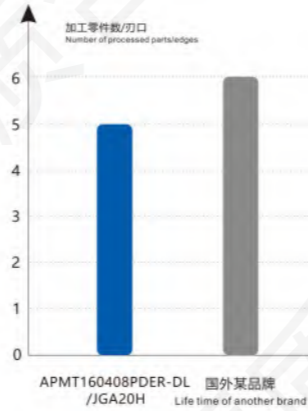

我司品牌产品寿命为国外竞争对手产品的80%以上，性价比优势明显。

The service life of our branded products can be reached to more than 80% of the products from foreign competitors, with obvious cost-effective advantage.

案例分析 Case Analysis

- ▶ 被加工材料
Processed material
模具 / Cr12
Mold / Cr12
- ▶ 加工方式
Processing methods
面铣
Face milling
- ▶ 使用刀片
Use of inserts
SEEN1203AFTN / JTN35
- ▶ 加工参数
Processing parameters
 $f=0.11\text{mm}/r$, $ap=0.5\text{mm}$
 $Vc=155\text{m}/\text{min}$, $n=750$

▶ 切削性能 Cutting performance

切削性能 Cutting Performance	
精工寿命 Life time of ZZJG inserts	25分钟Min
国外某品牌 Life time of another brand	25分钟Min

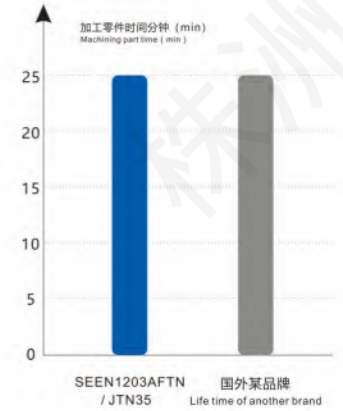

专机模具材料面铣加工，我司产品寿命与竞争对手一致，磨损均匀。

For face milling of specialized mould materials, the life of our products is same as that of our competitors, with uniform wear.

案例分析 Case Analysis

- ▶ 被加工材料
Processed material
发动机钢件 / Ht250
Engine steel parts / Ht250
- ▶ 加工方式
Processing methods
面铣
Face milling
- ▶ 使用刀片
Use of inserts
SNMX1205ANN-F57/JGA20F
- ▶ 加工参数
Processing parameters
 $f=0.12\text{mm}/r$, $ap=3.0\text{mm}$
 $Vc=230\text{m}/\text{min}$

▶ 切削性能 Cutting performance

切削性能 Cutting Performance	
精工寿命 Life time of ZZJG inserts	65件/刃 Pieces/edge
国外某品牌 Life time of another brand	70件/刃 Pieces/edge

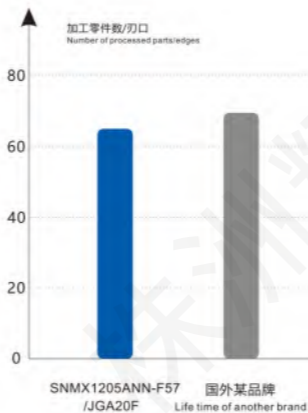

发动机缸体面铣加工45°刀盘，切削轻快。

For face milling of engine cylinders with 45° cutter, cutting easier.

案例分析 Case Analysis

- ▶ 被加工材料
Processed material
曲轴 / 40Cr
Crankshaft / 40Cr
- ▶ 加工方式
Processing methods
曲轴侧铣
Crankshaft side milling
- ▶ 使用刀片
Use of inserts
WNMU080608EN / JGA20F
- ▶ 加工参数
Processing parameters
 $f=0.2\text{mm}/r$, $ap=2.0\text{mm}$
 $Vc=180\text{m}/\text{min}$

▶ 切削性能 Cutting performance

切削性能 Cutting Performance	
精工寿命 Life time of ZZJG inserts	100台/刃 Units/blade
国外某品牌 Life time of another brand	120台/刃 Units/blade

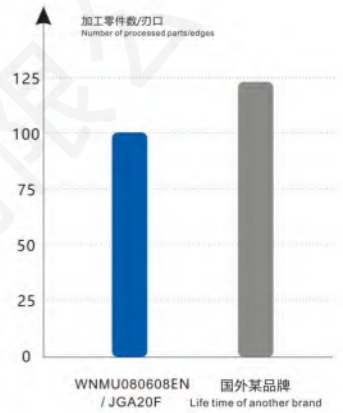

曲轴侧铣加工，进给较快，切削效率高。

For crankshaft side milling, our products feed faster, and has higher cutting efficiency.

铣削加工常见问题及解决方案 Common Problems and Solutions In Milling

常见问题 Main problem	选择条件 Selection condition	刀具材料选择 Selection of Tool material		切削条件 Cutting Condition			改变铣刀直径与宽度 Change diameter and width of milling tools
		硬度更高的材料 Material with higher hardness	韧性好的材料 Material with good toughness	切削速度 Cutting speed	进给 Feeding	切深 Cutting depth	
后刀面磨损 Flank wear	切削条件不合适 Cutting condition is not suitable			↓			
	切削刃几何形状不合适 Cutting edge geometry is not appropriate	✓					
前刀面磨损大 Front edge wear	切削条件不合适 Cutting condition is not suitable			↓	↓	↓	
	切削刃几何形状不合适 Cutting edge geometry is not appropriate	✓					
切削刃破损 Cutting edge wear	切削条件不合适 Cutting condition is not suitable				↓	↓	
	切削刃几何形状不合适 Cutting edge geometry is not appropriate		✓				
热冲击破损 Thermal shock damage	切削条件不合适 Cutting condition is not suitable			↓	↓	↓	
	切削刃几何形状不合适 Cutting edge geometry is not appropriate						
积屑瘤粘结 Built-up Edge Bonding	切削条件不合适 Cutting condition is not suitable			↑	↑		
	切削刃几何形状不合适 Cutting edge geometry is not appropriate						
表面粗糙度大 Surface roughness	刀具磨损铣刀振摆大 Tool wear, milling vibration	✓		↑	↓	↓	
产生毛刺 Burrs	切削条件不合适 Cutting condition is not suitable			↓	↓	↓	✓
	切削刃几何形状不合适 Cutting edge geometry is not appropriate						
产生塌边 Collapse	切削条件不合适 Cutting condition is not suitable				↓	↓	
	切削刃几何形状不合适 Cutting edge geometry is not appropriate						
平面度平行度恶化 Flatness and parallelism deterioration	切削刃几何形状不合适 Cutting edge geometry is not appropriate				↓	↓	
振动大 Vibration	切削条件工艺不合适 Cutting condition is not suitable			↓	↓	↓	✓
其他 Others	切屑缠绕堵塞 Cutting Wound Blocking	切削条件不合适 Cutting condition is not suitable			↑	↑↓	✓
		切削刃几何形状不合适 Cutting condition is not suitable					

切削液 Cutting fluid	前角 Front angle	主偏角 Cutting edge angle	切削刃强度 Cutting edge strength	刀具形状 Shape of tool			机床装夹 Machine tool clamping						
				齿数 Number of teeth	增大容屑空间 Increase chip-hold space	检查副切削刃几何形状 Check geometry of auxiliary cutting edge	检查端面跳动 Checking end-face runout	提高刀具刚性 Improve blade rigidity	工件刀柄装夹 Workpiece holder clamping	刀柄悬伸 Tool holder overhanging	动力、机床间隙 Power machine clearance		
✓													
	↑		↓										
✓													
	↑	↓	↓										
			↑			✓	✓	✓	✓	✓	✓	✓	✓
✓													
	↑		↓										
✓			↓			✓	✓						
	↑	↑	↓			✓							
	↑	↑	↓			✓	✓	✓	✓	✓	✓	✓	✓
	↑	↑	↓				✓	✓	✓	✓	✓	✓	✓
✓							↓						
	↑						↓	✓					

B 铣削刀片
Milling inserts

B 铣削刀片
Milling inserts



P105

P106



P110



P108



P107



P107

孔加工

Hole Machining Inserts

浅孔钻刀片 105
Shallow hole drilling Inserts

深孔钻刀片 107
Deep-hole drilling Inserts

浅孔钻刀片

Shallow hole drilling Inserts

WCMX/WCMT

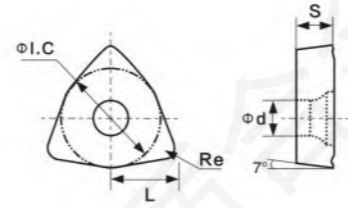

刀片外形 Inserts Shape	型号 Type	基本尺寸 Dimension(mm)					牌号 Grade							
							P			M		K		金陶 Cermet
		phi I.C	S	L	phi d	Re	JGA05A	JGA10A	JGA20F	JGA20H	JGM30R	JGK10R	JTN20	JTN35
	WCMX030208-ZY	5.56	2.38	3.80	2.80	0.8	●		●					
	WCMX040208-ZY	6.35	2.38	4.30	3.10	0.8	●		●					
	WCMT050308-ZY	7.94	3.18	5.50	3.40	0.8	●		●					
	WCMT06T308-ZY	9.525	3.97	6.50	3.80	0.8	●		●					
	WCMT080412-ZY	12.70	4.76	8.70	4.40	1.2	●		●					

● 主推荐牌号 Main recommended grades ● 一般牌号 General grades ○ 可生产牌号 Available grades

浅孔钻刀片

Shallow hole drilling Inserts

SPMG

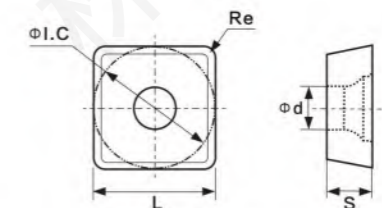

刀片外形 Inserts Shape	型号 Type	基本尺寸 Dimension(mm)				牌号 Grade							
						P			M		K		金陶 Cermet
		phi I.C	S	phi d	Re	JGA05A	JGA10A	JGA20F	JGA20H	JGM30R	JGK10R	JTN20	JTN35
	SPMG050204-TT	5.00	2.38	2.25	0.4	○	●						
	SPMG060204-TT	6.00	2.38	2.61	0.4	○	●						
	SPMG07T308-TT	7.94	3.97	2.85	0.8	○	●						
	SPMG090408-TT	9.80	4.30	4.05	0.8	○	●						
	SPMG110408-TT	11.50	4.80	4.45	0.8	○	●						
	SPMG140512-TT	14.30	5.20	5.75	1.2	○	●						

● 主推荐牌号 Main recommended grades ● 一般牌号 General grades ○ 可生产牌号 Available grades

深孔钻刀片

Deep-hole drilling Inserts

TPMT

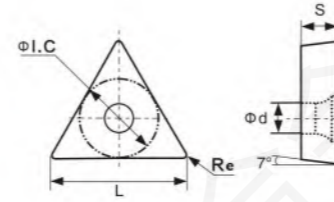

刀片外形 Inserts Shape	型号 Type	基本尺寸 Dimension(mm)					牌号 Grade							
							P			M		K		金陶 Cermet
		phi I.C	S	L	phi d	Re	JGA05A	JGA10A	JGA20F	JGA20H	JGM30R	JGK10R	JTN20	JTN35
	TPMT16T312R-23	9.525	3.97	16.50	3.4	1.2				●	○			
	TPMT220612R-23	12.70	6.35	22.00	4.4	1.2				●	○			

● 主推荐牌号 Main recommended grades ○ 一般牌号 General grades ○ 可生产牌号 Available grades

深孔钻刀片

Deep-hole drilling Inserts

TPMX

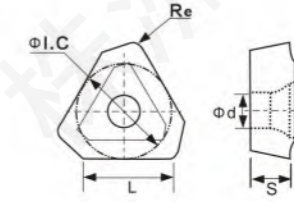

刀片外形 Inserts Shape	型号 Type	基本尺寸 Dimension(mm)					牌号 Grade							
							P			M		K		金陶 Cermet
		phi I.C	S	L	phi d	Re	JGA05A	JGA10A	JGA20F	JGA20H	JGM30R	JGK10R	JTN20	JTN35
	TPMX1403-RG	8.45	3.52	8.30	2.8	0.8			●	○				
	TPMX140308-LG	8.45	3.52	8.30	2.8	0.8			●	○				
	TPMX1704-RG	10.30	4.04	9.60	3.9	0.8			●	○				
	TPMX170408-LG	10.30	4.04	9.60	3.9	0.8			●	○				
	TPMX240512-LG	14.20	5.50	13.90	4.4	1.2			●	○				
	TPMX2405-RG	14.20	5.50	13.90	4.4	1.2			●	○				
	TPMX280716-LG	17.00	7.60	16.10	5.5	1.6			●	○				
	TPMX2807-RG	17.00	7.60	16.10	5.5	1.6			●	○				

● 主推荐牌号 Main recommended grades ○ 一般牌号 General grades ○ 可生产牌号 Available grades

R424.9

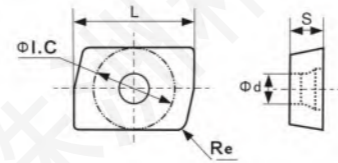

刀片外形 Inserts Shape	型号 Type	基本尺寸 Dimension(mm)					牌号 Grade							
							P			M		K		金陶 Cermet
		phi I.C	L	S	phi d	Re	JGA05A	JGA10A	JGA20F	JGA20H	JGM30R	JGK10R	JTN20	JTN35
	R424.9-13T308-23	10.00	14.60	3.96	3.4	0.8								
	R424.9-180608-23	11.50	20.40	6.35	4.5	0.8				●	○			

● 主推荐牌号 Main recommended grades ○ 一般牌号 General grades ○ 可生产牌号 Available grades

800

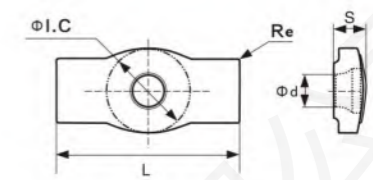

刀片外形 Inserts Shape	型号 Type	基本尺寸 Dimension(mm)					牌号 Grade							
							P			M		K		金陶 Cermet
		phi I.C	L	S	phi d	Re	JGA05A	JGA10A	JGA20F	JGA20H	JGM30	JGK10R	JTN20	JTN35
	800-06A	7.70	17.975	2.99	2.80	0.20				●				
	800-07A	9.20	19.975	3.49	3.50	0.25				●				

● 主推荐牌号 Main recommended grades ○ 一般牌号 General grades ○ 可生产牌号 Available grades

深孔钻刀片

Deep-hole drilling Inserts

800

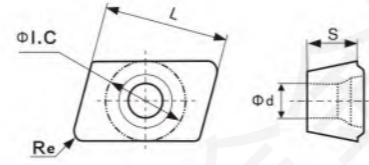

刀片外形 Inserts Shape	型号 Type	基本尺寸 Dimension(mm)					牌号 Grade										
		φI.C	L	S	φd	Re	P			M		K		金陶 Cermet			
							JGA05A	JGA10A	JGA20F	JGA20H	JGM30R	JGK10R	JTN20	JTN35			
	800-08T308H-PG	9.00	8.40	3.97	2.80	0.40					●						
	800-09T308H-PG	9.00	9.62	3.97	2.80	0.40					●						
	800-11T308H-PG	9.00	12.7	3.97	2.80	0.40					●						
	800-050308M-IL	5.55	8.00	3.18	2.50	0.80					●						
	800-06T308M-CL	6.34	9.83	4.00	2.80	0.80					●						
	800-08T308M-CG	9.85	7.94	3.97	2.80	0.80					●						
											●						
	800-08T308M-IG	9.85	7.92	3.97	2.80	0.80					●						
											●						
	800-060308H-PL	6.42	8.00	3.18	2.50	0.25					●						
											●						

● 主推荐牌号 Main recommended grades ● 一般牌号 General grades ○ 可生产牌号 Available grades

深孔钻刀片

Deep-hole drilling Inserts

R800.24

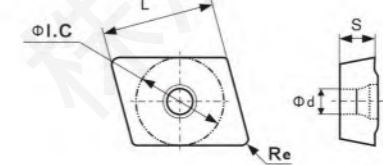

刀片外形 Inserts Shape	型号 Type	基本尺寸 Dimension(mm)					牌号 Grade										
		φI.C	L	S	φd	Re	P			M		K		金陶 Cermet			
							JGA05A	JGA10A	JGA20F	JGA20H	JGM30R	JGK10R	JTN20	JTN35			
	R800.24-06T308M-CG	9.87	6.35	3.97	2.80	0.80					●						
	R800.24-08T308M-CG	9.87	7.94	3.97	2.80	0.80					●						
	R800.24-10T308M-CG	9.87	9.53	3.97	2.80	0.80					●						
	R800.24-12T308M-CG	9.87	12.70	3.97	2.80	0.80					●						

● 主推荐牌号 Main recommended grades ● 一般牌号 General grades ○ 可生产牌号 Available grades

R800.24

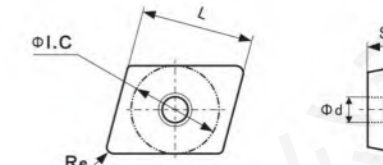

刀片外形 Inserts Shape	型号 Type	基本尺寸 Dimension(mm)					牌号 Grade										
		φI.C	L	S	φd	Re	P			M		K		金陶 Cermet			
							JGA05A	JGA10A	JGA20F	JGA20H	JGM30R	JGK10R	JTN20	JTN35			
	R800.24-06T308M-IG	9.87	6.35	3.97	2.80	0.80					●						
	R800.24-08T308M-IG	9.87	7.94	3.97	2.80	0.80					●						
	R800.24-12T308M-IG	9.87	12.70	3.97	2.80	0.80					●						

● 主推荐牌号 Main recommended grades ● 一般牌号 General grades ○ 可生产牌号 Available grades



通用加工

Universal machining

铣刀系列

Milling cutter series

▶ 通用：平头、球刀、圆鼻刀
General purpose: flat head, ball head, round nose

▶ 铝用
For aluminum

加工中心一站式

Machining Center, One-Stop



整硬刀具

Solid Carbide Cutting Tools

铣刀命名规则 114
Naming Rules for Solid Milling Tools

整体硬质合金铣刀系列 115
Solid Carbide Milling Tool Series

立铣刀常见问题及对策 128
Common Problems and Solutions for End Mill



铣刀命名规则

Naming Rules of Carbide End Mills



整硬刀具
Solid Carbide Cutting Tools

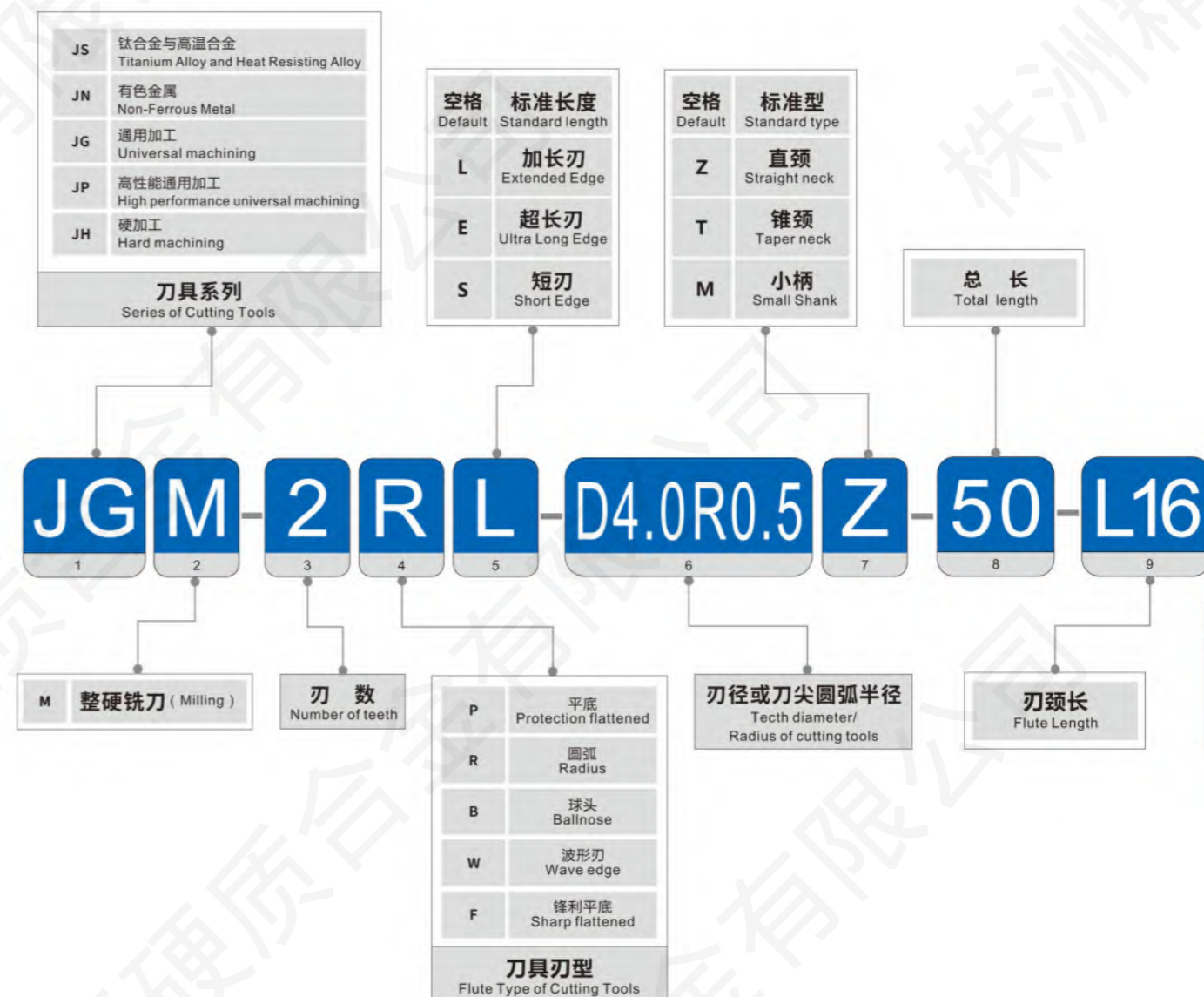

四刃直柄平头立铣刀

Four flutes straight shank square end mills

JGM-4P

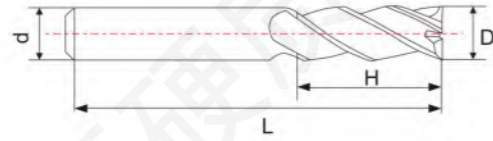

四刃直柄长刃平头立铣刀

Four flutes straight shank long flush end mills

JGM-4PL

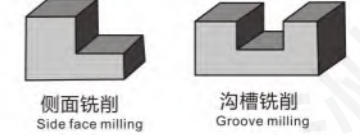
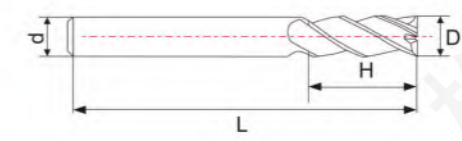

订货号 Specifications	刃径D(mm) Tool Diameter	R角/半径R Angle/ Radius	刃长H(mm) Flute Length	全长L(mm) Overall Length	柄径d(mm) Shank Diameter	刃数 Number of teeth	库存 Stock
JGM-4P-D3.0M-50	3.0	/	8	50	4	4	●
JGM-4P-D3.5M-50	3.5	/	10	50	4	4	●
JGM-4P-D4.0M-50	4.0	/	11	50	4	4	●
JGM-4P-D3.0-50	3.0	/	8	50	6	4	●
JGM-4P-D3.5-50	3.5	/	10	50	6	4	●
JGM-4P-D4.0-50	4.0	/	11	50	6	4	●
JGM-4P-D4.5-50	4.5	/	11	50	6	4	●
JGM-4P-D5.0-50	5.0	/	13	50	6	4	●
JGM-4P-D5.5-50	5.5	/	16	50	6	4	●
JGM-4P-D6.0-50	6.0	/	16	50	6	4	●
JGM-4P-D7.0-60	7.0	/	20	60	8	4	●
JGM-4P-D8.0-60	8.0	/	20	60	8	4	●
JGM-4P-D10.0-75	10.0	/	25	75	10	4	●
JGM-4P-D12.0-75	12.0	/	30	75	12	4	●
JGM-4P-D14.0-75	14.0	/	32	75	14	4	●
JGM-4P-D16.0-100	16.0	/	45	100	16	4	●
JGM-4P-D18.0-100	18.0	/	45	100	18	4	●
JGM-4P-D20.0-100	20.0	/	45	100	20	4	●

● 常备库存 Standing stock ○ 按订单生产 Make to order

订货号 Specifications	刃径D(mm) Tool Diameter	R角/半径R Angle/ Radius	刃长H(mm) Flute Length	全长L(mm) Overall Length	柄径d(mm) Shank Diameter	刃数 Number of teeth	库存 Stock
JGM-4PL-D3.0M-75	3.0	/	12	75	4	4	●
JGM-4PL-D4.0M-75	4.0	/	15	75	4	4	●
JGM-4PL-D3.0-75	3.0	/	12	75	6	4	●
JGM-4PL-D4.0-75	4.0	/	15	75	6	4	●
JGM-4PL-D5.0-75	5.0	/	20	75	6	4	●
JGM-4PL-D6.0-75	6.0	/	20	75	6	4	●
JGM-4PL-D8.0-100	8.0	/	25	100	8	4	●
JGM-4PL-D10.0-100	10.0	/	30	100	10	4	●
JGM-4PL-D12.0-100	12.0	/	35	100	12	4	●
JGM-4PL-D14.0-100	14.0	/	40	100	14	4	●
JGM-4PL-D16.0-150	16.0	/	50	150	16	4	●
JGM-4PL-D20.0-150	20.0	/	50	150	20	4	●

● 常备库存 Standing stock ○ 按订单生产 Make to order

被加工材料适用表 (■ 非常适合 □ 适合)

Applicable Table of Processed Materials (■ Perfect Suitable □ Suitable)

被加工材料 Processed Material											
碳素钢 Carbon steel	合金钢 Alloy steel	预硬钢、淬硬钢 Pre-hardened steel, Hardened steel				不锈钢 Stainless steel	铸铁 cast iron 球墨铸铁 ductile iron	铜合金 Copper Alloy	铝合金 Aluminum Alloy	钛合金 Titanium Alloy	耐热合金 Heat-resisting Alloy
		~40HRC	~50HRC	~55HRC	~68HRC						
■	■	■	□		□	■					

被加工材料适用表 (■ 非常适合 □ 适合)

Applicable Table of Processed Materials (■ Perfect Suitable □ Suitable)

被加工材料 Processed Material											
碳素钢 Carbon steel	合金钢 Alloy steel	预硬钢、淬硬钢 Pre-hardened steel, Hardened steel				不锈钢 Stainless steel	铸铁 cast iron 球墨铸铁 ductile iron	铜合金 Copper Alloy	铝合金 Aluminum Alloy	钛合金 Titanium Alloy	耐热合金 Heat-resisting Alloy
		~40HRC	~50HRC	~55HRC	~68HRC						
■	■	■	□	■	□	■					

四刃直柄圆弧立铣刀

Four flutes straight shank round end mills

JGM-4R

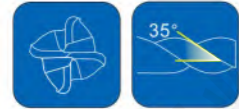
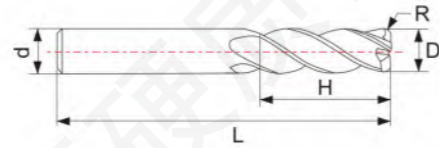

二刃直柄球头立铣刀

Two flutes straight shank ball end mills

JGM-2B

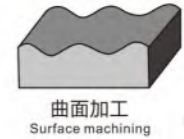
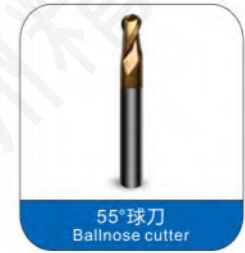
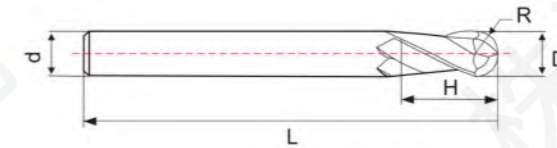

订货号 Specifications	刃径D(mm) Tool Diameter	R角/半径R Angle/ Radius	刃长H(mm) Flute Length	全长L(mm) Overall Length	柄径d(mm) Shank Diameter	刃数 Number of teeth	库存 Stock
JGM-4R-D3.0R0.2M-50	3.0	0.2	8	50	4	4	●
JGM-4R-D4.0R0.3M-50	4.0	0.3	10	50	4	4	●
JGM-4R-D4.0R0.5M-50	4.0	0.5	10	50	4	4	●
JGM-4R-D3.0R0.2-50	3.0	0.2	8	50	6	4	●
JGM-4R-D4.0R0.3-50	4.0	0.3	10	50	6	4	●
JGM-4R-D4.0R0.5-50	4.0	0.5	10	50	6	4	●
JGM-4R-D5.0R0.5-50	5.0	0.5	13	50	6	4	●
JGM-4R-D5.0R1.0-50	5.0	1.0	13	50	6	4	●
JGM-4R-D6.0R0.5-50	6.0	0.5	16	50	6	4	●
JGM-4R-D6.0R1.0-50	6.0	1.0	16	50	6	4	●
JGM-4R-D8.0R0.5-60	8.0	0.5	20	60	8	4	●
JGM-4R-D8.0R1.0-60	8.0	1.0	20	60	8	4	●
JGM-4R-D10.0R0.5-75	10.0	0.5	25	75	10	4	●
JGM-4R-D10.0R1.0-75	10.0	1.0	25	75	10	4	●
JGM-4R-D10.0R2.0-75	10.0	2.0	25	75	10	4	●
JGM-4R-D10.0R3.0-75	10.0	3.0	25	75	10	4	●
JGM-4R-D12.0R0.5-75	12.0	0.5	30	75	12	4	●
JGM-4R-D12.0R1.0-75	12.0	1.0	30	75	12	4	●
JGM-4R-D12.0R2.0-75	12.0	2.0	30	75	12	4	●
JGM-4R-D12.0R3.0-75	12.0	3.0	30	75	12	4	●

● 常备库存 Standing stock ○ 按订单生产 Make to order

被加工材料适用表 (■ 非常适合 □ 适合)

Applicable Table of Processed Materials (■ Perfect Suitable □ Suitable)

被加工材料 Processed Material											
碳素钢 Carbon steel	合金钢 Alloy steel	预硬钢、淬硬钢 Pre-hardened steel, Hardened steel				不锈钢 Stainless steel	铸铁 cast iron 球墨铸铁 ductile iron	铜合金 Copper Alloy	铝合金 Aluminum Alloy	钛合金 Titanium Alloy	耐热合金 Heat-resisting Alloy
		~40HRC	~50HRC	~55HRC	~68HRC						
■	■	■	□		□	■					

订货号 Specifications	刃径D(mm) Tool Diameter	R角/半径R Angle/ Radius	刃长H(mm) Flute Length	全长L(mm) Overall Length	柄径d(mm) Shank Diameter	刃数 Number of teeth	库存 Stock
JGM-2B-R1.5M-50	3.0	1.5	6	50	4	2	●
JGM-2B-R1.75M-50	3.5	1.75	8	50	4	2	●
JGM-2B-R2.0M-50	4.0	2.0	8	50	4	2	●
JGM-2B-R1.5-50	3.0	1.5	6	50	6	2	●
JGM-2B-R1.75-50	3.5	1.75	8	50	6	2	●
JGM-2B-R2.0-50	4.0	2.0	8	50	6	2	●
JGM-2B-R2.5-50	5.0	2.5	10	50	6	2	●
JGM-2B-R2.75-50	5.5	2.75	12	50	6	2	●
JGM-2B-R3.0-50	6.0	3.0	12	50	6	2	●
JGM-2B-R3.5-60	7.0	3.5	14	60	8	2	●
JGM-2B-R4.0-60	8.0	4.0	16	60	8	2	●
JGM-2B-R4.5-75	9.0	4.5	18	75	10	2	●
JGM-2B-R5.0-75	10.0	5.0	20	75	10	2	●
JGM-2B-R6.0-75	12.0	6.0	24	75	12	2	●
JGM-2B-R7.0-75	14.0	7.0	28	75	14	2	●
JGM-2B-R8.0-100	16.0	8.0	32	100	16	2	●
JGM-2B-R10.0-100	20.0	10.0	40	100	20	2	●

● 常备库存 Standing stock ○ 按订单生产 Make to order

被加工材料适用表 (■ 非常适合 □ 适合)

Applicable Table of Processed Materials (■ Perfect Suitable □ Suitable)

被加工材料 Processed Material											
碳素钢 Carbon steel	合金钢 Alloy steel	预硬钢、淬硬钢 Pre-hardened steel, Hardened steel				不锈钢 Stainless steel	铸铁 cast iron 球墨铸铁 ductile iron	铜合金 Copper Alloy	铝合金 Aluminum Alloy	钛合金 Titanium Alloy	耐热合金 Heat-resisting Alloy
		~40HRC	~50HRC	~55HRC	~68HRC						
■	■	■	□		□	■					

高性能四刃平头立铣刀

Four flutes straight shank square end mills

JPM-4P

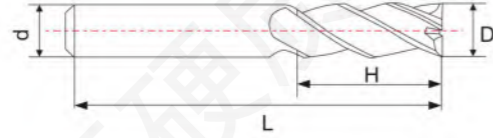

订货号 Specifications	刃径D(mm) Tool Diameter	R角/半径R Angle/ Radius	刃长H(mm) Flute Length	全长L(mm) Overall Length	柄径d(mm) Shank Diameter	刃数 Number of teeth	库存 Stock
JPM-4P-D3.0M-50	3.0	/	8	50	4	4	●
JPM-4P-D3.5M-50	3.5	/	10	50	4	4	●
JPM-4P-D4.0M-50	4.0	/	11	50	4	4	●
JPM-4P-D3.0-50	3.0	/	8	50	6	4	●
JPM-4P-D3.5-50	3.5	/	10	50	6	4	●
JPM-4P-D4.0-50	4.0	/	11	50	6	4	●
JPM-4P-D4.5-50	4.5	/	11	50	6	4	●
JPM-4P-D5.0-50	5.0	/	13	50	6	4	●
JPM-4P-D5.5-50	5.5	/	16	50	6	4	●
JPM-4P-D6.0-50	6.0	/	16	50	6	4	●
JPM-4P-D7.0-60	7.0	/	20	60	8	4	●
JPM-4P-D8.0-60	8.0	/	20	60	8	4	●
JPM-4P-D10.0-75	10.0	/	25	75	10	4	●
JPM-4P-D12.0-75	12.0	/	30	75	12	4	●
JPM-4P-D14.0-75	14.0	/	32	75	14	4	●
JPM-4P-D16.0-100	16.0	/	45	100	16	4	●
JPM-4P-D18.0-100	18.0	/	45	100	18	4	●
JPM-4P-D20.0-100	20.0	/	45	100	20	4	●

● 常备库存 Standing stock ○ 按订单生产 Make to order

高性能四刃加长平头立铣刀

Four flutes straight shank long flush end mills

JPM-4PL

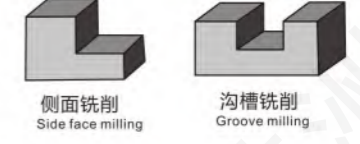
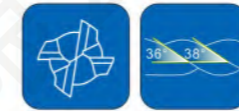
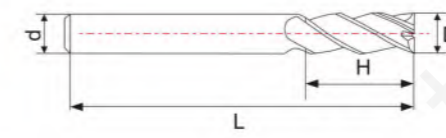

订货号 Specifications	刃径D(mm) Tool Diameter	R角/半径R Angle/ Radius	刃长H(mm) Flute Length	全长L(mm) Overall Length	柄径d(mm) Shank Diameter	刃数 Number of teeth	库存 Stock
JPM-4PL-D3.0M-75	3.0	/	8	75	4	4	●
JPM-4PL-D4.0M-75	4.0	/	11	75	4	4	●
JPM-4PL-D3.0-75	3.0	/	8	75	6	4	●
JPM-4PL-D4.0-75	4.0	/	11	75	6	4	●
JPM-4PL-D5.0-75	5.0	/	13	75	6	4	●
JPM-4PL-D6.0-75	6.0	/	16	75	6	4	●
JPM-4PL-D8.0-100	8.0	/	20	75	8	4	●
JPM-4PL-D10.0-100	10.0	/	25	100	10	4	●
JPM-4PL-D12.0-100	12.0	/	30	100	12	4	●
JPM-4PL-D14.0-100	14.0	/	32	100	14	4	●
JPM-4PL-D16.0-150	16.0	/	45	150	16	4	●
JPM-4PL-D20.0-150	20.0	/	45	150	20	4	●

● 常备库存 Standing stock ○ 按订单生产 Make to order

被加工材料适用表 (■ 非常适合 □ 适合)

Applicable Table of Processed Materials (■ Perfect Suitable □ Suitable)

被加工材料 Processed Material											
碳素钢 Carbon steel	合金钢 Alloy steel	预硬钢、淬硬钢 Pre-hardened steel, Hardened steel				不锈钢 Stainless steel	铸铁 cast iron 球墨铸铁 ductile iron	铜合金 Copper Alloy	铝合金 Aluminum Alloy	钛合金 Titanium Alloy	耐热合金 Heat-resisting Alloy
		~40HRC	~50HRC	~55HRC	~68HRC						
■	■		□	■		□	■				

被加工材料适用表 (■ 非常适合 □ 适合)

Applicable Table of Processed Materials (■ Perfect Suitable □ Suitable)

被加工材料 Processed Material											
碳素钢 Carbon steel	合金钢 Alloy steel	预硬钢、淬硬钢 Pre-hardened steel, Hardened steel				不锈钢 Stainless steel	铸铁 cast iron 球墨铸铁 ductile iron	铜合金 Copper Alloy	铝合金 Aluminum Alloy	钛合金 Titanium Alloy	耐热合金 Heat-resisting Alloy
		~40HRC	~50HRC	~55HRC	~68HRC						
■	■	■	□	■		□	■				

高性能四刃圆弧立铣刀

Four flutes straight shank round end mills

JPM-4R

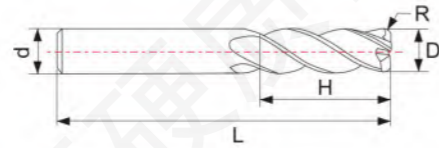

高性能二刃球头立铣刀

Two flutes straight shank ball end mills

JPM-2B

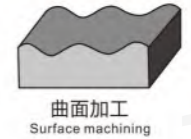
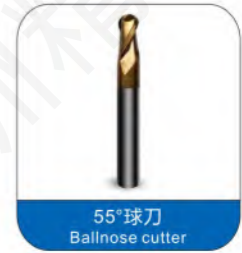
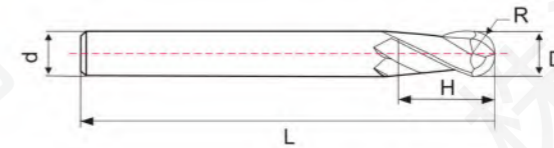

订货号 Specifications	刃径D(mm) Tool Diameter	R角/半径R Angle/ Radius	刃长H(mm) Flute Length	全长L(mm) Overall Length	柄径d(mm) Shank Diameter	刃数 Number of teeth	库存 Stock
JPM-4R-D3.0R0.2M-50	3.0	0.2	8	50	4	4	●
JPM-4R-D4.0R0.3M-50	4.0	0.3	11	50	4	4	●
JPM-4R-D4.0R0.5M-50	4.0	0.5	11	50	4	4	●
JPM-4R-D3.0R0.2-50	3.0	0.2	8	50	6	4	●
JPM-4R-D4.0R0.3-50	4.0	0.3	11	50	6	4	●
JPM-4R-D4.0R0.5-50	4.0	0.5	11	50	6	4	●
JPM-4R-D5.0R0.5-50	5.0	0.5	13	50	6	4	●
JPM-4R-D5.0R1.0-50	5.0	1.0	13	50	6	4	●
JPM-4R-D6.0R0.5-50	6.0	0.5	16	50	6	4	●
JPM-4R-D6.0R1.0-50	6.0	1.0	16	50	6	4	●
JPM-4R-D8.0R0.5-60	8.0	0.5	20	60	8	4	●
JPM-4R-D8.0R1.0-60	8.0	1.0	20	60	8	4	●
JPM-4R-D10.0R0.5-75	10.0	0.5	25	75	10	4	●
JPM-4R-D10.0R1.0-75	10.0	1.0	25	75	10	4	●
JPM-4R-D10.0R2.0-75	10.0	2.0	25	75	10	4	●
JPM-4R-D10.0R3.0-75	10.0	3.0	25	75	10	4	●
JPM-4R-D12.0R0.5-75	12.0	0.5	30	75	12	4	●
JPM-4R-D12.0R1.0-75	12.0	1.0	30	75	12	4	●
JPM-4R-D12.0R2.0-75	12.0	2.0	30	75	12	4	●
JPM-4R-D12.0R3.0-75	12.0	3.0	30	75	12	4	●

● 常备库存 Standing stock ○ 按订单生产 Make to order

订货号 Specifications	刃径D(mm) Tool Diameter	R角/半径R Angle/ Radius	刃长H(mm) Flute Length	全长L(mm) Overall Length	柄径d(mm) Shank Diameter	刃数 Number of teeth	库存 Stock
JPM-2B-R1.5M-50	3.0	1.5	6	50	4	2	●
JPM-2B-R1.75M-50	3.5	1.75	8	50	4	2	●
JPM-2B-R2.0M-50	4.0	2.0	8	50	4	2	●
JPM-2B-R1.5-50	3.0	1.5	6	50	6	2	●
JPM-2B-R1.75-50	3.5	1.75	8	50	6	2	●
JPM-2B-R2.0-50	4.0	2.0	8	50	6	2	●
JPM-2B-R2.5-50	5.0	2.5	10	50	6	2	●
JPM-2B-R2.75-50	5.5	2.75	12	50	6	2	●
JPM-2B-R3.0-50	6.0	3.0	12	50	6	2	●
JPM-2B-R3.5-60	7.0	3.5	14	60	8	2	●
JPM-2B-R4.0-60	8.0	4.0	16	60	8	2	●
JPM-2B-R4.5-75	9.0	4.5	18	75	10	2	●
JPM-2B-R5.0-75	10.0	5.0	20	75	10	2	●
JPM-2B-R6.0-75	12.0	6.0	24	75	12	2	●
JPM-2B-R7.0-75	14.0	7.0	28	75	14	2	●
JPM-2B-R8.0-100	16.0	8.0	32	100	16	2	●
JPM-2B-R10.0-100	20.0	10.0	40	100	20	2	●

● 常备库存 Standing stock ○ 按订单生产 Make to order

被加工材料适用表 (■ 非常适合 □ 适合)

Applicable Table of Processed Materials (■ Perfect Suitable □ Suitable)

被加工材料 Processed Material											
碳素钢 Carbon steel	合金钢 Alloy steel	预硬钢、淬硬钢 Pre-hardened steel, Hardened steel				不锈钢 Stainless steel	铸铁 cast iron 球墨铸铁 ductile iron	铜合金 Copper Alloy	铝合金 Aluminum Alloy	钛合金 Titanium Alloy	耐热合金 Heat-resisting Alloy
		~40HRC	~50HRC	~55HRC	~68HRC						
■	■	□	□	■	□	■					

被加工材料适用表 (■ 非常适合 □ 适合)

Applicable Table of Processed Materials (■ Perfect Suitable □ Suitable)

被加工材料 Processed Material											
碳素钢 Carbon steel	合金钢 Alloy steel	预硬钢、淬硬钢 Pre-hardened steel, Hardened steel				不锈钢 Stainless steel	铸铁 cast iron 球墨铸铁 ductile iron	铜合金 Copper Alloy	铝合金 Aluminum Alloy	钛合金 Titanium Alloy	耐热合金 Heat-resisting Alloy
		~40HRC	~50HRC	~55HRC	~68HRC						
■	■	□	□	■	□	■					

高硬四刃平头立铣刀

Four flutes straight shank square end mills

JHM-4P

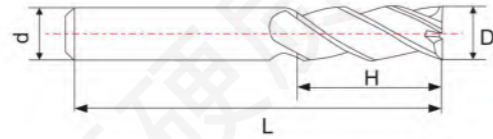

高硬四刃加长平头立铣刀

Four flutes straight shank long flush end mills

JHM-4PL

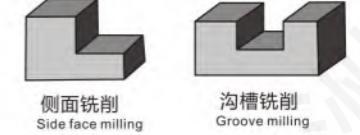
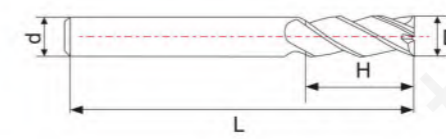

订货号 Specifications	刃径D(mm) Tool Diameter	R角/半径R Angle/ Radius	刃长H(mm) Flute Length	全长L(mm) Overall Length	柄径d(mm) Shank Diameter	刃数 Number of teeth	库存 Stock
JHM-4P-D3.0M-50	3.0	/	8	50	4	4	●
JHM-4P-D3.5M-50	3.5	/	10	50	4	4	●
JHM-4P-D4.0M-50	4.0	/	11	50	4	4	●
JHM-4P-D3.0-50	3.0	/	8	50	6	4	●
JHM-4P-D3.5-50	3.5	/	10	50	6	4	●
JHM-4P-D4.0-50	4.0	/	11	50	6	4	●
JHM-4P-D4.5-50	4.5	/	11	50	6	4	●
JHM-4P-D5.0-50	5.0	/	13	50	6	4	●
JHM-4P-D5.5-50	5.5	/	16	50	6	4	●
JHM-4P-D6.0-50	6.0	/	16	50	6	4	●
JHM-4P-D7.0-60	7.0	/	20	60	8	4	●
JHM-4P-D8.0-60	8.0	/	20	60	8	4	●
JHM-4P-D10.0-75	10.0	/	25	75	10	4	●
JHM-4P-D12.0-75	12.0	/	30	75	12	4	●
JHM-4P-D14.0-75	14.0	/	32	75	14	4	●
JHM-4P-D16.0-100	16.0	/	45	100	16	4	●
JHM-4P-D18.0-100	18.0	/	45	100	18	4	●
JHM-4P-D20.0-100	20.0	/	45	100	20	4	●

● 常备库存 Standing stock ○ 按订单生产 Make to order

订货号 Specifications	刃径D(mm) Tool Diameter	R角/半径R Angle/ Radius	刃长H(mm) Flute Length	全长L(mm) Overall Length	柄径d(mm) Shank Diameter	刃数 Number of teeth	库存 Stock
JHM-4PL-D3.0M-75	3.0	/	12	75	4	4	●
JHM-4PL-D4.0M-75	4.0	/	15	75	4	4	●
JHM-4PL-D3.0-75	3.0	/	12	75	6	4	●
JHM-4PL-D4.0-75	4.0	/	15	75	6	4	●
JHM-4PL-D5.0-75	5.0	/	20	75	6	4	●
JHM-4PL-D6.0-75	6.0	/	20	75	6	4	●
JHM-4PL-D8.0-100	8.0	/	25	100	8	4	●
JHM-4PL-D10.0-100	10.0	/	30	100	10	4	●
JHM-4PL-D12.0-100	12.0	/	35	100	12	4	●
JHM-4PL-D14.0-100	14.0	/	40	100	14	4	●
JHM-4PL-D16.0-150	16.0	/	50	150	16	4	●
JHM-4PL-D20.0-150	20.0	/	55	150	20	4	●

● 常备库存 Standing stock ○ 按订单生产 Make to order

被加工材料适用表 (■ 非常适合 □ 适合)

Applicable Table of Processed Materials (■ Perfect Suitable □ Suitable)

被加工材料 Processed Material											
碳素钢 Carbon steel	合金钢 Alloy steel	预硬钢、淬硬钢 Pre-hardened steel, Hardened steel				不锈钢 Stainless steel	铸铁 cast iron 球墨铸铁 ductile iron	铜合金 Copper Alloy	铝合金 Aluminum Alloy	钛合金 Titanium Alloy	耐热合金 Heat-resisting Alloy
		~40HRC	~50HRC	~55HRC	~68HRC						
■	■	■	■	□	□	■					

被加工材料适用表 (■ 非常适合 □ 适合)

Applicable Table of Processed Materials (■ Perfect Suitable □ Suitable)

被加工材料 Processed Material											
碳素钢 Carbon steel	合金钢 Alloy steel	预硬钢、淬硬钢 Pre-hardened steel, Hardened steel				不锈钢 Stainless steel	铸铁 cast iron 球墨铸铁 ductile iron	铜合金 Copper Alloy	铝合金 Aluminum Alloy	钛合金 Titanium Alloy	耐热合金 Heat-resisting Alloy
		~40HRC	~50HRC	~55HRC	~68HRC						
■	■	■	■	□	□	■					

高硬四刃圆弧立铣刀

Four flutes straight shank round end mills

JHM-4R

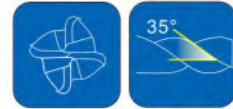
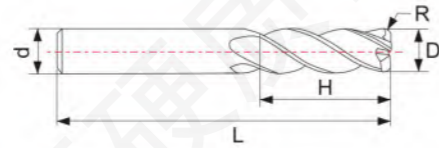

高硬二刃球头立铣刀

Two flutes straight shank ball end mills

JHM-2B

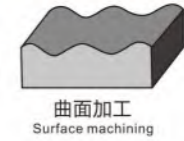
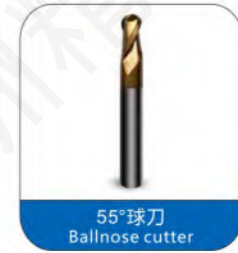
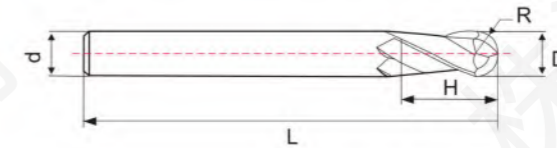

订货号 Specifications	刃径D(mm) Tool Diameter	R角/半径R Angle/ Radius	刃长H(mm) Flute Length	全长L(mm) Overall Length	柄径d(mm) Shank Diameter	刃数 Number of teeth	库存 Stock
JHM-4R-D3.0R0.2M-50	3.0	0.2	8	50	4	4	●
JHM-4R-D4.0R0.3M-50	4.0	0.3	10	50	4	4	●
JHM-4R-D4.0R0.5M-50	4.0	0.5	10	50	4	4	●
JHM-4R-D3.0R0.2-50	3.0	0.2	8	50	6	4	●
JHM-4R-D4.0R0.3-50	4.0	0.3	10	50	6	4	●
JHM-4R-D4.0R0.5-50	4.0	0.5	10	50	6	4	●
JHM-4R-D5.0R0.5-50	5.0	0.5	13	50	6	4	●
JHM-4R-D5.0R1.0-50	5.0	1.0	13	50	6	4	●
JHM-4R-D6.0R0.5-50	6.0	0.5	16	50	6	4	●
JHM-4R-D6.0R1.0-50	6.0	1.0	16	50	6	4	●
JHM-4R-D8.0R0.5-60	8.0	0.5	20	60	8	4	●
JHM-4R-D8.0R1.0-60	8.0	1.0	20	60	8	4	●
JHM-4R-D10.0R0.5-75	10.0	0.5	25	75	10	4	●
JHM-4R-D10.0R1.0-75	10.0	1.0	25	75	10	4	●
JHM-4R-D10.0R2.0-75	10.0	2.0	25	75	10	4	●
JHM-4R-D10.0R3.0-75	10.0	3.0	25	75	10	4	●
JHM-4R-D12.0R0.5-75	12.0	0.5	30	75	12	4	●
JHM-4R-D12.0R1.0-75	12.0	1.0	30	75	12	4	●
JHM-4R-D12.0R2.0-75	12.0	2.0	30	75	12	4	●
JHM-4R-D12.0R3.0-75	12.0	3.0	30	75	12	4	●

● 常备库存 Standing stock ○ 按订单生产 Make to order

被加工材料适用表 (■ 非常适合 □ 适合)

Applicable Table of Processed Materials (■ Perfect Suitable □ Suitable)

被加工材料 Processed Material											
碳素钢 Carbon steel	合金钢 Alloy steel	预硬钢、淬硬钢 Pre-hardened steel, Hardened steel				不锈钢 Stainless steel	铸铁 cast iron 球墨铸铁 ductile iron	铜合金 Copper Alloy	铝合金 Aluminum Alloy	钛合金 Titanium Alloy	耐热合金 Heat-resisting Alloy
		~40HRC	~50HRC	~55HRC	~68HRC						
■	■	■	■	□	□	■					

订货号 Specifications	刃径D(mm) Tool Diameter	R角/半径R Angle/ Radius	刃长H(mm) Flute Length	全长L(mm) Overall Length	柄径d(mm) Shank Diameter	刃数 Number of teeth	库存 Stock
JHM-2B-R1.5M-50	3.0	1.5	6	50	4	2	●
JHM-2B-R1.75M-50	3.5	1.75	8	50	4	2	●
JHM-2B-R2.0M-50	4.0	2.0	8	50	4	2	●
JHM-2B-R1.5-50	3.0	1.5	6	50	6	2	●
JHM-2B-R1.75-50	3.5	1.75	8	50	6	2	●
JHM-2B-R2.0-50	4.0	2.0	8	50	6	2	●
JHM-2B-R2.5-50	5.0	2.5	10	50	6	2	●
JHM-2B-R2.75-50	5.5	2.75	12	50	6	2	●
JHM-2B-R3.0-50	6.0	3.0	12	50	6	2	●
JHM-2B-R3.5-60	7.0	3.5	14	60	8	2	●
JHM-2B-R4.0-60	8.0	4.0	16	60	8	2	●
JHM-2B-R4.5-75	9.0	4.5	18	75	10	2	●
JHM-2B-R5.0-75	10.0	5.0	20	75	10	2	●
JHM-2B-R6.0-75	12.0	6.0	24	75	12	2	●
JHM-2B-R7.0-75	14.0	7.0	28	75	14	2	●
JHM-2B-R8.0-100	16.0	8.0	32	100	16	2	●
JHM-2B-R10.0-100	20.0	10.0	40	100	20	2	●

● 常备库存 Standing stock ○ 按订单生产 Make to order

被加工材料适用表 (■ 非常适合 □ 适合)

Applicable Table of Processed Materials (■ Perfect Suitable □ Suitable)

被加工材料 Processed Material											
碳素钢 Carbon steel	合金钢 Alloy steel	预硬钢、淬硬钢 Pre-hardened steel, Hardened steel				不锈钢 Stainless steel	铸铁 cast iron 球墨铸铁 ductile iron	铜合金 Copper Alloy	铝合金 Aluminum Alloy	钛合金 Titanium Alloy	耐热合金 Heat-resisting Alloy
		~40HRC	~50HRC	~55HRC	~68HRC						
■	■	■	■	□	□	■					

铝加工立铣刀

End mills for aluminum

JNM-3P

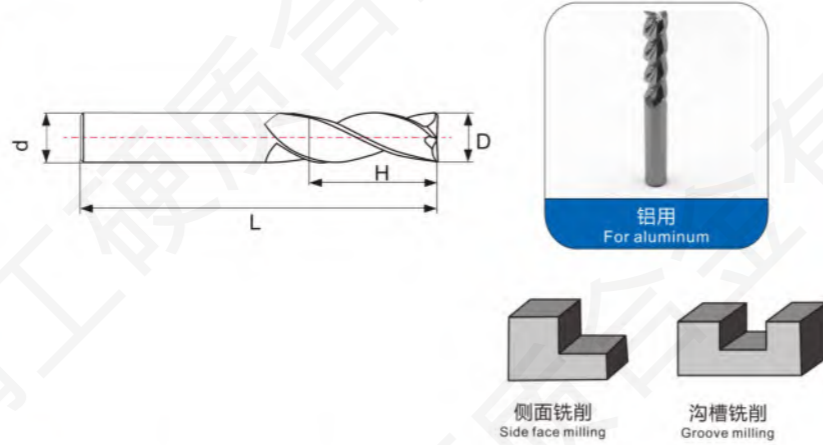

订货号 Specifications	刃径D(mm) Tool Diameter	R角/半径R Angle/ Radius	刃长H(mm) Flute Length	全长L(mm) Overall Length	柄径d(mm) Shank Diameter	刃数 Number of teeth	库存 Stock
JNM-3P-D3.0M-50	3.0	/	9	50	4	3	●
JNM-3P-D4.0M-50	4.0	/	12	50	4	3	●
JNM-3P-D3.0-50	3.0	/	9	50	6	3	●
JNM-3P-D4.0-50	4.0	/	12	50	6	3	●
JNM-3P-D5.0-50	5.0	/	15	50	6	3	●
JNM-3P-D6.0-60	6.0	/	18	60	6	3	●
JNM-3P-D8.0-60	8.0	/	20	60	8	3	●
JNM-3P-D10.0-75	10.0	/	30	75	10	3	●
JNM-3P-D12.0-75	12.0	/	32	75	12	3	●
JNM-3P-D16.0-100	16.0	/	45	100	16	3	●
JNM-3P-D20.0-100	20.0	/	45	100	20	3	●

● 常备库存 Standing stock ○ 按订单生产 Make to order

被加工材料适用表 (■ 非常适合 □ 适合)

Applicable Table of Processed Materials (■ Perfect Suitable □ Suitable)

被加工材料 Processed Material											
碳素钢 Carbon steel	合金钢 Alloy steel	预硬钢、淬硬钢 Pre-hardened steel, Hardened steel				不锈钢 Stainless steel	铸铁 cast iron 球墨铸铁 ductile iron	铜合金 Copper Alloy	铝合金 Aluminum Alloy	钛合金 Titanium Alloy	耐热合金 Heat-resisting Alloy
		~40HRC	~50HRC	~55HRC	~68HRC						
									■		

立铣刀常见问题及对策

Common problems and solutions for end mill

解决方法 Solutions	刀具材料选择 Tool material 选择涂层铣刀 Select coated end mill	切削条件 Cutting condition						刀具形状 Tool shape			机床装夹 Machine clamping						
		切削速度 Cutting speed	进给量 Feed rate	切削深度 Cutting depth	切削方向(顺铣/逆铣) Cutting direction(down/up milling)	切削液 Cutting liquid 增大切削液量 Increase the amount of cutting liquid 非水溶性切削液 Water-insoluble cutting liquid 干式或湿式 Dry or wet machining			螺旋角 Helical angle	刃数 Number of tooth	铣刀直径 Milling diameter	减少刀具悬伸量 Reduce the overhang length	提高刀具安装精度 Improve tool clamping precision	更换夹头 Change collet	提高夹紧力 Increase clamping force	提高工件安装刚性 Improve workpiece clamping rigidity	
常见问题 Common Problems																	
刀具折断 Tool fracture	立铣刀折断 Fracture of end mill		↓	↓					↓	↑	✓		✓	✓			
切削刃损伤 Damage of cutting edge	切削刃磨损较快 Rapid wear of cutting edge	✓	↓	↑	顺 Down	✓				↑							
	崩刃 Breakage		↓	↓	顺 Down		干 Dry				✓		✓		✓		
	切屑粘结严重 Severe chips bond	✓				✓	湿 Wet	↑									
加工精度 Machining precision	表面质量差 Poor surface quality		↑	↓	↓	✓	湿 Wet						✓				
	起伏 Uneven			↓	↓				↓	↑	↑		✓	✓			
	侧面不平 Uneven side face of workpiece			↓	↓	逆 UP	✓		↑	↑	↑	✓					
	毛刺及崩碎、剥落 Burr, breakage and slice frittering			↓	↓				↓								
	振动较大 Large vibration		↓	↑					↑	↓	↑	✓		✓	✓	✓	
切屑处理 Chip control	切屑排出不畅 Obstructed chip removal			↓	↓	✓				↓							
其他 Others																	

1. 刀刃磨损过大时，容易导致铣刀折断或加工面精度较差，此时需要对刀具进行重磨。
Large abrasion of cutting edge is easy to cause fracture of end mill or poor surface quality, so it is recommended to regrind the end mills.
2. 刀具悬伸量应尽可能短。
Make overhang of tool as short as possible.

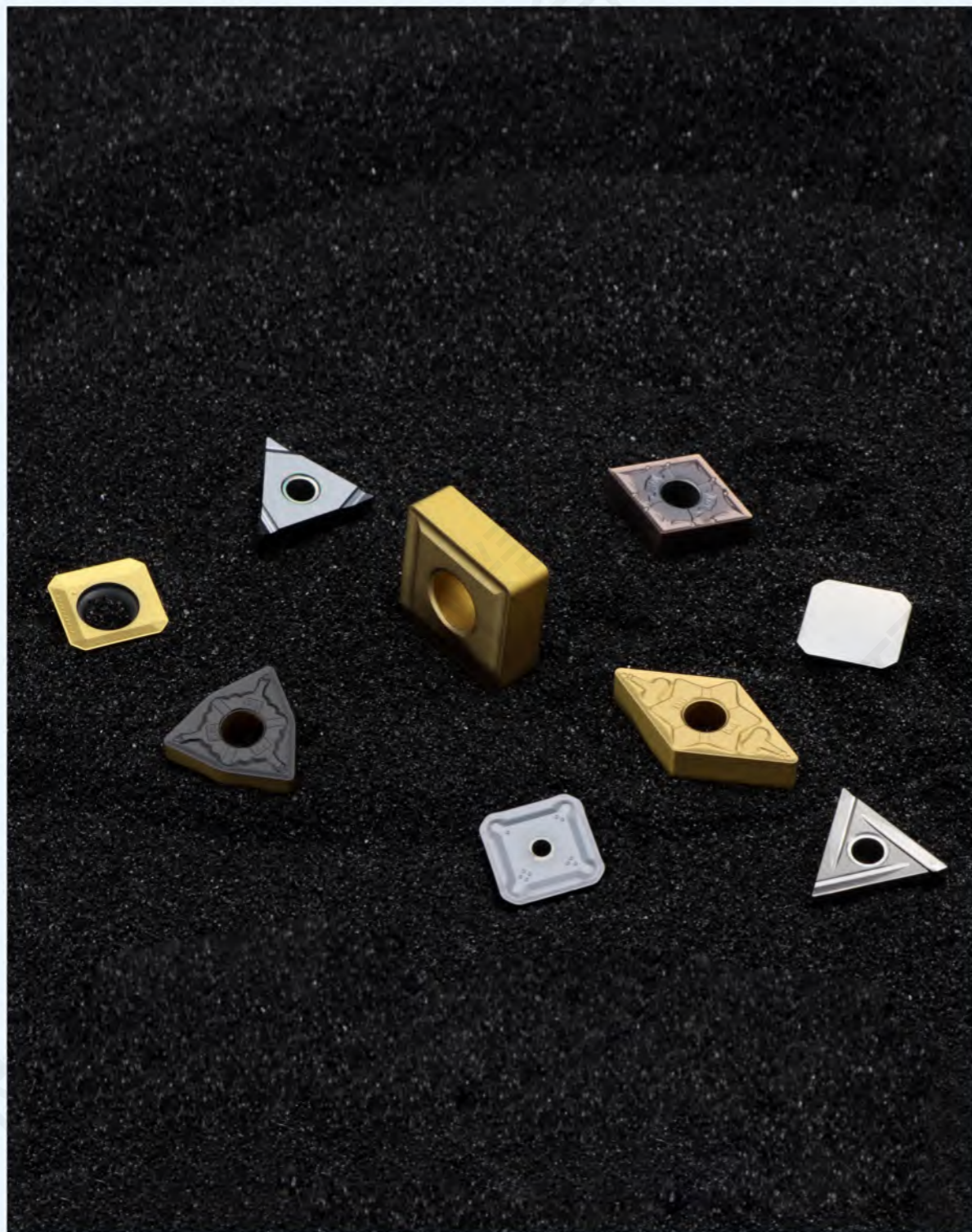

通用信息 技 术

General Technical Information



刀具规格选用办法 Selection Method of Cutting Tools	131
牌号对照表 Grade Comparison Table	133
硬度对照表 Hardness Comparison Table	135
安全使用注意事项 Precautions for Safe Use of Cutting Tools	136
硬质合金产品安全标准 Safety Standard for Cemented Carbide Products	137



刀具规格选用办法

Selection Method of Cutting Tools

普通车削刀具规格选用办法:

- 首先要了解您所需要加工的材料状况, 机床型号及状态。
- 选择适合的刀片形状, 切削主偏角及刀片压紧方式。
- 依据以上因素及您的机床型号来确定刀杆的左右方向及尺寸等明细。
- 最后确定与以上各因素相应的刀片规格、槽型、牌号。

切断切槽刀具规格选用办法:

- 首先要了解您所需加工的材料状况, 机床型号及状态。
- 根据加工方式(外圆、内孔、端面槽)确定切刀的基本类型。
- 依据以上因素及您的机床型号来确定刀杆的左右方向及尺寸等明细。
- 最后确定与以上各因素相应的刀片规格、定位方式、槽型、牌号等明细。

螺纹切削刀具规格选用办法:

- 首先要了解您所需加工的材料状况、机床型号及状态。
- 根据螺纹的制式、类型、加工方式初步确定刀具的类型。
- 依据以上因素及您的机床型号来确定刀杆的左右方向及尺寸等明细。
- 最后确定与以上各因素相应的刀片规格、槽型、牌号。

Selection Method of General Turning Tools:

- Understand the processed material condition, machine model and condition.
- Select the suitable insert shape, setting angle and clamping designation.
- Select details of tool bars as L/R, dimension, etc, according to above conditions
- Select the type, chip breaker and grade of inserts, corresponding to all conditions.

Selection Method of Parting and Grooving tools:

- Understand the processed material condition, machine model and condition.
- Select the basic type according to processing methods(external, internal, face grooving
- Select details of tool bars as L/R, dimension etc, according to above conditions,
- Select the type, clamping designation, chip-breaker and grade of inserts, corresponding to all conditions.

Selection Method of Threading Tools:

- Understand the processed material condition, machine model and condition.
- Select the tool type according to thread's type, processing methods, etc.
- Select details of tool bars as L/R, dimension, etc, according to above conditions,
- Select the type, chip-breaker and grade of inserts, corresponding to all conditions.

刀具规格选用办法

Selection Method of Cutting Tools

铣削刀具规格选用办法:

- 首先要了解您所需加工的材料状况, 机床型号及状态。
- 根据加工方式来确定铣削刀具的基本类型(平面铣削、方肩铣、仿形铣、铣槽、倒角铣等)。
- 根据加工精度及加工面形状与尺寸等因素确定采用整体铣刀或可转位铣刀。
- 依据以上因素及您的机床型号来确定刀具的接口、尺寸等明细。
- 最后确定与以上各因素相应的刀片规格、槽型、牌号。

孔加工刀具规格选用办法:

- 首先要了解您所需加工的材料状况、机床型号及状态。
- 根据加工工艺来确定孔加工刀具的基本类型(钻削、镗削、铰削、螺纹加工等方式)。
- 根据加工精度及加工孔的尺寸等因素确定采用整体刀具或可转位孔加工刀具。
- 依据以上因素及您的机床型号来确定刀具的接口、尺寸等明细。
- 最后确定与以上各因素相应的刀片规格、槽型、牌号。

Selection Method of Milling Tools :

- Understand the processed material condition, machine model and condition.
- Select the basic type of milling tools according to the processing method (plane milling, square shoulder milling, profile milling, milling grooves, chamfer milling, etc.).
- Select solid milling tools or indexable milling inserts according to machining accuracy and machining surface shape and size and etc.
- Select interface, size and other details of milling tools according to machine model and above conditions
- Select the type, chip-breaker and grade of Inserts, corresponding to all conditions.

Selection Method for Hole Processing Tools:

- Understand the processed material condition, machine model and condition.
- Select the basic types of hole processing tools (drilling, boring, reaming, thread processing, etc. according to machining process.
- Select solid cutting tools or indexable hole processing tools according to the machining accuracy and dimension of the machining holes.
- Select interface, size and other details of milling tools according to machine model and above conditions
- Select the type, chip-breaker and grade of Inserts, corresponding to all conditions.

牌号对照表

Grade Comparison Table

类别 Category	使用分类牌号 Classification grade		SANDVIK	KENNAMETAL	ISCAR	MITSUBISHI	TUNGALOY	KYOCERA	KORLOY	TaeguTec	SUMITOMO
	分类 Classification	牌号 Grade	山特维克	肯纳金属	伊斯卡	三菱	泰珂洛	京瓷	可乐伊	特固克	住友电气工业
车削 Turning	P	JGA05A		KC5010			AH710	PR915			
		JGA10A	GC1525 GC1025	KU10T KC5025	IC250 IC507	VP10MF	AH710	PR1005 PR915	PC230		
		JGA20F	GC1020 GC1125	KC7015 KC7020	IC928 IC1008	VP15TF	GH330 GH730	PR930 PR1025	PC230		
		JGP25T	GC4225 GC4215	KCP25 KC9125	IC9250 IC9054	UE6010 UE6020	T9015 T9025	CA5515 CA5025 CA9025	NC3020	TT1500	AC2000 AC3000
		JGP25S	GC4225 GC4235	KCP30 KCP40	IC8350 IC9350	UH6400 UE6035	T9025 T9035	CA5525 CA5535	NC330	TT3500 TT5100	AC830P AC3000
		JGP40T	GC4235 GC4035	KC9140 KC9040	IC9350 IC656	UH6400 US735	T9005	CA5535		TT450	AC630M
	M	JGA10A	GC1025	KC5010 KC5510	IC507 IC907	VP10MF	GH330	PR915 PR1225	PC9030		AC510N
		JGA20F	GC1020	KC5025 KC735	IC250 IC354	VP15TF	GH770	PR930 PR1125	PC9030		AC520U AC530U
		JGM30R	GC2135 GC235	KCM25 KC9240	IC656 IC9025	US735	T6030	CA6525			AC630M
	K	JGK10R	GC3205 GC3215	KCK05 KCK15	IC9150 IC9015 IC418	UC5105 UC5115	T5010	CA4010 CA4515	N305K	TT1300	AC410K AC700G
		JGK20R	GC3215	KCK20 KC9315	IC4010	UE6110 UC5115	T5020	CA4010 CA4115	N315K	TT1500	AC700G

牌号对照表

Grade Comparison Table

类别 Category	使用分类代号 Classification code		SANDVIK	KENNAMETAL	ISCAR	MITSUBISHI	TUNGALOY	KYOCERA	KORLOY	TaeguTec	SUMITOMO
	分类 Classification	代号 code	山特维克	肯纳金属	伊斯卡	三菱	泰珂洛	京瓷	可乐伊	特固克	住友电气工业
铣削 Milling	P	JGA05A	GC1010		IC250						ACP100
		JGA10A	GC1025	KC715M	IC903 IC950	VP15TF		PR730 PR830 PR1025	PC230	TT7030	ACZ310 ACP100
		JGA20H	GC1025	KC522M	IC950 IC900	VP15TF		PR630 PR1225	PC3530	TT7070 TT9030	ACZ330 ACP200
		JGA20F	GC1010 GC2030	KC525M	IC908 IC910	VP15TF VP30RT	GH330 AH330	PR660 PR830	PC130	TT8020	ACZ300 ACZ350
		JGP25T	GC4230	TN7525	IC520M	FH7030					AC230
		JGP25S	GC4240 GC4040	TN7535 KC935M	IC4050	FH7020 FH7030	T3030		NCM335	TT7300	AC230
	M	JGA10A	GC1025 GC2030	KC715M KC730	IC903	VP15TF FH7030 VP20RT	GH330	PR630 PR660 PR730			ACP200
		JGA05A	GC1030	KC522M	IC900 IC928	VP15TF	AH120	PR830 PR1225			ACZ310 EH20Z ACP300
		JGM30R		TN7525	IC4050	FH7030					
	K	JGK10R	GC3220 K20D	TN5515 TN5520	IC9080 IC4100	MC5020 F5010	T1015	IC9080 IC4100	NCM310		ACK200 AC211
		JGK20R	GC3040	KC915M KC930M	IC520M IC5100	MC5020 F5020	T1015		NCM320		ACK200

硬度对照表 (黑色金属硬度及强度近似换算值)

Hardness Comparison Table (Approximate conversion on hardness & strength of ferrous metals)

硬度 Hardness				抗弯强度 TRS (N/mm ²)	硬度 Hardness				抗弯强度 TRS (N/mm ²)
洛氏 Rockwell HRC	洛氏 Rockwell HRA	维氏 Vickers HV	布氏 Brinell HB		洛氏 Rockwell HRC	洛氏 Rockwell HRA	维氏 Vickers HV	布氏 Brinell HB	
70.0	86.6	1037	—	—	43.0	72.1	411	401	1360
69.5	86.3	1017	—	—	42.5	71.8	405	396	1340
69.0	86.1	997	—	—	42.0	71.6	399	391	1320
68.5	85.8	978	—	—	41.5	71.3	393	385	1300
68.0	85.5	959	—	—	41.0	71.1	388	380	1280
67.5	85.2	941	—	—	40.5	70.8	382	375	1260
67.0	85.0	923	—	—	40.0	70.5	377	370	1245
66.5	84.7	906	—	—	39.5	70.3	372	365	1225
66.0	84.4	889	—	—	39.0	70.0	367	360	1210
65.5	84.1	872	—	—	38.5	—	362	355	1190
65.0	83.9	856	—	—	38.0	—	357	350	1175
64.5	83.6	840	—	—	37.5	—	352	345	1160
64.0	83.3	825	—	—	37.0	—	347	341	1140
63.5	83.1	810	—	—	36.5	—	342	336	1125
63.0	82.8	795	—	—	36.0	—	338	332	1110
62.5	82.5	780	—	—	35.5	—	333	327	1095
62.0	82.2	766	—	—	35.0	—	329	323	1080
61.5	82.0	752	—	—	34.5	—	324	318	1065
61.0	81.7	739	—	—	34.0	—	320	314	1050
60.5	81.4	726	—	—	33.5	—	316	310	1035
60.0	81.2	713	—	2555	33.0	—	312	306	1020
59.5	80.9	700	—	2500	32.5	—	308	302	1010
59.0	80.6	688	—	2450	32.0	—	304	298	298
58.5	80.3	676	—	2395	31.5	—	300	294	294
58.0	80.1	664	—	2345	31.0	—	296	291	291
57.5	79.8	653	—	2295	30.5	—	292	287	287
57.0	79.5	642	—	2250	30.0	—	289	283	283
56.5	79.3	631	—	2205	29.5	—	285	280	280
56.0	79.0	620	—	2160	29.0	—	281	276	276
55.5	78.7	609	—	2115	28.5	—	278	273	273
55.0	78.5	599	—	2075	28.0	—	274	269	269
54.5	78.2	589	—	2035	27.5	—	271	266	266
54.0	77.9	579	—	1995	27.0	—	268	263	263
53.5	77.7	570	—	1955	26.5	—	264	260	260
53.0	77.4	561	—	1920	26.0	—	261	257	257
52.5	77.1	551	—	1885	25.5	—	258	254	254
52.0	76.9	543	—	1850	25.0	—	255	251	251
51.5	76.9	534	—	1815	24.5	—	252	248	248
51.0	76.3	525	501	1780	24.0	—	249	245	820
50.5	76.1	517	494	1750	23.5	—	246	242	810
50.0	75.8	509	488	1720	23.0	—	243	240	800
49.5	75.5	501	481	1690	22.5	—	240	237	790
49.0	75.3	493	474	1660	22.0	—	237	234	785
48.5	75.0	485	468	1630	21.5	—	234	232	775
48.0	74.7	478	461	1605	21.0	—	231	229	765
47.5	74.5	470	455	1575	20.5	—	229	227	760
47.0	74.2	463	449	1550	20.0	—	226	225	750
46.5	73.9	456	442	1525	19.5	—	223	222	745
46.0	73.7	449	436	1500	19.0	—	221	220	735
45.5	73.4	443	430	1475	18.5	—	218	218	730
45.0	73.2	436	424	1450	18.0	—	216	216	725
44.5	72.9	429	418	1430	17.5	—	214	214	715
44.0	72.6	423	413	1405	17.0	—	211	211	710
43.5	72.4	417	407	1385					

注: 此表所列各个钢系的换算值, 对含碳量由低到高的钢种基本适用。The conversion values for all steels listed in this table are basically applicable to steels with low to high carbon content. 此表所列的抗拉强度值, 适用于换算精度要求不高的一般钢种, 1N/mm²=1Mpa。The tensile strength values listed in this table are suitable for general steels with low conversion accuracy. 此表摘自GB1172-74。This table is taken from GB1172-74.

安全使用切削工具的注意事项

Precautions for Safe Use of Cutting Tools

危险性 Hazard	防护措施 Protective Measures
直接接触切削刀具锋利的刀刃可能对人体造成伤害。 Direct contact with the sharp edge of the cutting tool may cause injury to human body.	当您在机床上安装或拆卸切削刀具时, 请使用手套等防护劳保用品。 When you install or remove cutting tools on the machine tool, please use protective labor protection appliances such as gloves.
不恰当地使用刀具可能导致其破损, 附件飞出, 引起损害。 Improper use of the tool may cause its breakage and accessories flying out, resulting in the damage.	使用前阅读样本和安全标准。 Read samples and safety standards before use. 请使用防护眼镜和防护服。 Please use safety glasses and protective clothing.
过度磨损和剧烈冲击使切削阻力剧增, 可能导致刀具破裂而飞溅, 对操作者造成伤害。 Excessive wear and severe impact increase the cutting resistance, which may lead to tool fracture and splashing, causing injury to the operator.	及时更换过度磨损的刀具。 Replace excessively worn tools in time. 请使用防护眼镜和防护服。 Please use safety glasses and protective clothing.
切削过程中的切屑可能对人造成烫伤和划伤。 Chips during cutting may cause burns and scratches to people.	及时使用钳子等工具清除切屑。 Timely use pliers and other tools to remove chips. 请使用防护眼镜和防护服以及防护手套。 Please use safety glasses, protective clothing and protective gloves.
切削过程中产生的火花和高温切屑有引发火灾和爆炸的危险。 The sparks and high temperature chips produced in the cutting process are dangerous and may cause fire and explosion.	清除在切削区域的易燃易爆物品。 Remove flammable and explosive materials in the cutting area. 请做好灭火器准备。 Please prepare fire-fighting equipment.
高速运行的机床由于夹具等的平衡性差而引起剧烈振动, 导致刀具破损。 The high-speed running machine tools vibrate violently because of the poor balance of the fixture and so on, resulting in the tool damage.	在切削前, 检查设备是否有松动或者异常声音。 Before cutting, check whether the equipment is loose or abnormal. 请使用防护眼镜和防护服。 Please use safety glasses and protective clothing.
被加工件上的毛刺等缺陷非常锋利, 很容易划伤人体。 The defects such as burrs on the machined parts are very sharp and easy to scratch the human body.	请不要触摸被加工件上的毛刺。 Please do not touch the burrs on the machined part. 请使用防护眼镜和防护服。 Please use safety glasses and protective clothing.
没有夹紧被加工件就直接进行加工会造成刀具破损和被加工件的飞溅。 If the workpiece is machined directly without clamping, the tool will be damaged and the workpiece will splash.	必须把被加工件牢牢夹住。 The machined part must be firmly clamped. 请使用防护眼镜和防护服。 Please use safety glasses and protective clothing.
在刀片或刀片附件没有夹紧妥当的情况下进行切削, 有刀具脱落飞出造成危险的危险。 When the blade or its accessories are not clamped properly, there is a risk of injury caused by the falling off of the tool.	加工前确认刀片以及其他附件已经使用恰当的工具紧固妥当。 Before machining, please make sure that the blades and other accessories have been fastened properly with appropriate tools.
用螺销或压板等辅助工具过分紧固时, 刀片或者刀具有破碎飞溅的危险。 When the auxiliary tools such as screw pins or pressing plates are used for over-tightening, the blade or knife may be in the risk of breaking and flying.	请不要使用套管等辅助工具过分紧固。 Do not overtighten with auxiliary tools such as sleeves.
刀片或附件在高速切削时, 有可能因惯性离心力的作用下脱落飞出。 In high speed cutting, the blade or accessories may fall off and fly out under the action of inertial centrifugal force.	请在推荐范围内使用刀具。 Please use the tool within the recommended range. 请使用防护眼镜和防护服。 Please use safety glasses and protective clothing.
由于铣削刀具的边锋利, 直接用手触摸有被划伤的危险。 Because the edge of milling tool is sharp, it is dangerous to be scratched by touching directly with hands.	为了您的安全, 在必须接触刀片的情况下带好防护手套。 For your safety, please wear protective gloves when you have to touch the blade.
旋转切削中, 衣服、手套等很容易被绞到高速运行的设备中, 造成人员伤亡。 In rotary cutting process, clothes, gloves and so on are easily twisted into high-speed running equipment, resulting in casualties.	当您在进行旋转切削中, 请不要带手套加工。 When you are doing rotary cutting, please do not wear gloves. 时刻注意不要让衣服等接触运行中的机床部件。 Always be careful not to let clothes and other running machine parts in contact each other.
偏心旋转或平衡不良的工具在旋转加工时会产生晃动振动而引起破损飞溅导致伤害。 The tool with eccentric rotation or poor balance will have shaking vibration in rotation processing, which will cause damage and flying, resulting in injury.	请在容许转速范围内使用刀具。 Please use the tool within the allowable speed range. 定期检查机械的平衡性能。 Check the mechanical balance performance of the machine regularly.
在高速切削时, 高速飞出的切屑有可能造成伤害。 In high speed cutting, chips flying out at high speed may cause injury.	使用安全罩、保护屏、外罩等。 Use safety cover, protective screen, outer cover, etc. 请使用防护眼镜和防护服。 Please use safety glasses and protective clothing.
用极小的刀具进行钻削时, 容易造成刀具折断飞溅和无法取出的可能。 When drilling with a very small tool, it is easy to cause the tool to break and fly and cannot be removed.	减小刀具振动和在合适的运行速度下加工。 Reduce the vibration of the tool and machine at a suitable operating speed. 请使用防护眼镜和防护服。 Please use safety glasses and protective clothing.
在规定用途外使用, 会导致机床和刀具的加速损坏, 并引发其他危险。 If it is used outside for the specified purpose, it will cause accelerated damage to the machine tools and cutting tools, and cause other hazards.	请按照说明规定使用。 Please follow the instructions.

硬质合金产品安全标准

Safety Standard for Cemented Carbide Products

1、安全责任

在使用株洲精工硬质合金有限公司生产的产品前，请对操作者进行必要的安全培训，并请您仔细阅读产品包装上的“注意”和“警告”内容，对于没有按要求使用所造成的不良后果，本公司不负任何法律责任。

2、硬质合金材料基本特征

硬质合金是由W、C、Co、Ti、Ta、Nb等元素及其化合物经过烧结成型，并且进行一系列的后续加工而形成的加工工具。硬质合金有着很好的化学稳定性和很高的强度，是加工大部分金属和大量高强度非金属的理想工具。

3、使用硬质合金产品的注意事项

- 硬质合金是硬而脆的材料，在过大的作用力或者某些特定的局部应力作用下脆裂破损，并带有锋利的刃口。
- 大部分硬质合金以钨、钴为主要成分，密度很大，在运送和储存应作重物处理，小心轻放。
- 硬质合金产品应存放在干燥，无腐蚀性气氛的环境中。
- 硬质合金产品在使用过程中，如产生切屑，脆片等，请在加工前准备必要的劳保用品。

1. Security Responsibility

Before the use of the cemented carbide products manufactured by Zhuzhou Jingong Cemented Carbide Co., Ltd., please make the necessary training for the operator, and read carefully the "caution" and "warning" contents on the product packaging. For the adverse consequences caused by failure to use the products, the company does not bear any legal responsibility.

2. Basic Characteristics of cemented carbide materials

Cemented carbide is made up of the elements such as W, C, Co, Ti, Ta, Nb and etc, and other compounds, and was formed through the process of sintering and a series of subsequent processing. Cemented carbide has good chemical stability and high strength, and is an ideal tool for the processing of most metals and a large number of high strength non-metals.

3. Precautions for using cemented carbide

- Cemented carbide is a kind of hard and brittle material, which can be cracked and damaged under the action of a large force and some particular local stress, and with a sharp edge.
- Most of cemented carbide has tungsten and cobalt as the main components, and the density is very large. In transportation and storage, please be careful and regard the product as heavy cargo.
- Cemented carbide products should be stored in a dry, non-corrosive atmosphere environment.
- In the use of the cemented carbide products, if some cuttings and chips were produced, please prepare some necessary PPE before processing.