

圣达刀具  
SANT CNC TOOLS

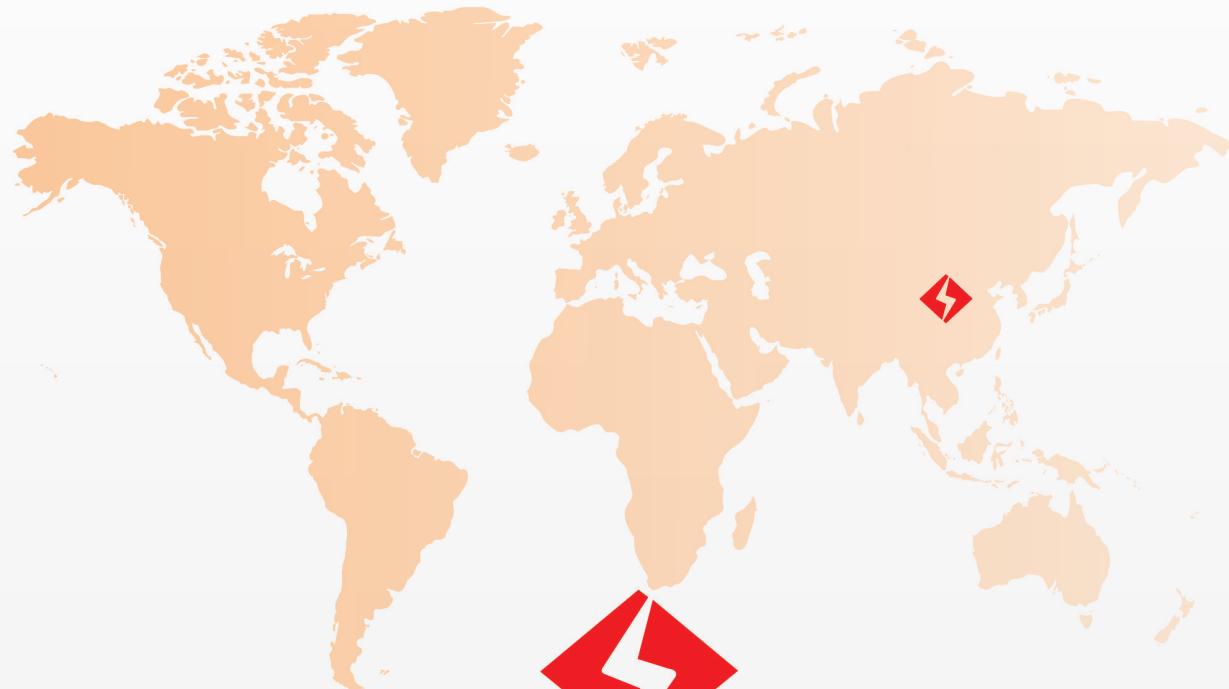

株洲圣达切削刀具有限公司  
ZHUSHOU SANT CUTTING TOOLS CO.,LTD.

地址：中国\*湖南省株洲市天元区黑龙江路638号圣达精密产业园  
Add: SANT Precision Industrial Park, No 638 Heilongjiang Road,  
Tianyuan District, Zhuzhou City, Hunan Province P.R.China

电话 (Tel) : 86-731-28822550 28822551 28822559

传真 (Fax) : 86-731-28822560

网址 (Web site) : [www.hnsant.com](http://www.hnsant.com)

[hnsant.en.alibaba.com](http://hnsant.en.alibaba.com)

[hnsant123.en.made-in-China.com](http://hnsant123.en.made-in-China.com)

QQ: 2850967303 2850967302 2850967301

Email: [sales@hnsant.com](mailto:sales@hnsant.com) [admin@hnsant.com.cn](mailto:admin@hnsant.com.cn)

SKYPE:2850967300@qq.com



## 阻尼减振车刀型录

 株洲圣达切削刀具有限公司  
SANT ZHUSHOU SANT CUTTING TOOLS CO.,LTD.

# 阻尼减振刀具 DAMPING TOOLS

## 阻尼减振车刀 Damping Turning Tool

阻尼减振车刀杆 ..... B2	Damping Turning Tool Holder
阻尼减振车刀刀头 ..... B11	Cartridge For Damping Turning Tool Holder
槽刀头 ..... B30	Grooving Head
螺纹刀头 ..... B31	Threading Tool Cartridge
中心校准块 ..... B32	Centre Calibration Block
快换刀座 ..... B32	Quick-Change Cartridge
车床用变径套 ..... B33	Reduction Sleeve for Turning Lathe
车刀转接头 ..... B34	Adapter for Head
刀杆转接头 ..... B34	Adapter for Tool Holder
阻尼减振车刀使用说明 ..... B35	User Guide for Damping Turning Tool

## DAMPING TURNING TOOL 阻尼减振车刀

### 阻尼减振车刀杆 Damping Turning Tool Holder

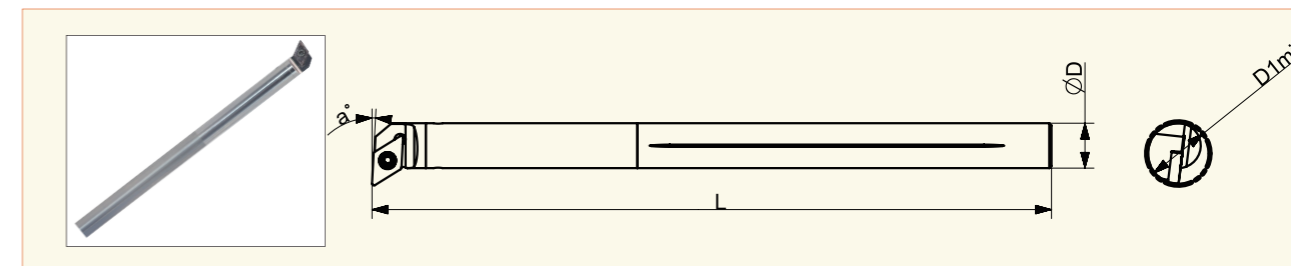

规格型号 Designation	D	L	D1min	a'	L/D	Kg	适配刀头 Cartridge	在庫 Stock
SVT08M-SCLPR06	08	150	10	5	11	0.1	CP..0602..	●
SVT10M-SCLCR06	10	150	12	5	11	0.12	CC..0602..	●
SVT10M-SDUCR07	10	150	14	3	11	0.15	DC..0702..	●
SVT12Q-SCLCR06	12	180	14	5	11	0.23	CC..0602..	●
SVT12Q-SDUCR07	12	180	16	3	11	0.25	DC..0702..	●

- 推荐最小夹紧长度为 4xD。
- 刀杆有内冷出水孔。
- 适配刀头需单独订购，请参照：☞ B11-B31 页。
- 若出现减振性能下降时，建议维修保养。
- 订货示例：1 件 SVT08M-SCLPR06。
- Suggested min. Length is 4xD.
- With coolant hole.
- The cartridge should be ordered separately, please see page B11-B31.
- The reducing head should be ordered separately.
- Suggest doing the maintenance when damping capacity is weaker than before.
- Ordering sample: 1 PC SVT08M-SCLPR06.

### 备件

Spare Parts

规格型号	刀片锁紧螺钉 Clamp screw for cartridge	刀片锁紧扳手 Allen key for cartridge clamping screw
SVT08M-SCLPR06	SR21 M2.5*5.3	KEY03 T7
SVT10M-SCLCR06	SR21 M2.5x5.3	KEY03 T7
SVT10M-SDUCR07	SR21 M2.5x5.3	KEY03 T7
SVT12Q-SCLCR06	SR21 M2.5x5.3	KEY03 T7
SVT12Q-SDUCR07	SR21 M2.5x5.3	KEY03 T7

# DAMPING TURNING TOOL 阻尼减振车刀

## 阻尼减振车刀杆

Damping Turning Tool Holder

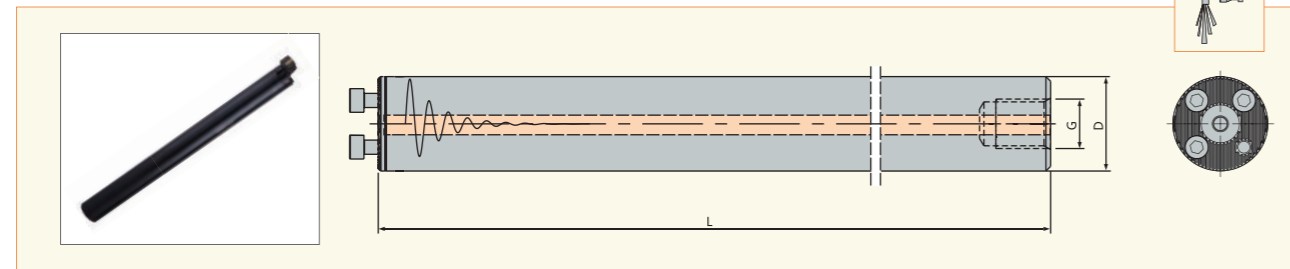

规格型号 Designation	D	L	G	L/D	Kg	适配刀头 Cartridge	在庫 Stock
SVT16 C16-L156V	16	156	G1/8"	7	0.2	VT16..	●
SVT16 C16-L204VE	16	204	-	10	0.5	VT16..	●
SVT20 C20-L200V	20	200	G1/4"	7	0.4	VT20..	●
SVT20 C20-L260VE	20	260	-	10	0.8	VT20..	●
SVT25 C25-L255V	25	255	G1/4"	7	1.0	VT25..	●
SVT25 C25-L330V	25	330	G1/4"	10	1.3	VT25..	●
SVT25 C25-L380VE	25	380	G1/8"	12	2.0	VT25..	○
SVT25 C25-L430VE	25	430	G1/8"	14	2.6	VT25..	○
SVT32 C32-L320V	32	320	G3/8"	7	2.1	VT32..	●
SVT32 C32-L416V	32	416	G3/8"	10	2.8	VT32..	●
SVT32 C32-L480VE	32	480	G1/4"	12	4.2	VT32..	○
SVT32 C32-L544VE	32	544	G1/4"	14	4.8	VT32..	○
SVT40 C40-L408V	40	408	G1/2"	7	4.6	VT40..	●
SVT40 C40-L528V	40	528	G1/2"	10	5.3	VT40..	●
SVT40 C40-L608VE	40	608	G3/8"	12	8.3	VT40..	○
SVT40 C40-L688VE	40	688	G3/8"	14	9.4	VT40..	○

- 推荐最小夹紧长度为 4xD。
- 刀杆有内冷出水孔。
- 适配刀头需单独订购，请参照：☞ B11-B31 页。
- 若出现减振性能下降时，建议维修保养。
- 订货示例：1 件 SVT16 C16-L156V。
- Suggested min. Length is 4xD.
- With coolant hole.
- The cartridge should be ordered separately, please see page B11-B31.
- The reducing head should be ordered separately.
- Suggest doing the maintenance when damping capacity is weaker than before.
- Ordering sample: 1 PC SVT16 C16-L156V.

## 备件

Spare Parts

D	刀头锁紧螺钉 Clamp screw for cartridge	刀头锁紧扳手 Allen key for cartridge clamping screw
16	SR55-2 M3x10	KEY01 M2.5
20	SR55-2 M3.5x10	KEY01 M2.5
25	SR55-2 M4x12	KEY01 M3
32	SR55-2 M5x12	KEY01 M4
40	SR55-2 M6x16	KEY01 M5

● 标准库存  
Item in stock

● 半标准库存 (订货时, 请确认交货期)  
Item of short delivery time  
(please confirm delivery time when ordering it)

○ 无库存 (订货时, 请确认交货期)  
Order on demand  
(please confirm delivery time when ordering it)

# DAMPING TURNING TOOL 阻尼减振车刀

## 阻尼减振车刀杆

Damping Turning Tool Holder

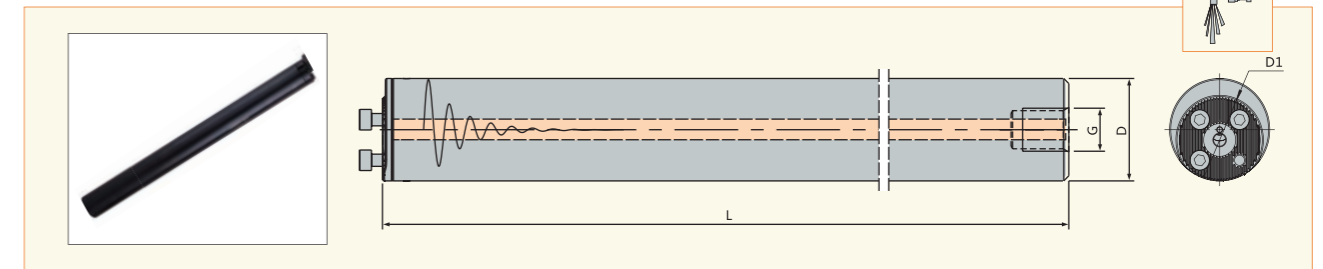

规格型号 Designation	D	D1	L	G	L/D	Dmin	Kg	适配刀头 Cartridge	在庫 Stock
SVT40 C50-L518V	50	40	518	G1/2"	7	60	7.2	VT40..	●
SVT40 C50-L668V	50	40	668	G1/2"	10	60	9.3	VT40..	●
SVT40 C50-L768VE	50	40	768	G1/2"	12	60	14.4	VT40..	○
SVT40 C50-L868VE	50	40	868	G1/2"	14	60	16.6	VT40..	○
SVT40 C60-L628V	60	40	628	G3/4"	7	70	12.5	VT40..	●
SVT40 C60-L808V	60	40	808	G3/4"	10	70	16.3	VT40..	●
SVT40 C60-L920VE	60	40	920	G3/4"	12	70	27.1	VT40..	○
SVT40 C60-L1040VE	60	40	1040	G3/4"	14	70	30.9	VT40..	○

- 推荐最小夹紧长度为 4xD。
- 刀杆有内冷出水孔。
- 适配刀头需单独订购，请参照：☞ B11-B31 页。
- 若出现减振性能下降时，建议维修保养。
- 订货示例：1 件 SVT40 C50-L518V。

- Suggested min. Length is 4xD.
- With coolant hole.
- The cartridge should be ordered separately, please see page B11-B31.
- Suggest doing the maintenance when damping capacity is weaker than before.
- Ordering sample: 1 PC SVT40 C50-L518V.

## 备件

Spare Parts

D1	刀头锁紧螺钉 Clamp screw for cartridge	刀头锁紧扳手 Allen key for cartridge clamping screw
40	SR55-2 M6X16	KEY01 M5

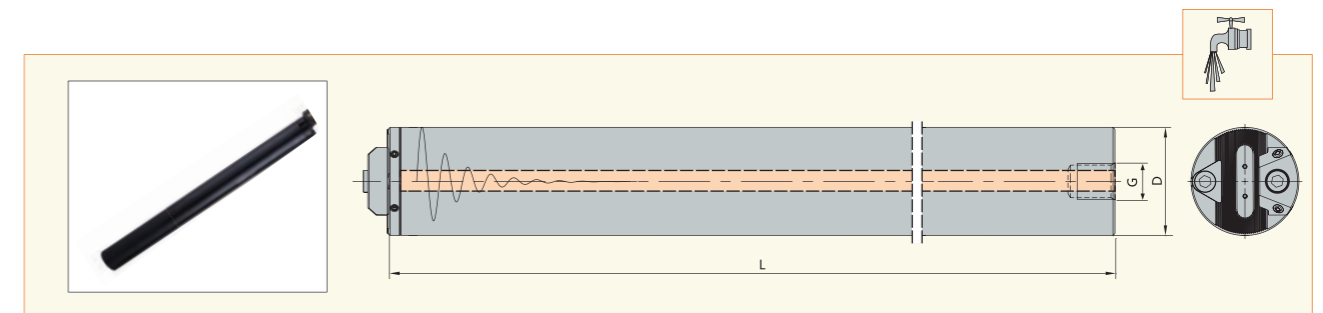

规格型号 Designation	D	L	G	L/D	Kg	适配刀头 Cartridge	在庫 Stock
SVH80 C80-L880V	80	880	G3/4"	7	31.8	VH80..	●
SVH80 C80-L1200V	80	1200	G3/4"	10	52.3	VH80..	●
SVH80 C80-L1240VE	80	1240	G3/4"	12	60	VH80..	○
SVH80 C80-L1400VE	80	1400	G3/4"	14	70	VH80..	○

- 推荐最小夹紧长度为 4xD。
- 刀杆有内冷出水孔。
- 适配刀头需单独订购，请参照：☞ B11-B31 页。
- 若出现减振性能下降时，建议维修保养。
- 订货示例：1 件 SVH80 C80-L880V。

- Suggested min. Length is 4xD.
- With coolant hole.
- The cartridge should be ordered separately, please see page B11-B31.
- Suggest to do the maintenance when damping capacity is weaker than before.
- Ordering sample: 1 PC SVH80 C80-L880V.

## 备件

Spare Parts

D	刀片锁紧螺钉 Clamping screw for insert	锁紧扳手 Allen key for clamping	上压板 Upper clamping pad	下压板 Lower clamping pad	压板弹簧 Spring clamping pad	定位螺钉 Clamp screw for cartridge
80	SR55 M10x25	KEY01 M8	PB20 M10x16.0	PB20 M10x11	YH 12.5x0.9x18	SR55 M3x6

● 标准库存  
Item in stock

● 半标准库存 (订货时, 请确认交货期)  
Item of short delivery time  
(please confirm delivery time when ordering it)

○ 无库存 (订货时, 请确认交货期)  
Order on demand  
(please confirm delivery time when ordering it)

# DAMPING TURNING TOOL 阻尼减振车刀

## 加强型阻尼减振车刀杆

Power Damping Turning Tool Holder

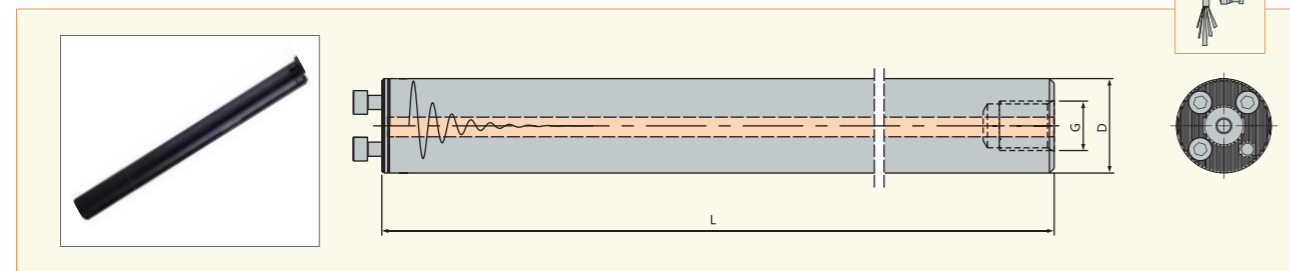

规格型号 Designation	D	L	G	L/D	Kg	适配刀头 Cartridge	在库 Stock
SVT32 C32-L256V.P	32	256	G3/8"	5	1.58	VT32..	●
SVT40 C40-L328V.P	40	328	G1/2"	5	3.01	VT40..	●
SVT40 C50-L418V.P	50	418	G1/2"	5	5.92	VT40..	●
SVT40 C60-L508V.P	60	508	G3/4"	5	10.48	VT40..	●

- 推荐最小夹紧长度为 4xD.
- 刀杆有内冷出水孔.
- 若出现减振性能下降时, 建议维修保养.
- 订货示例: 1 件 SVT32 C32-L256V.P.
- Suggested min. Length is 4xD.
- With coolant hole.
- Suggest doing the maintenance when damping capacity is weaker than before.
- Ordering sample: 1 PC SVT32 C32-L256V.P.

### 备件

Spare Parts

D	刀头锁紧螺钉 Clamp screw for cartridge	刀头锁紧扳手 Allen key for cartridge clamping screw
32	SR55-2 M5x12	KEY01 M4
40/50/60	SR55-2 M6x16	KEY01 M5

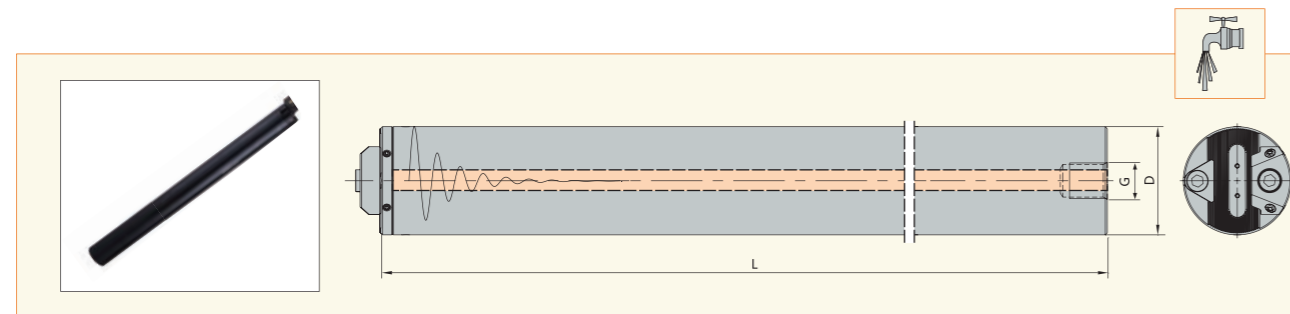

规格型号 Designation	D	L	G	L/D	Kg	适配刀头 Cartridge	在库 Stock
SVH80 C80-L720V.P	80	720	G3/4"	5	27.05	VH80..	●

- 推荐最小夹紧长度为 4xD.
- 刀杆有内冷出水孔.
- 若出现减振性能下降时, 建议维修保养.
- 订货示例: 1 件 SVH80 C80-L720V.P.
- Suggested min. Length is 4xD.
- With coolant hole.
- Suggest to do the maintenance when damping capacity is weaker than before.
- Ordering sample: 1 PC SVH80 C80-L720V.P.

### 备件

Spare Parts

D	刀片锁紧螺钉 Clamping screw for insert	锁紧扳手 Allen key for clamping	上压板 Upper clamping pad	下压板 Lower clamping pad	压板弹簧 Spring clamping pad	定位螺钉 Clamp screw for cartridge
80	SR55 M10x25	KEY01 M8	PB20 M10x16.0	PB20 M10x11	YH 12.5x0.9x18	SR55 M3x6

- 标准库存  
Item in stock
- 半标准库存 (订货时, 请确认交货期)  
Item of short delivery time  
(please confirm delivery time when ordering it)
- 无库存 (订货时, 请确认交货期)  
Order on demand  
(please confirm delivery time when ordering it)

# DAMPING TURNING TOOL 阻尼减振车刀

## 大直径阻尼减振车刀杆

Long Overhang Damping Turning Tool

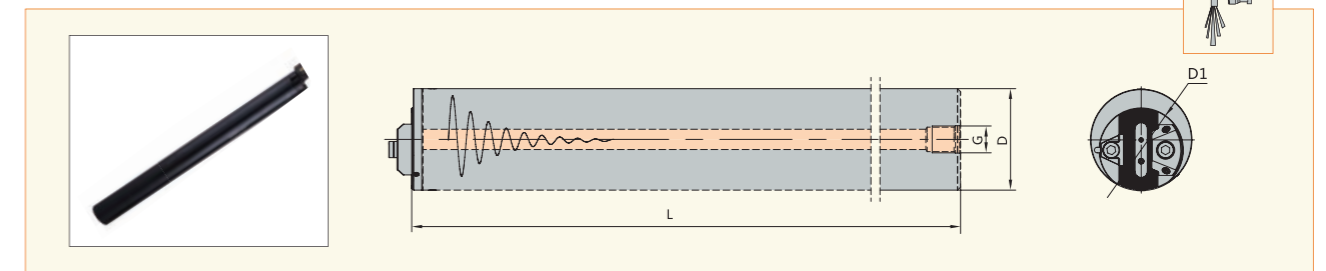

规格型号 Designation	D	D1	L	G	L/D	Kg	适配刀头 Cartridge	在库 Stock
SVH80 C100-L1100V	100	80	1100	G3/4"	7	63.4	VH80..	○
SVH80 C100-L1500V	100	80	1500	G3/4"	10	86.8	VH80..	○
SVH80 C120-L1900V.R/L	120	80	1900	G3/4"	10	134	VH80..	○
SVH80 C130-L2000V.R/L	130	80	2000	G3/4"	10	192.3	VH80..	○
SVH80 C140-L2200V.R/L	140	80	2200	G3/4"	10	241.5	VH80..	○
SVH80 C150-L2400V.R/L	150	80	2400	G3/4"	10	252.6	VH80..	○
SVH80 C160-L2600V.R/L	160	80	2600	G3/4"	10	339.3	VH80..	○
SVH80 C180-L2800V.R/L	180	80	2800	G3/4"	10	458.2	VH80..	○
SVH80 C200-L3200V.R/L	200	80	3200	G3/4"	10	657.7	VH80..	○
SVH80 C220-L3450V.R/L	220	80	3450	G1"	10	1059.3	VH80..	○
SVH80 C250-L4000V.R/L	250	80	4000	G1"	10	1229	VH80..	○

- 推荐最小夹紧长度为 4xD.
- 刀杆有内冷出水孔.
- 适配刀头需单独订购, 请参照: B11-B31 页.
- 若出现减振性能下降时, 建议维修保养.
- 订货示例: 1 件 SVH80 C100-L1100V.
- Suggested min. Length is 4xD.
- With coolant hole.
- The cartridge should be ordered separately, please see page B11-B31.
- Suggest doing the maintenance when damping capacity is weaker than before.
- Ordering sample: 1 PC SVH80 C100-L1100V.

### 备件

Spare Parts

D1	刀片锁紧螺钉 Clamping screw for insert	锁紧扳手 Allen key for clamping	上压板 Upper clamping pad	下压板 Lower clamping pad	压板弹簧 Spring clamping pad	定位螺钉 Clamp screw for cartridge
80	SR55 M10x25	KEY01 M8	PB20 M10x16.0	PB20 M10x11	YH 12.5x0.9x18	SR55 M3x6

- 标准库存  
Item in stock
- 半标准库存 (订货时, 请确认交货期)  
Item of short delivery time  
(please confirm delivery time when ordering it)
- 无库存 (订货时, 请确认交货期)  
Order on demand  
(please confirm delivery time when ordering it)

# DAMPING TURNING TOOL 阻尼减振车刀

## 大直径阻尼减振车刀杆

Long Overhang Damping Turning Tool

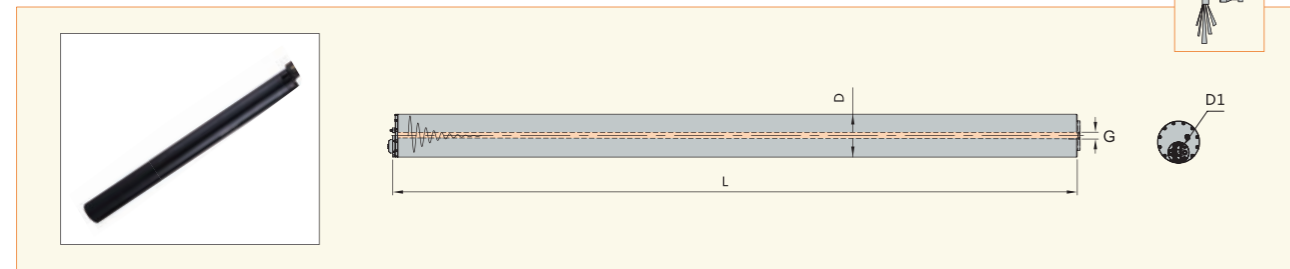

规格型号 Designation	D	D1	L	G	L/D	Kg	适配刀头 Cartridge	在庫 Stock
SVH80 C100-L1560VE	100	80	1560	G3/4"	12	117.6	VH80..	○
SVH80 C100-L1760VE	100	80	1760	G3/4"	14	133.3	VH80..	○
SVH80 C120-L1870VE.R/L	120	80	1870	G3/4"	12	215.7	VH80..	○
SVH80 C120-L2110VE.R/L	120	80	2110	G3/4"	14	248.6	VH80..	○
SVH80 C130-L2030VE.R/L	130	80	2030	G3/4"	12	271.4	VH80..	○
SVH80 C130-L2290VE.R/L	130	80	2290	G3/4"	14	312.3	VH80..	○
SVH80 C140-L2190VE.R/L	140	80	2190	G3/4"	12	336.7	VH80..	○
SVH80 C140-L2470VE.R/L	140	80	2470	G3/4"	14	386.8	VH80..	○
SVH80 C150-L2350VE.R/L	150	80	2350	G3/4"	12	397.2	VH80..	○
SVH80 C150-L2650VE.R/L	150	80	2650	G3/4"	14	472.4	VH80..	○
SVH80 C160-L2510VE.R/L	160	80	2510	G3/4"	12	497.5	VH80..	○
SVH80 C160-L2830VE.R/L	160	80	2830	G3/4"	14	571.2	VH80..	○
SVH80 C180-L2830VE.R/L	180	80	2830	G3/4"	12	559.7	VH80..	○
SVH80 C180-L3190VE.R/L	180	80	3190	G3/4"	14	642.6	VH80..	○
SVH80 C200-L3150VE.R/L	200	80	3150	G3/4"	12	621.9	VH80..	○
SVH80 C200-L3550VE.R/L	200	80	3550	G3/4"	14	714.3	VH80..	○
SVH80 C220-L3470VE.R/L	220	80	3470	G3/4"	12	684.1	VH80..	○
SVH80 C220-L3910VE.R/L	220	80	3910	G3/4"	14	785.7	VH80..	○
SVH80 C250-L3950VE.R/L	250	80	3950	G3/4"	12	777.4	VH80..	○
SVH80 C250-L4450VE.R/L	250	80	4450	G3/4"	14	892.8	VH80..	○

- 推荐最小夹紧长度为 4xD.
- 刀杆有内冷出水孔。
- 若出现减振性能下降时, 建议维修保养。
- 订货示例: 1 件 SVH80 C100-L1560VE.
- Suggested min. Length is 4xD.
- With coolant hole.
- Suggest doing the maintenance when damping capacity is weaker than before.
- Ordering sample: 1 PC SVH80 C100-L1560VE.

## 备件

Spare Parts



D1	刀片锁紧螺钉 Clamping screw for insert	锁紧扳手 Allen key for clamping	上压板 Upper clamping pad	下压板 Lower clamping pad	压板弹簧 Spring clamping pad	定位螺钉 Clamp screw for cartridge
80	SR55 M10x25	KEY01 M8	PB20 M10x16.0	PB20 M10x11	YH 12.5x0.9x18	SR55 M3x6

- 标准库存  
Item in stock
- 半标准库存 (订货时, 请确认交货期)  
Item of short delivery time  
(please confirm delivery time when ordering it)
- 无库存 (订货时, 请确认交货期)  
Order on demand  
(please confirm delivery time when ordering it)

# DAMPING TURNING TOOL 阻尼减振车刀

## PSC 接口阻尼减振车刀杆

PSC Damping Turning Tool

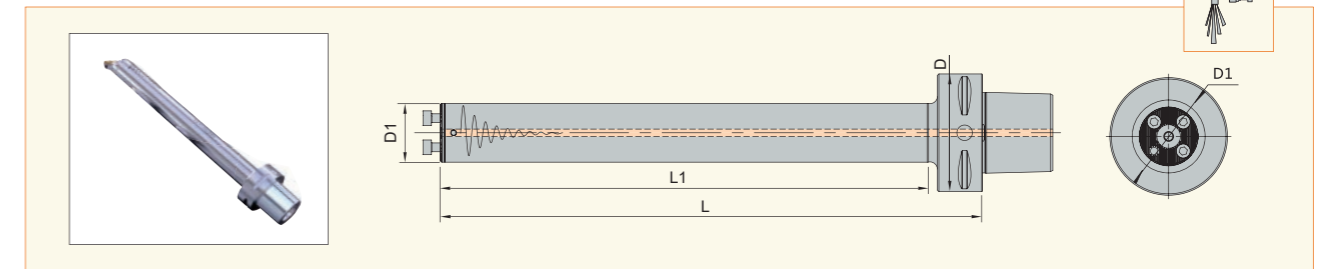

规格型号 Designation	D	D1	L	L1	L/D	Kg	适配刀头 Cartridge	在庫 Stock
C3 SAT16-L082V	32	16	82	63	5	0.25	VT16..	●
C3 SAT20-L101V	32	20	101	82	5	0.39	VT20..	●
C3 SAT25-L125V	32	25	125	107	5	0.6	VT25..	●
C3 SAT25-L180V	32	25	180	161	7	0.8	VT25..	●
C3 SAT32-L133V	32	32	133	133	5	1	VT32..	●
C3 SAT32-L224V	32	32	224	224	8	1.8	VT32..	●
C4 SAT16-L088V	40	16	88	63	5	0.4	VT16..	●
C4 SAT20-L107V	40	20	107	82	5	0.54	VT20..	●
C4 SAT25-L132V	40	25	132	108	5	0.8	VT25..	●
C4 SAT25-L180V	40	25	180	155	7	0.96	VT25..	●
C4 SAT32-L154V	40	32	154	131	5	1.29	VT32..	●
C4 SAT32-L224V	40	32	224	200	7	2.08	VT32..	●
C4 SAT40-L173V	40	40	173	173	5	1.75	VT40..	●
C4 SAT40-L288V	40	40	288	288	8	3.42	VT40..	●
C5 SAT16-L085V	50	16	85	58	5	0.63	VT16..	●
C5 SAT20-L109V	50	20	109	83	5	0.74	VT20..	●
C5 SAT25-L133V	50	25	133	107	5	1	VT25..	●
C5 SAT25-L230V	50	25	230	201	7	1.4	VT25..	●
C5 SAT32-L154V	50	32	154	129	5	1.4	VT32..	●
C5 SAT32-L288V	50	32	288	261	9	2.4	VT32..	●
C5 SAT40-L194V	50	40	194	170	5	2.24	VT40..	●
C5 SAT40-L368V	50	40	368	344	9	4.2	VT40..	●
C6 SAT16-L088V	63	16	88	58	5	1.01	VT16..	●
C6 SAT20-L108V	63	20	108	73	5	1	VT20..	●
C6 SAT25-L132V	63	25	132	103	5	1.35	VT25..	●
C6 SAT25-L230V	63	25	230	197	9	1.7	VT25..	●
C6 SAT32-L159V	63	32	159	129	5	1.8	VT32..	●
C6 SAT32-L288V	63	32	288	257	9	2.7	VT32..	●
C6 SAT40-L198V	63	40	198	169	5	2.6	VT40..	●
C6 SAT40-L368V	63	40	368	338	9	4.2	VT40..	●
C8 SAT25-L147V	80	25	147	107	5	2.3	VT25..	●
C8 SAT32-L172V	80	32	172	133	5	2.8	VT32..	●
C8 SAT32-L224V	80	32	224	184	6	3.62	VT32..	●
C8 SAT40-L224V	80	40	224	186	5	3.7	VT40..	●
C8 SAT40-L368V	80	40	368	330	9	5.4	VT40..	●

- 刀杆有内冷出水孔。
- 适配刀头需单独订购, 请参照: B11-B31 页。
- 若出现减振性能下降时, 建议维修保养。
- 订货示例: 1 件 C3 SAT16-L082V.
- With coolant hole.
- The cartridge should be ordered separately, please see page B11-B31.
- The reducing head should be ordered separately.
- Suggest doing the maintenance when damping capacity is weaker than before.
- Ordering sample: 1 PC C3 SAT16-L082V.

## 备件

Spare Parts



D1	刀头锁紧螺钉 Clamp screw for cartridge	刀头锁紧扳手 Allen key for cartridge clamping screw
16	SR55-2 M3x10	KEY01 M2.5
20	SR55-2 M3.5x10	KEY01 M2.5
25	SR55-2 M4x12	KEY01 M3
32	SR55-2 M5x12	KEY01 M4
40	SR55-2 M6x16	KEY01 M5

- 标准库存  
Item in stock
- 半标准库存 (订货时, 请确认交货期)  
Item of short delivery time  
(please confirm delivery time when ordering it)
- 无库存 (订货时, 请确认交货期)  
Order on demand  
(please confirm delivery time when ordering it)

# DAMPING TURNING TOOL 阻尼减振车刀

## PSC 接口阻尼减振车刀杆

PSC Damping Turning Tool

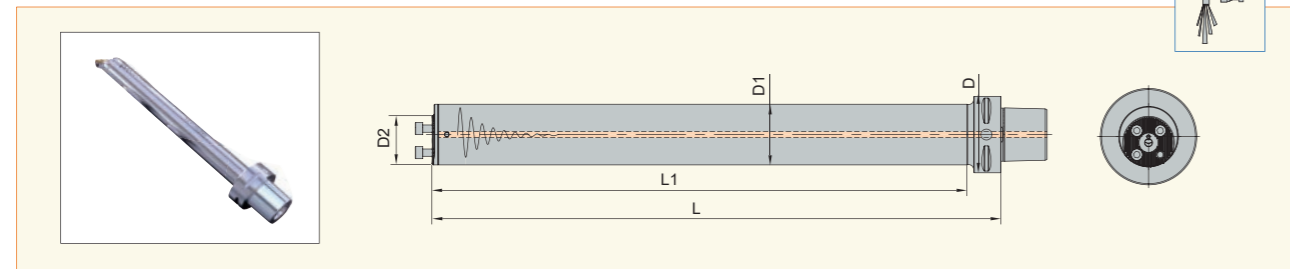

规格型号 Designation	D	D1	D2	L	L1	L/D	Kg	适配刀头 Cartridge	在庫 Stock
C5 SAT40-D50-L223V.R/L	50	50	40	223	223	5	3.6	VT40..	●
C5 SAT40-D50-L468V.R/L	50	50	40	468	468	9	10.79	VT40..	●
C6 SAT40-D50-L247V.R/L	63	50	40	247	222	5	4.2	VT40..	●
C6 SAT40-D50-L468V.R/L	63	50	40	468	440	9	7.4	VT40..	●
C6 SAT40-D60-L295V.R/L	63	60	40	295	273	5	6.8	VT40..	●
C6 SAT40-D60-L568V.R/L	63	60	40	568	545	9	12.2	VT40..	●
C8 SAT40-D50-L297V.R/L	80	50	40	297	261	5	5.8	VT40..	●
C8 SAT40-D50-L468V.R/L	80	50	40	468	434	9	8.3	VT40..	●
C8 SAT40-D60-L355V.R/L	80	60	40	355	320	5	8.9	VT40..	●
C8 SAT40-D60-L568V.R/L	80	60	40	568	531	9	13	VT40..	●

- 刀杆有内冷出水孔。
- 适配刀头需单独订购，请参照：☐ B11-B31 页。
- 若出现减振性能下降时，建议维修保养。
- 订货示例：1 件 C5 SAT40-D50-L223V.R/L。
- With coolant hole.
- The cartridge should be ordered separately, please see page B11-B31.
- Suggest doing the maintenance when damping capacity is weaker than before.
- Ordering sample: 1 PC C5 SAT40-D50-L223V.R/L.

## 备件

Spare Parts

D1	刀头锁紧螺钉 Clamp screw for cartridge	刀头锁紧扳手 Allen key for cartridge clamping screw
16	SR55-2 M3x10	KEY01 M2.5
20	SR55-2 M3.5x10	KEY01 M2.5
25	SR55-2 M4x12	KEY01 M3
32	SR55-2 M5x12	KEY01 M4
40	SR55-2 M6x16	KEY01 M5

● 标准库存  
Item in stock

◐ 半标准库存 (订货时，请确认交货期)  
Item of short delivery time  
(please confirm delivery time when ordering it)

○ 无库存 (订货时，请确认交货期)  
Order on demand  
(please confirm delivery time when ordering it)

# DAMPING TURNING TOOL 阻尼减振车刀

## HSK 减振车刀杆

Damping Turning Tool with HSK Holder

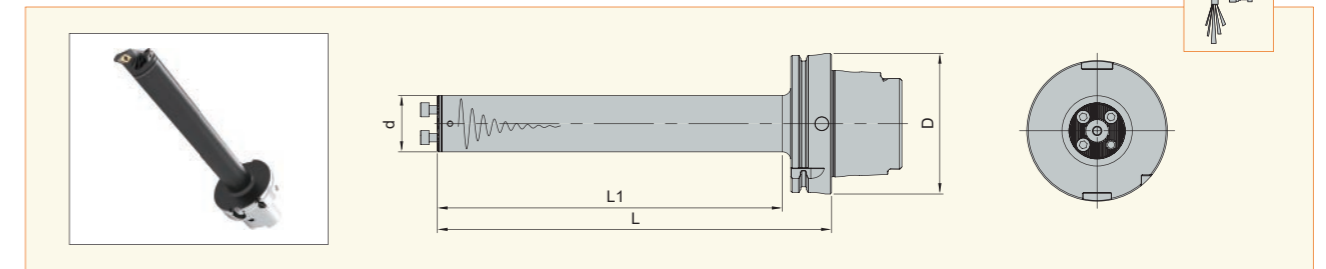

规格型号 Designation	D	d	L1	L	L/D	Bar	Kg	在庫 Stock
HSK ST63 VT32-L172.V	63.0	32.0	143.0	172.0	5	70	1.8	●
HSK ST63 VT40-L208.V	63.0	40.0	179.0	208.0	5	70	2.7	●
HSK ST100 VT40-L208.V	100.0	40.0	176.0	208.0	5	70	4.0	●

- 刀杆有内冷出水孔。
- 适配刀头需单独订购，请参照：☐ B11-B31 页。
- 若出现减振性能下降时，建议维修保养。
- 订货示例：1 件 HSK ST63 VT32-L172.V。
- With coolant hole.
- The cartridge should be ordered separately, please see page B11-B31.
- Suggest doing the maintenance when damping capacity is weaker than before.
- Ordering sample: 1 PC HSK ST63 VT32-L172.V.

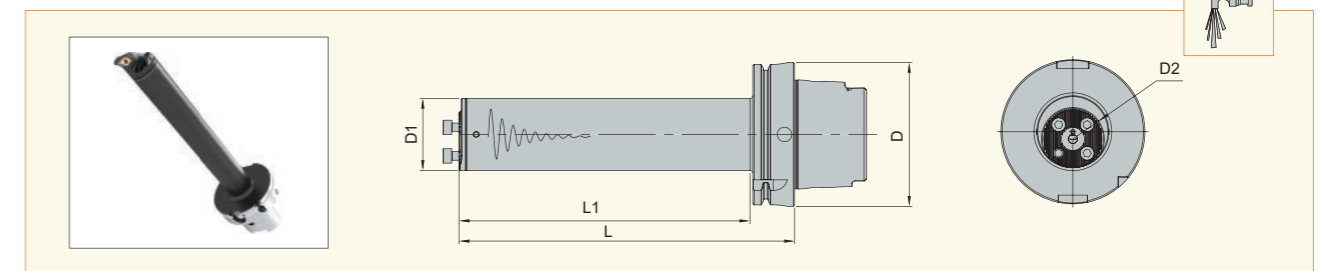

规格型号 Designation	D	D1	D2	L1	L	L/D	Bar	Kg	在庫 Stock
HSK ST63 VT40-D50-L268.V	63.0	50.0	40.0	239.0	268.0	5	70	4.6	●
HSK ST100 VT40-D50-L268.V	100.0	50.0	40.0	236.0	268.0	5	70	5.8	●
HSK ST100 VT40-D60-L328.V	100.0	60.0	40.0	296.0	328.0	5	70	8.7	●

- 刀杆有内冷出水孔。
- 适配刀头需单独订购，请参照：☐ B11-B31 页。
- 若出现减振性能下降时，建议维修保养。
- 订货示例：1 件 HSK ST63 VT40-D50-L268.V。
- With coolant hole.
- The cartridge should be ordered separately, please see page B11-B31.
- Suggest doing the maintenance when damping capacity is weaker than before.
- Ordering sample: 1 PC HSK ST63 VT40-D50-L268.V.

● 标准库存  
Item in stock

◐ 半标准库存 (订货时，请确认交货期)  
Item of short delivery time  
(please confirm delivery time when ordering it)

○ 无库存 (订货时，请确认交货期)  
Order on demand  
(please confirm delivery time when ordering it)

# DAMPING TURNING TOOL 阻尼减振车刀

## 阻尼减振车刀刀头

Cartridge for Damping Turning Tool Holder

### 正型 95° 正镗

Positive Type 95° Boring

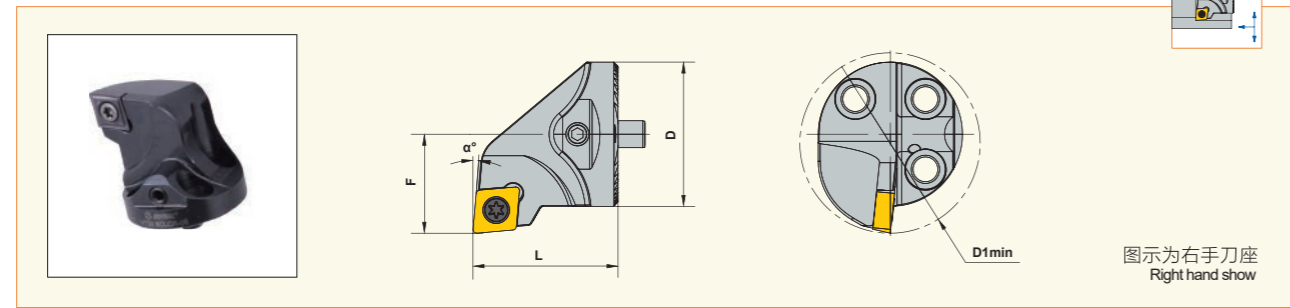

规格型号 Designation	D	D1 min	F	L	α°	Kg	适配刀片 Insert	在庫 Stock
SVT16 SCLCR-06	16	20	11	20	5°	0.02	CC..0602..	●
SVT20 SCLCR-09	20	25	13	20	5°	0.03	CC..09T3..	●
SVT25 SCLCR-09	25	32	17	20	5°	0.04	CC..09T3..	●
SVT32 SCLCR-09	32	40	22	32	5°	0.1	CC..09T3..	●
SVT40 SCLCR-12T	40	50	27	38	5°	0.2	CC..1204..	●
SVT16 SCLCL-06	16	20	11	20	5°	0.02	CC..0602..	●
SVT20 SCLCL-09	20	25	13	20	5°	0.03	CC..09T3..	●
SVT25 SCLCL-09	25	32	17	20	5°	0.04	CC..09T3..	●
SVT32 SCLCL-09	32	40	22	32	5°	0.1	CC..09T3..	●
SVT40 SCLCL-12T	40	50	27	38	5°	0.2	CC..1204..	●

- 刀片请根据不同材料单独订购,
- 订货示例: 1件 SVT16 SCLCR-06.
- The insert should be ordered separately.
- Ordering sample: 1 PC SVT16 SCLCR-06.

### 备件

Spare Parts

规格型号 Designation	刀片锁紧螺钉 Clamping screw for insert	锁紧扳手 Allen key for clamping	刀垫 Shim	刀垫螺套 Sleeve for shim	刀垫扳手 Allen key for shim	定位销 Locating pin
SVT16 ...-06	SR21 M2.5x5.3	KEY03 T7	-	-	-	FT39 D4-3x7
SVT20 ...-09	SR21 M4x9.5	KEY03 T15	-	-	-	FT39 D6-5x8
SVT25 ...-09	SR21 M4x9.5	KEY03 T15	-	-	-	FT39 D6-5x9
SVT32 ...-09	SR21 M4x9.5	KEY03 T15	-	-	-	FT39 D6-5x11
SVT40 ...-12T	SR21 M5x12.8	KEY03 T20	ST01 CC12x2.8	SRT M7-M5x13	KEY01 M3	FT39 D6-5x11

- 标准库存  
Item in stock
- 半标准库存 (订货时, 请确认交货期)  
Item of short delivery time  
(please confirm delivery time when ordering it)
- 无库存 (订货时, 请确认交货期)  
Order on demand  
(please confirm delivery time when ordering it)

# DAMPING TURNING TOOL 阻尼减振车刀

## 阻尼减振车刀刀头

Cartridge for Damping Turning Tool Holder

### 正型 93° 正镗

Positive Type 93° Boring

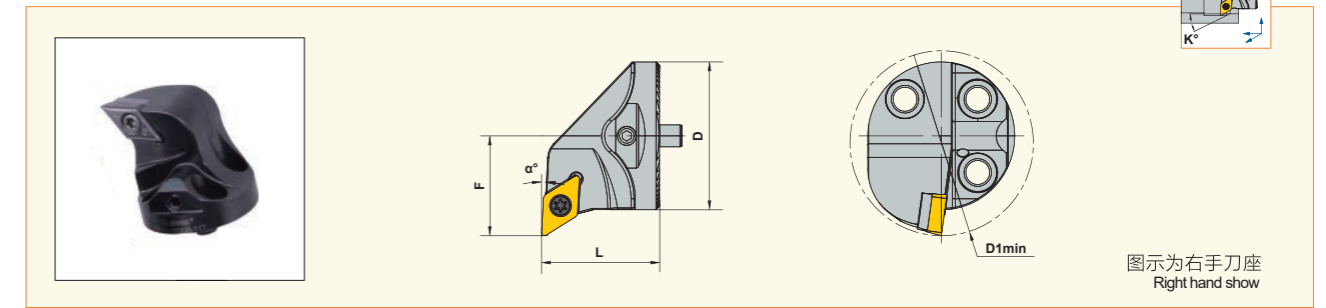

规格型号 Designation	D	D1 min	F	L	α°	K°	Kg	适配刀片 Insert	在庫 Stock
SVT16 SDUCR-07	16	20	11	20	3°	27°	0.02	DC..0702..	●
SVT20 SDUCR-11	20	25	13	20	3°	27°	0.03	DC..11T3..	●
SVT25 SDUCR-11	25	32	17	20	3°	27°	0.04	DC..11T3..	●
SVT32 SDUCR-11T	32	40	22	32	3°	27°	0.1	DC..11T3..	●
SVT40 SDUCR-11T	40	50	27	32	3°	27°	0.2	DC..11T3..	●
SVT16 SDUCL-07	16	20	11	20	3°	27°	0.02	DC..0702..	●
SVT20 SDUCL-11	20	25	13	20	3°	27°	0.03	DC..11T3..	●
SVT25 SDUCL-11	25	32	17	20	3°	27°	0.04	DC..11T3..	●
SVT32 SDUCL-11T	32	40	22	32	3°	27°	0.1	DC..11T3..	●
SVT40 SDUCL-11T	40	50	27	32	3°	27°	0.2	DC..11T3..	●

- 刀片请根据不同材料单独订购,
- 订货示例: 1件 SVT16 SDUCR-07.
- The insert should be ordered separately.
- Ordering sample: 1 PC SVT16 SDUCR-07.

### 备件

Spare Parts

规格型号 Designation	刀片锁紧螺钉 Clamping screw for insert	锁紧扳手 Allen key for clamping	刀垫 Shim	刀垫螺套 Sleeve for shim	刀垫扳手 Allen key for shim	定位销 Locating pin
SVT16 ...-07	SR21 M2.5x5.3	KEY03 T7	-	-	-	FT39 D4-3x7
SVT20 ...-11	SR21 M4x11	KEY03 T15	-	-	-	FT39 D6-5x8
SVT25 ...-11	SR21 M4x11	KEY03 T15	-	-	-	FT39 D6-5x9
SVT32 ...-11T	SR21 M4x11	KEY03 T15	ST01 DC11x2.82	SRT M6-M4x6.9	KEY01 M4	FT39 D6-5x11
SVT40 ...-11T	SR21 M4x11	KEY03 T15	ST01 DC11x2.82	SRT M6-M4x6.9	KEY01 M4	FT39 D6-5x11

- 标准库存  
Item in stock
- 半标准库存 (订货时, 请确认交货期)  
Item of short delivery time  
(please confirm delivery time when ordering it)
- 无库存 (订货时, 请确认交货期)  
Order on demand  
(please confirm delivery time when ordering it)

# DAMPING TURNING TOOL 阻尼减振车刀

## 阻尼减振车刀刀头

Cartridge for Damping Turning Tool Holder

### 正型 93° 正镗及仿形车

Positive Type 93° Boring and Profile-turning

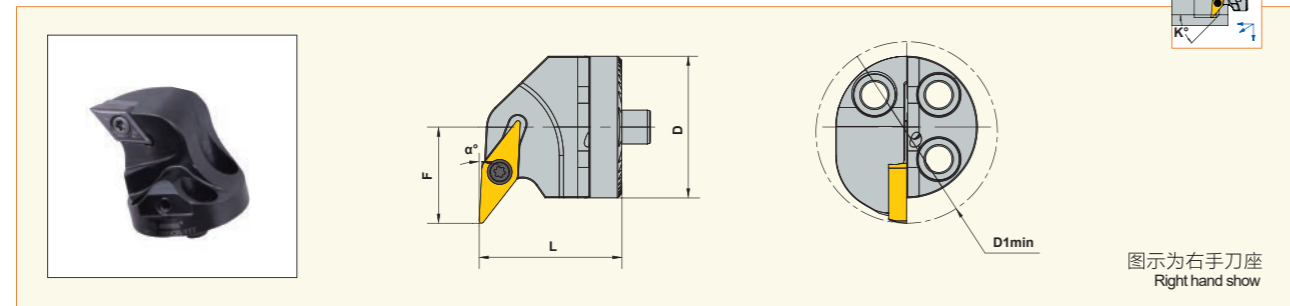

规格型号 Designation	D	D1 min	F	L	$\alpha^\circ$	$K^\circ$	Kg	适配刀片 Insert	在庫 Stock
SVT20 SVUCR-11	20	27	16	20	3°	50°	0.02	VC..1103..	●
SVT25 SVUCR-11	25	31	17	25	3°	50°	0.04	VC..1103..	●
SVT20 SVUCL-11	20	27	16	20	3°	50°	0.02	VC..1103..	○
SVT25 SVUCL-11	25	31	17	25	3°	50°	0.04	VC..1103..	○

- 刀片请根据不同材料单独订购。
- 订货示例：1 件 SVT20 SVUCR-11。
- The insert should be ordered separately.
- Ordering sample: 1 PC SVT20 SVUCR-11.

## 备件

Spare Parts



规格型号 Designation	刀片锁紧螺钉 Clamping screw for insert	锁紧扳手 Allen key for clamping	定位销 Locating pin
SVT20 ...-11	SR20 M2.5x6	KEY03 T8	FT39 D6-5x8
SVT25 ...-11	SR20 M2.5x6	KEY03 T8	FT39 D6-5x9

● 标准库存  
Item in stock

● 半标准库存 (订货时, 请确认交货期)  
Item of short delivery time  
(please confirm delivery time when ordering it)

○ 无库存 (订货时, 请确认交货期)  
Order on demand  
(please confirm delivery time when ordering it)

# DAMPING TURNING TOOL 阻尼减振车刀

## 阻尼减振车刀刀头

Cartridge for Damping Turning Tool Holder

### 正型 95° 正镗及仿形车

Positive Type 95° Boring and Profile-turning

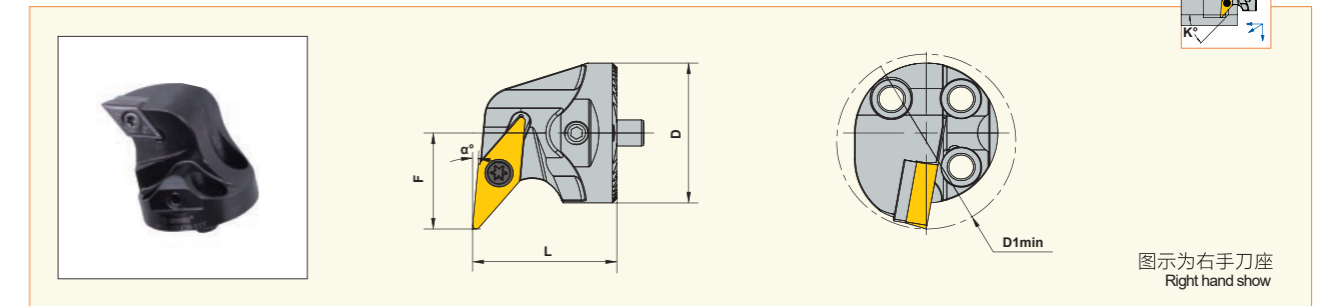

规格型号 Designation	D	D1 min	F	L	$\alpha^\circ$	$K^\circ$	Kg	适配刀片 Insert	在庫 Stock
SVT32 SVLCR-16T	32	40	22	32	5°	45°	0.1	VC..1604..	●
SVT40 SVLCR-16T	40	50	27	32	5°	45°	0.15	VC..1604..	●
SVT32 SVLCL-16T	32	40	22	32	5°	45°	0.1	VC..1604..	○
SVT40 SVLCL-16T	40	50	27	32	5°	45°	0.15	VC..1604..	○

- 刀片请根据不同材料单独订购。
- 订货示例：1 件 SVT32 SVLCR-16T。
- The insert should be ordered separately.
- Ordering sample: 1 PC SVT32 SVLCR-16T.

## 备件

Spare Parts



规格型号 Designation	刀片锁紧螺钉 Clamping screw for insert	锁紧扳手 Allen key for clamping	刀垫 Shim	刀垫螺套 Sleeve for shim	刀垫扳手 Allen key for shim	定位销 Locating pin
SVT32 ...-16T	SR21 M4x11	KEY03 T15	ST01 VC16x2.82	SRT M6-M4x6.9	KEY01 M4	FT39 D6-5x11
SVT40 ...-16T	SR21 M4x11	KEY03 T15	ST01 VC16x2.82	SRT M6-M4x6.9	KEY01 M4	FT39 D6-5x11

● 标准库存  
Item in stock

● 半标准库存 (订货时, 请确认交货期)  
Item of short delivery time  
(please confirm delivery time when ordering it)

○ 无库存 (订货时, 请确认交货期)  
Order on demand  
(please confirm delivery time when ordering it)

# DAMPING TURNING TOOL 阻尼减振车刀

## 阻尼减振车刀刀头

Cartridge for Damping Turning Tool Holder

### 正型 62.5° 仿形车

Positive Type 62.5° Profile-turning

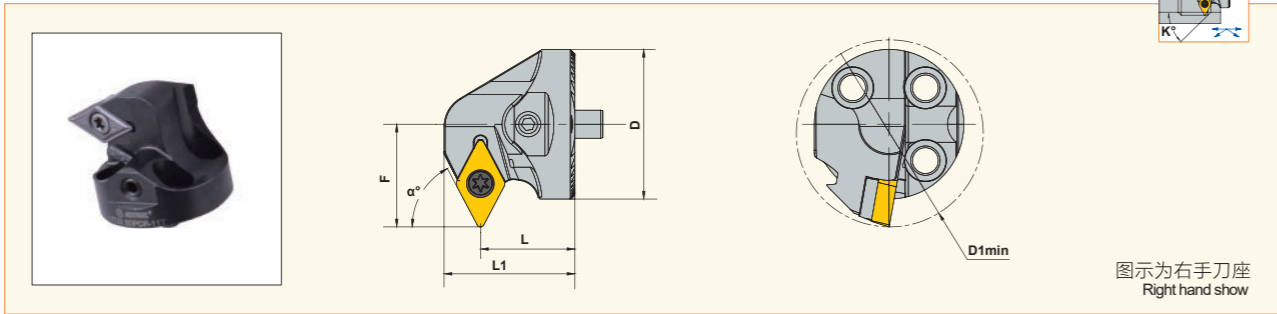

图示为右手刀座  
Right hand show

规格型号 Designation	D	D1 min	F	L	L1	α°	K°	Kg	适配刀片 Insert	在庫 Stock
SVT16 SDPCR-07	16	22	13	15	19	62.5°	60°	0.01	DC..0702..	●
SVT20 SDPCR-07	20	27	15	15	19	62.5°	60°	0.02	DC..0702..	●
SVT25 SDPCR-07	25	33	18	15	19	62.5°	60°	0.03	DC..0702..	●
SVT32 SDPCR-11T	32	40	22	20	28	62.5°	60°	0.09	DC..11T3..	●
SVT40 SDPCR-11T	40	50	27	20	28	62.5°	60°	0.14	DC..11T3..	●
SVT16 SDPCL-07	16	22	13	15	19	62.5°	60°	0.01	DC..0702..	●
SVT20 SDPCL-07	20	27	15	15	19	62.5°	60°	0.02	DC..0702..	●
SVT25 SDPCL-07	25	33	18	15	19	62.5°	60°	0.03	DC..0702..	●
SVT32 SDPCL-11T	32	40	22	20	28	62.5°	60°	0.09	DC..11T3..	●
SVT40 SDPCL-11T	40	50	27	20	28	62.5°	60°	0.14	DC..11T3..	●

- 刀片请根据不同材料单独订购。
- 订货示例：1 件 SVT16 SDPCR-07。
- The insert should be ordered separately.
- Ordering sample: 1 PC SVT16 SDZCR-07.

## 备件

Spare Parts



规格型号 Designation	刀片锁紧螺钉 Clamping screw for insert	锁紧扳手 Allen key for clamping	刀垫 Shim	刀垫螺套 Sleeve for shim	刀垫扳手 Allen key for shim	定位销 Locating pin
SVT16 ...-07	SR21 M2.5x5.3	KEY03 T7	-	-	-	FT39 D4-3x7
SVT20 ...-07	SR21 M2.5x5.3	KEY03 T7	-	-	-	FT39 D6-5x8
SVT25 ...-07	SR21 M2.5x5.3	KEY03 T7	-	-	-	FT39 D6-5x9
SVT32 ...-11T	SR21 M4x11	KEY03 T15	ST01 DC11x2.82	SRT M6-M4x6.9	KEY01 M4	FT39 D6-5x11
SVT40 ...-11T	SR21 M4x11	KEY03 T15	ST01 DC11x2.82	SRT M6-M4x6.9	KEY01 M4	FT39 D6-5x11

- 标准库存  
Item in stock
- 半标准库存 (订货时, 请确认交货期)  
Item of short delivery time  
(please confirm delivery time when ordering it)
- 无库存 (订货时, 请确认交货期)  
Order on demand  
(please confirm delivery time when ordering it)

# DAMPING TURNING TOOL 阻尼减振车刀

## 阻尼减振车刀刀头

Cartridge for Damping Turning Tool Holder

### 正型 93° 反镗

Positive Type 93° Back Boring

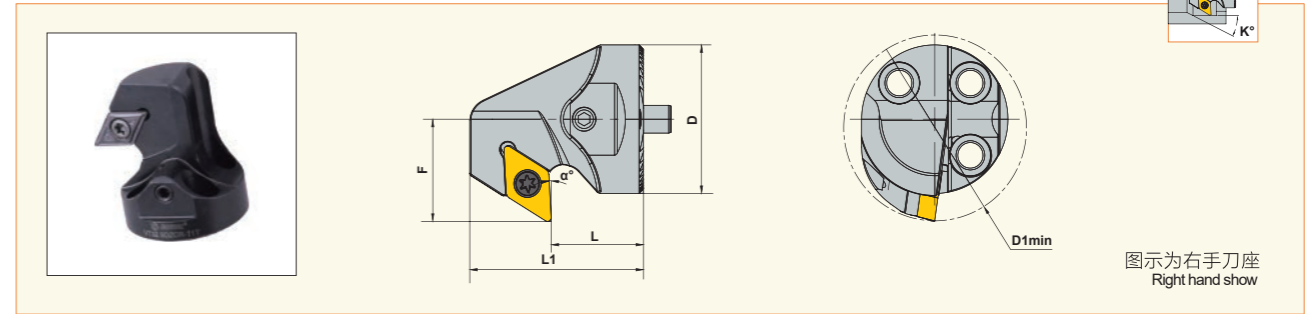
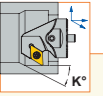

图示为右手刀座  
Right hand show

规格型号 Designation	D	D1 min	F	L	L1	α°	K°	Kg	适配刀片 Insert	在庫 Stock
SVT16 SDZCR-07	16	22	13	15	27	3°	27°	0.03	DC..0702..	●
SVT20 SDZCR-07	20	27	15	15	27	3°	27°	0.05	DC..0702..	●
SVT25 SDZCR-07	25	33	18	15	27	3°	27°	0.12	DC..0702..	●
SVT32 SDZCR-11T	32	40	22	20	38	3°	27°	0.14	DC..11T3..	●
SVT40 SDZCR-11T	40	50	27	20	38	3°	27°	0.19	DC..11T3..	●
SVT16 SDZCL-07	16	22	13	15	27	3°	27°	0.03	DC..0702..	●
SVT20 SDZCL-07	20	27	15	15	27	3°	27°	0.05	DC..0702..	●
SVT25 SDZCL-07	25	33	18	15	27	3°	27°	0.12	DC..0702..	●
SVT32 SDZCL-11T	32	40	22	20	38	3°	27°	0.14	DC..11T3..	●
SVT40 SDZCL-11T	40	50	27	20	38	3°	27°	0.19	DC..11T3..	●

- 刀片请根据不同材料单独订购。
- 订货示例：1 件 SVT16 SDZCR-07。
- The insert should be ordered separately.
- Ordering sample: 1 PC SVT16 SDZCR-07.

## 备件

Spare Parts



规格型号 Designation	刀片锁紧螺钉 Clamping screw for insert	锁紧扳手 Allen key for clamping	刀垫 Shim	刀垫螺套 Sleeve for shim	刀垫扳手 Allen key for shim	定位销 Locating pin
SVT16 ...-07	SR21 M2.5x5.3	KEY03 T7	-	-	-	FT39 D4-3x7
SVT20 ...-07	SR21 M2.5x5.3	KEY03 T7	-	-	-	FT39 D6-5x8
SVT25 ...-07	SR21 M2.5x5.3	KEY03 T7	-	-	-	FT39 D6-5x9
SVT32 ...-11T	SR21 M4x11	KEY03 T15	ST01 DC11x2.82	SRT M6-M4x6.9	KEY01 M4	FT39 D6-5x11
SVT40 ...-11T	SR21 M4x11	KEY03 T15	ST01 DC11x2.82	SRT M6-M4x6.9	KEY01 M4	FT39 D6-5x11

- 标准库存  
Item in stock
- 半标准库存 (订货时, 请确认交货期)  
Item of short delivery time  
(please confirm delivery time when ordering it)
- 无库存 (订货时, 请确认交货期)  
Order on demand  
(please confirm delivery time when ordering it)

# DAMPING TURNING TOOL 阻尼减振车刀

## 阻尼减振车刀刀头

Cartridge for Damping Turning Tool Holder

### 正型 91° 正镗

Positive Type 91° Profile-turning

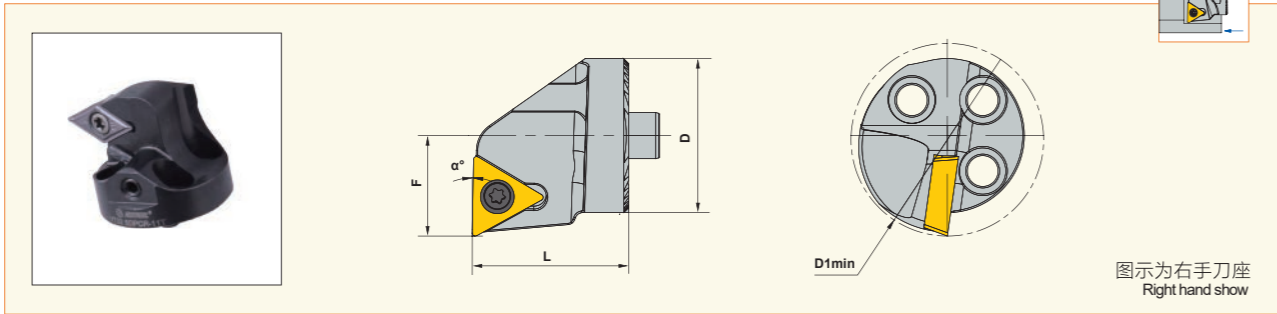

规格型号 Designation	D	D1 min	F	L	α°	Kg	适配刀片 Insert	在庫 Stock
SVT16 STFCR-09	16	20	11	20	1°	0.02	TC..0902..	●
SVT16 STFCR-11	16	20	11	20	1°	0.02	TC..1102..	●
SVT20 STFCR-11	20	25	13	20	1°	0.03	TC..1102..	●
SVT25 STFCR-11	25	32	17	20	1°	0.04	TC..1102..	●
SVT32 STFCR-16	32	40	22	32	1°	0.10	TC..16T3..	●
SVT40 STFCR-16	40	50	27	32	1°	0.20	TC..16T3..	●
SVT16 STFCL-09	16	20	11	20	1°	0.02	TC..0902..	●
SVT16 STFCL-11	16	20	11	20	1°	0.02	TC..1102..	●
SVT20 STFCL-11	20	25	13	20	1°	0.03	TC..1102..	●
SVT25 STFCL-11	25	32	17	20	1°	0.04	TC..1102..	●
SVT32 STFCL-16	32	40	22	32	1°	0.10	TC..16T3..	●
SVT40 STFCL-16	40	50	27	32	1°	0.20	TC..16T3..	●

- 刀片请根据不同材料单独订购。
- 订货示例：1 件 SVT16 STFCR-09。
- The insert should be ordered separately.
- Ordering sample: 1 PC SVT16 STFCR-09.

## 备件

Spare Parts

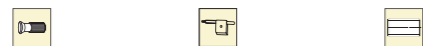

规格型号 Designation	刀片锁紧螺钉 Clamping screw for insert	锁紧扳手 Allen key for clamping	定位销 Locating pin
SVT16...09	SR20 M2.2x5.6	KEY03 T7	FT39 D4-3x7
SVT16...11	SR20 M2.5x6	KEY03 T8	FT39 D4-3x7
SVT20...11	SR20 M2.5x6	KEY03 T8	FT39 D6-5x8
SVT25...11	SR20 M2.5x6	KEY03 T8	FT39 D6-5x9
SVT32...16	SR21 M4x9.5	KEY03 T15	FT39 D6-5x11
SVT40...16	SR21 M4x9.5	KEY03 T15	FT39 D6-5x11

- 标准库存  
Item in stock
- 半标准库存 (订货时, 请确认交货期)  
Item of short delivery time  
(please confirm delivery time when ordering it)
- 无库存 (订货时, 请确认交货期)  
Order on demand  
(please confirm delivery time when ordering it)

# DAMPING TURNING TOOL 阻尼减振车刀

## 阻尼减振车刀刀头

Cartridge for Damping Turning Tool Holder

### 负型 95° 正镗

Negative Type 95° Profile-turning

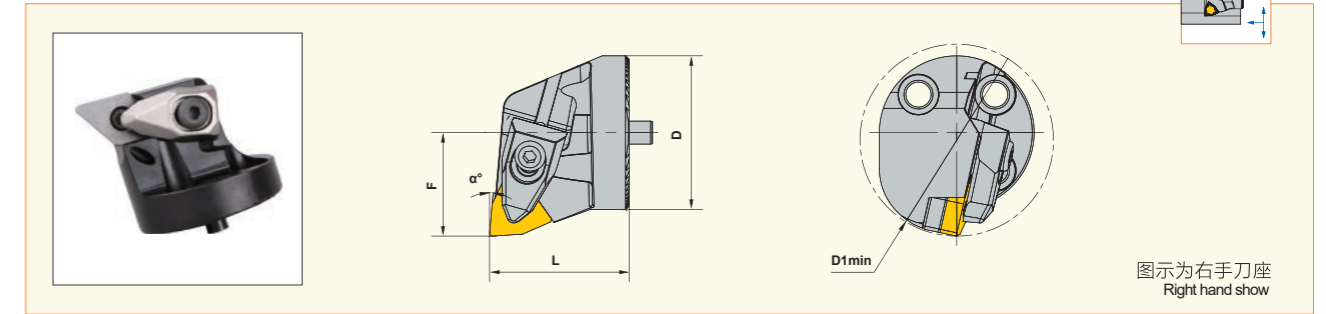

规格型号 Designation	D	D1 min	F	L	α°	Kg	适配刀片 Insert	在庫 Stock
SVT32 DWLNR-06T	32	40	22	32	5°	0.11	WN..0604..	●
SVT32 DWLNR-08T	32	46	24	36	5°	0.12	WN..0804..	●
SVT40 DWLNR-08T	40	50	27	36	5°	0.23	WN..0804..	●
SVT32 DWLNL-06T	32	40	22	32	5°	0.11	WN..0604..	●
SVT32 DWLNL-08T	32	46	24	36	5°	0.12	WN..0804..	●
SVT40 DWLNL-08T	40	50	27	36	5°	0.23	WN..0804..	●

- 刀片请根据不同材料单独订购。
- 订货示例：1 件 SVT32 DWLNR-06T。
- The insert should be ordered separately.
- Ordering sample: 1 PC SVT32 DWLNR-06T.

## 备件

Spare Parts

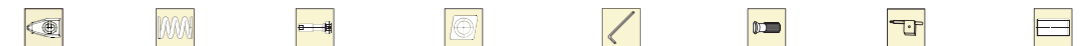

规格型号 Designation	压板 Clamping pad	压板弹簧 Spring for clamping pad	压板螺钉 Screw for clamping pad	刀垫 Shim	压板扳手 Allen key for clamping pad	刀垫锁紧螺钉 Clamping screw for shim	刀垫锁紧扳手 Allen key for shim	定位销 Locating pin
SVT32...06T	PB10 DDN11	YH 7x0.6x13	SR59 M4x16	ST01 WN06x3.18	KEY01 M2.5	SR20 M4x9.5	KEY03 T15	FT39 D6-5x11
SVT32...08T	PB10 DCN12	YH 8x0.6x13	SR59 M5x20	ST01 WN08x3.18	KEY01 M3	SR20 M5x10	KEY03 T20	FT39 D6-5x11
SVT40...08T	PB10 DCN12	YH 8x0.6x13	SR59 M5x20	ST01 WN08x3.18	KEY01 M3	SR20 M5x10	KEY03 T20	FT39 D6-5x11

- 标准库存  
Item in stock
- 半标准库存 (订货时, 请确认交货期)  
Item of short delivery time  
(please confirm delivery time when ordering it)
- 无库存 (订货时, 请确认交货期)  
Order on demand  
(please confirm delivery time when ordering it)

# DAMPING TURNING TOOL 阻尼减振车刀

## 阻尼减振车刀刀头

Cartridge for Damping Turning Tool Holder

### 正型 93° 反镗及仿形车

Positive Type 93° Back Boring and Profile-turning

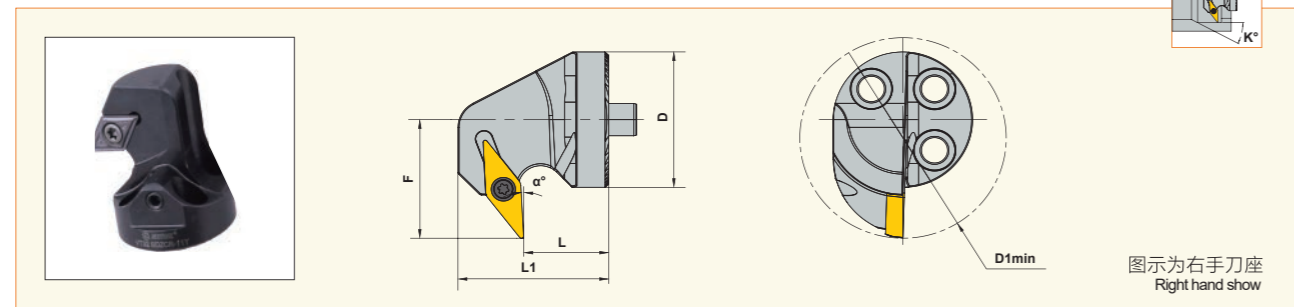

规格型号 Designation	D	D1 min	F	L	L1	α°	K°	KG	适配刀片 Insert	在庫 Stock
SVT20 SVZCR-11	20	32	20	15	27	3°	45°	0.03	VC.. 1103..	●
SVT25 SVZCR-11	25	37	22	15	27	3°	45°	0.05	VC.. 1103..	●
SVT20 SVZCL-11	20	32	20	15	27	3°	45°	0.03	VC.. 1103..	●
SVT25 SVZCL-11	25	37	22	15	27	3°	45°	0.05	VC.. 1103..	●

- 刀片请根据不同材料单独订购。
- 订货示例: 1 件 SVT20 SVZCR-11。
- The insert should be ordered separately.
- Ordering sample: 1 PC SVT20 SVZCR-11.

## 备件

Spare Parts



规格型号 Designation	刀片锁紧螺钉 Clamping screw for insert	锁紧扳手 Allen key for clamping	定位销 Locating pin
SVT20 ...-11	SR20 M2.5x6	KEY03 T8	FT39 D6-5x8
SVT25 ...-11	SR20 M2.5x6	KEY03 T8	FT39 D6-5x9

● 标准库存  
Item in stock

● 半标准库存 (订货时, 请确认交货期)  
Item of short delivery time  
(please confirm delivery time when ordering it)

○ 无库存 (订货时, 请确认交货期)  
Order on demand  
(please confirm delivery time when ordering it)

# DAMPING TURNING TOOL 阻尼减振车刀

## 阻尼减振车刀刀头

Cartridge for Damping Turning Tool Holder

### 负型 95° 正镗

Negative Type 95° Boring

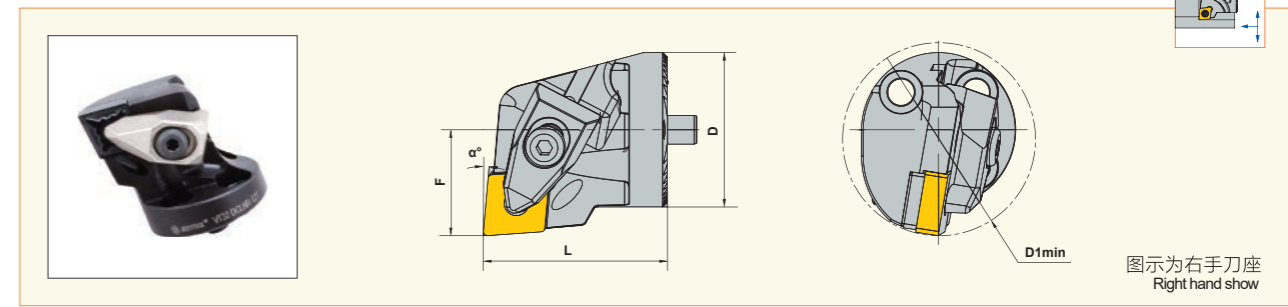

规格型号 Designation	D	D1 min	F	L	α°	kg	适配刀片 Insert	在庫 Stock
SVT32 DCLNR-12T	32	40	22	38	5°	0.12	CN.. 1204..	●
SVT40 DCLNR-12T	40	50	27	38	5°	0.21	CN.. 1204..	●
SVT32 DCLNL-12T	32	40	22	38	5°	0.12	CN.. 1204..	●
SVT40 DCLNL-12T	40	50	27	38	5°	0.21	CN.. 1204..	●

- 刀片请根据不同材料单独订购。
- 订货示例: 1 件 SVT32 DCLNR-12T。
- The insert should be ordered separately.
- Ordering sample: 1 PC SVT32 DCLNR-12T.

## 备件

Spare Parts



规格型号 Designation	压板 Clamping pad	压板弹簧 Spring for clamping pad	压板螺钉 Screw for clamping pad	刀垫 Shim	压板扳手 Allen key for clamping pad	刀垫锁紧螺钉 Clamping screw for shim	刀垫锁紧扳手 Allen key for shim	定位销 Locating pin
SVT32 ...-12T	PB10 DCN12	YH 8x0.6x13	SR59 M5x20	ST01 CN12x3.2	KEY01 M3	SR20 M5x10	KEY03 T20	FT39 D6-5x11
SVT40 ...-12T	PB10 DCN12	YH 8x0.6x13	SR59 M5x20	ST01 CN12x3.2	KEY01 M3	SR20 M5x10	KEY03 T20	FT39 D6-5x11

● 标准库存  
Item in stock

● 半标准库存 (订货时, 请确认交货期)  
Item of short delivery time  
(please confirm delivery time when ordering it)

○ 无库存 (订货时, 请确认交货期)  
Order on demand  
(please confirm delivery time when ordering it)

# DAMPING TURNING TOOL 阻尼减振车刀

## 阻尼减振车刀刀头

Cartridge for Damping Turning Tool Holder

### 负型 93° 正镗及仿形车

Negative Type 95° Boring and Profile-turning

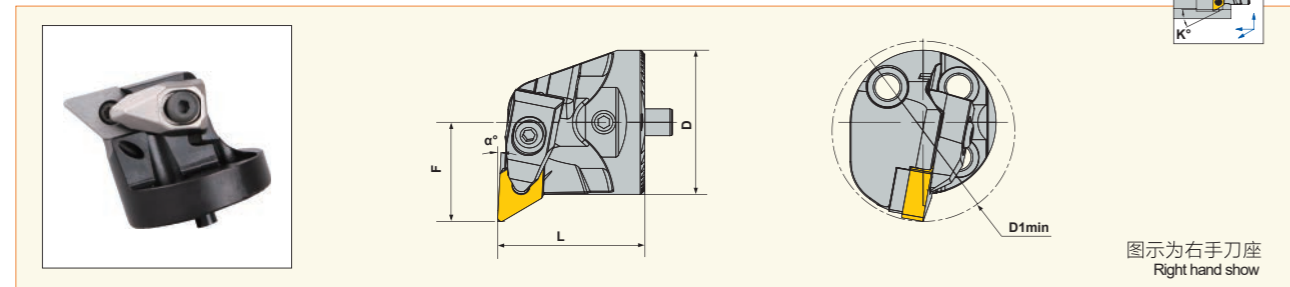

规格型号 Designation	D	D1 min	F	L	α°	K°	Kg	适配刀片 Insert	在庫 Stock
SVT32 DDUNL-11T	32	40	22	32	3°	27°	0.11	DN.. 1104..	○
SVT40 DDUNL-15T	40	50	27	38	3°	27°	0.18	DN.. 1506..	○
SVT32 DDUNR-11T	32	40	22	32	3°	27°	0.11	DN.. 1104..	○
SVT40 DDUNR-15T	40	50	27	38	3°	27°	0.18	DN.. 1506..	○
SVT40 DVUNR-16T	40	56	34	38	3°	25°	0.2	VN.. 1604..	○
SVT40 DVUNL-16T	40	56	34	38	3°	25°	0.2	VN.. 1604..	○

- 刀片请根据不同材料单独订购。
- 订货示例：1 件 SVT32 DDUNL-11T。
- The insert should be ordered separately.
- Ordering sample: 1 PC SVT32 DDUNL-11T.

## 备件

Spare Parts



规格型号 Designation	压板 Clamping pad	压板弹簧 Spring for clamping pad	压板螺钉 Screw for clamping pad	刀垫 Shim	压板扳手 Allen key for clamping pad	刀垫锁紧螺钉 Clamping screw for shim	刀垫锁紧扳手 Allen key for shim	定位销 Locating pin
SVT32 ...-11T	PB10 DDN11	YH 7x0.6x13	SR59 M4x16	ST01 DN11x3.18	KEY01 M2.5	SR21 M4x9.5	KEY03 T15	FT39 D6-5x11
SVT40 ...-15T	PB10 DCN12	YH 8x0.6x13	SR59 M5x20	ST01 DN15x4.76	KEY01 M3	SR20 M4x11.5	KEY03 T15	FT39 D6-5x11
SVT40 ...-16T	PB10 DVN16	YH 9x0.8x14	SR59 M6x26.5	ST01 VN16x3.2	KEY01 M4	SR20 M3.5x8.5	KEY03 T10	FT39 D6-5x11

- 标准库存  
Item in stock
- 半标准库存 (订货时, 请确认交货期)  
Item of short delivery time  
(please confirm delivery time when ordering it)
- 无库存 (订货时, 请确认交货期)  
Order on demand  
(please confirm delivery time when ordering it)

# DAMPING TURNING TOOL 阻尼减振车刀

## 阻尼减振车刀刀头

Cartridge for Damping Turning Tool Holder

### 正型 95° 正镗

Positive Type 95° Profile-turning

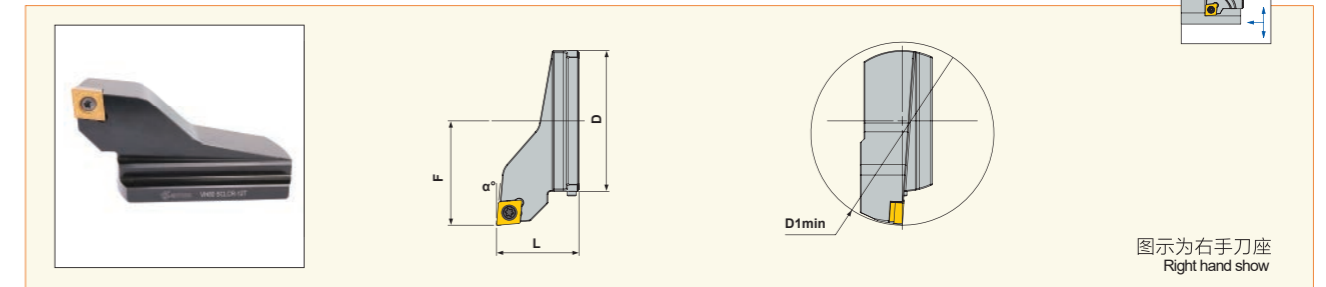

规格型号 Designation	D	D1 min	F	L	α°	Kg	适配刀片 Insert	在庫 Stock
SVH80 SCLCR-12T	80	100	57	45	5°	0.5	CC.. 1204..	●
SVH80 SCLCL-12T	80	100	57	45	5°	0.5	CC.. 1204..	●

- 刀片请根据不同材料单独订购。
- 订货示例：1 件 SVH80 SCLCR-12T。
- The insert should be ordered separately.
- Ordering sample: 1 PC SVH80 SCLCR-12T.

## 备件

Spare Parts

规格型号 Designation	刀片锁紧螺钉 Clamping screw for shim	锁紧扳手 Allen key for shim	刀垫 Shim	刀垫螺套 Insert socket for knife	刀垫扳手 Allen key for shim
SVH80...-12T	SR21 M5X12.8	KEY03 T20	ST01 CC12X2.8	SRT M7-M5X13	KEY01 M3

- 标准库存  
Item in stock
- 半标准库存 (订货时, 请确认交货期)  
Item of short delivery time  
(please confirm delivery time when ordering it)
- 无库存 (订货时, 请确认交货期)  
Order on demand  
(please confirm delivery time when ordering it)

# DAMPING TURNING TOOL 阻尼减振车刀

## 阻尼减振车刀刀头

Cartridge for Damping Turning Tool Holder

### 负型 95° 正镗

Negative Type 95° Boring

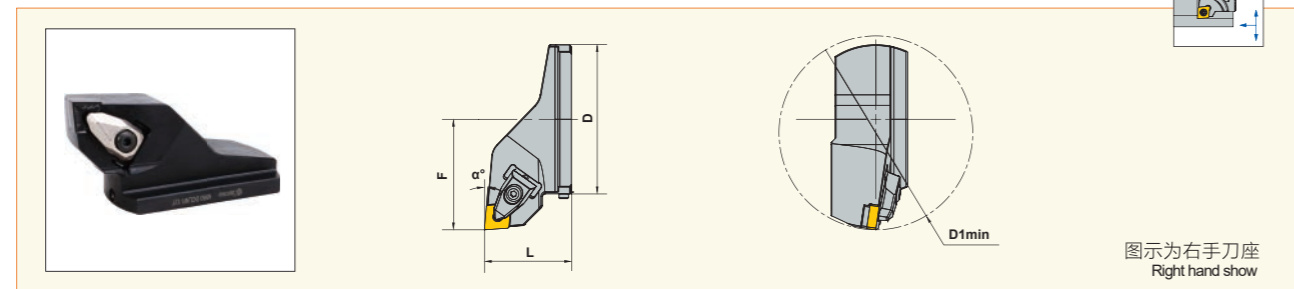

规格型号 Designation	D	D1 min	F	L	α°	Kg	适配刀片 Insert	在庫 Stock
SVH80 DCLNR-12T	80	100	57	45	5°	0.49	CN.. 1204..	○
SVH80 DCLNL-12T	80	100	57	45	5°	0.49	CN.. 1204..	○

- 刀片请根据不同材料单独订购。
- 订货示例：1 件 SVH80 DCLNR-12T。
- The insert should be ordered separately.
- Ordering sample: 1 PC SVH80 DCLNR-12T.

## 备件

Spare Parts



规格型号 Designation	压板 Clamping pad	压板弹簧 Spring for clamping pad	压板螺钉 Screw for clamping pad	刀垫 Shim	压板扳手 Allen key for clamping pad	刀垫锁紧螺钉 Clamping screw for shim	刀垫锁紧扳手 Allen key for shim
SVH80 ..-12T	PB10 DCN12	YH 8x0.6x13	SR59 M5x20	ST01 CN12x3.2	KEY01 M3	SR20 M5x10	KEY03 T20

● 标准库存  
Item in stock

● 半标准库存 (订货时, 请确认交货期)  
Item of short delivery time  
(please confirm delivery time when ordering it)

○ 无库存 (订货时, 请确认交货期)  
Order on demand  
(please confirm delivery time when ordering it)

# DAMPING TURNING TOOL 阻尼减振车刀

## 阻尼减振车刀刀头

Cartridge for Damping Turning Tool Holder

### 负型 93° 正镗及仿形车

Negative Type 93° Boring and Profile-turning

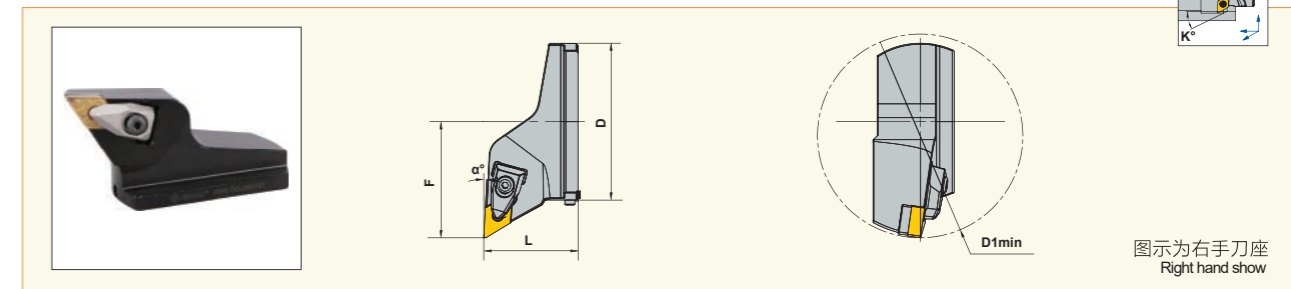

规格型号 Designation	D	D1 min	F	L	α°	K°	Kg	适配刀片 Insert	在庫 Stock
SVH80 DDUNL-15T	80	100	57	46	3°	27°	0.5	DN.. 1506..	○
SVH80 DDUNR-15T	80	100	57	46	3°	27°	0.5	DN.. 1506..	○

- 刀片请根据不同材料单独订购。
- 订货示例：1 件 SVH80 DDUNL-15T。
- The insert should be ordered separately.
- Ordering sample: 1 PC SVH80 DDUNL-15T.

## 备件

Spare Parts



规格型号 Designation	压板 Clamping pad	压板弹簧 Spring for clamping pad	压板螺钉 Screw for clamping pad	刀垫 Shim	压板扳手 Allen key for clamping pad	刀垫锁紧螺钉 Clamping screw for shim	刀垫锁紧扳手 Allen key for shim
SVH80 ...15T	PB10 DCN12	YH 8x0.6x13	SR59 M5x20	ST01 DN15x4.76	KEY01 M3	SR20 M4x11.5	KEY03 T15

● 标准库存  
Item in stock

● 半标准库存 (订货时, 请确认交货期)  
Item of short delivery time  
(please confirm delivery time when ordering it)

○ 无库存 (订货时, 请确认交货期)  
Order on demand  
(please confirm delivery time when ordering it)

# DAMPING TURNING TOOL 阻尼减振车刀

## 阻尼减振车刀刀头

Cartridge for Damping Turning Tool Holder

### 负型 93° 反镗及仿形车

Negative Type 93° Back Boring and Profile-turning

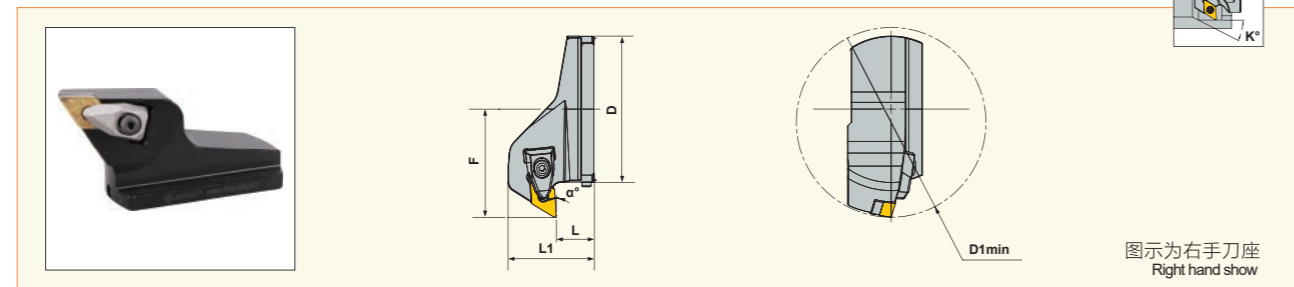

规格型号 Designation	D	D1 min	F	L	L1	α°	K°	Kg	适配刀片 Insert	在庫 Stock
SVH80 DDZNR-15T	80	100	57	20	45	3°	27°	0.55	DN.. 1506..	○
SVH80 DDZNL-15T	80	100	57	20	45	3°	27°	0.55	DN.. 1506..	○

- 刀片请根据不同材料单独订购。
- 订货示例：1 件 SVH80 DDZNR-15T。
- The insert should be ordered separately.
- Ordering sample: 1 PC SVH80 DDZNR-15T.

## 备件

Spare Parts

规格型号 Designation	压板 Clamping pad	压板弹簧 Spring for clamping pad	压板螺钉 Screw for clamping pad	刀垫 Shim	压板扳手 Allen key for clamping pad	刀垫锁紧螺钉 Clamping screw for shim	刀垫锁紧扳手 Allen key for shim
SVH80 ...15T	PB10 DCN12	YH 8x0.6x13	SR59 M5x20	ST01 DN15x4.76	KEY01 M3	SR20 M4x11.5	KEY03 T15

● 标准库存  
Item in stock

◐ 半标准库存 (订货时, 请确认交货期)  
Item of short delivery time  
(please confirm delivery time when ordering it)

○ 无库存 (订货时, 请确认交货期)  
Order on demand  
(please confirm delivery time when ordering it)

# DAMPING TURNING TOOL 阻尼减振车刀

## 阻尼减振车刀刀头

Cartridge for Damping Turning Tool Holder

### 负型 62.5° 仿形车

Negative Type 62.5° Boring and Profile-turning

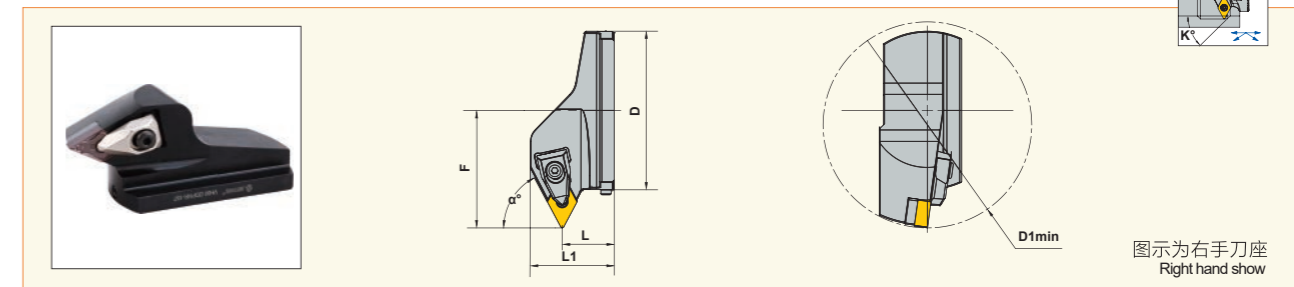

规格型号 Designation	D	D1 min	F	L	L1	α°	K°	Kg	适配刀片 Insert	在庫 Stock
SVH80 DDPNR-15T	80	100	57	25	40.3	62.5°	60°	0.49	DN.. 1506..	○
SVH80 DDPNL-15T	80	100	57	25	40.3	62.5°	60°	0.49	DN.. 1506..	○

- 刀片请根据不同材料单独订购。
- 订货示例：1 件 SVH80 DDPNR-15T。
- The insert should be ordered separately.
- Ordering sample: 1 PC SVH80 DDPNR-15T.

## 备件

Spare Parts

规格型号 Designation	压板 Clamping pad	压板弹簧 Spring for clamping pad	压板螺钉 Screw for clamping pad	刀垫 Shim	压板扳手 Allen key for clamping pad	刀垫锁紧螺钉 Clamping screw for shim	刀垫锁紧扳手 Allen key for shim
SVH80 ...15T	PB10 DCN12	YH 8x0.6x13	SR59 M5x20	ST01 DN15x4.76	KEY01 M3	SR20 M4x11.5	KEY03 T15

● 标准库存  
Item in stock

◐ 半标准库存 (订货时, 请确认交货期)  
Item of short delivery time  
(please confirm delivery time when ordering it)

○ 无库存 (订货时, 请确认交货期)  
Order on demand  
(please confirm delivery time when ordering it)

# DAMPING TURNING TOOL 阻尼减振车刀

## 阻尼减振车刀刀头

Cartridge for Damping Turning Tool Holder

### 负型 93° 反镗及仿形车

Negative Type 93° Boring and Profile-turning

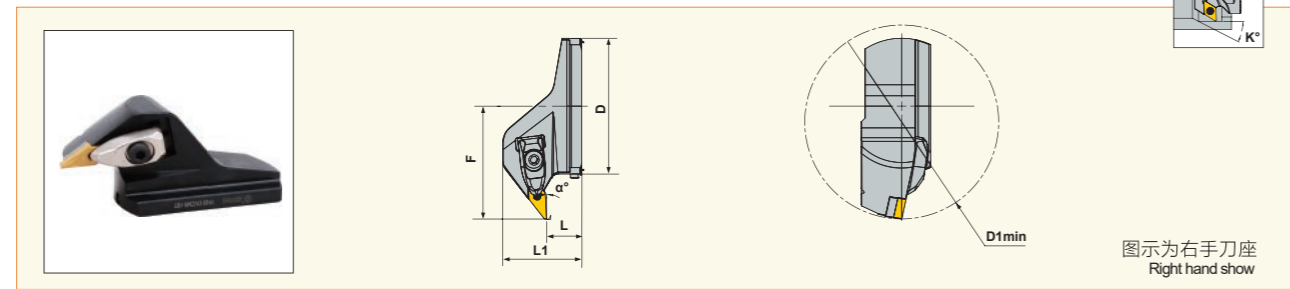

规格型号 Designation	D	D1 min	F	L	L1	$\alpha^\circ$	$K^\circ$	Kg	适配刀片 Insert	在庫 Stock
SVH80 DVZNR-16T	80	110	64	20	45	3°	30°	0.49	VN.. 1604..	○
SVH80 DVZNL-16T	80	110	64	20	45	3°	30°	0.49	VN.. 1604..	○

- 刀片请根据不同材料单独订购。
- 订货示例：1 件 SVH80 DVZNR-16T。
- The insert should be ordered separately.
- Ordering sample: 1 PC SVH80 DVZNR-16T.

## 备件

Spare Parts

规格型号 Designation	压板 Clamping pad	压板弹簧 Spring for clamping pad	压板螺钉 Screw for clamping pad	刀垫 Shim	压板扳手 Allen key for clamping pad	刀垫锁紧螺钉 Clamping screw for shim	刀垫锁紧扳手 Allen key for shim
SVH80 ...-16T	PB10 DVN16	YH 9x0.8x14	SR59 M6x26.5	ST01 VN16x3.2	KEY01 M4	SR20 M3.5x8.5	KEY03 T10

- 标准库存  
Item in stock
- ◐ 半标准库存 (订货时, 请确认交货期)  
Item of short delivery time  
(please confirm delivery time when ordering it)
- 无库存 (订货时, 请确认交货期)  
Order on demand  
(please confirm delivery time when ordering it)

# DAMPING TURNING TOOL 阻尼减振车刀

## 阻尼减振车刀刀头

Cartridge for Damping Turning Tool Holder

### 正型 93° 正镗及仿形车

Positive Type 93° Boring and Profile-turning

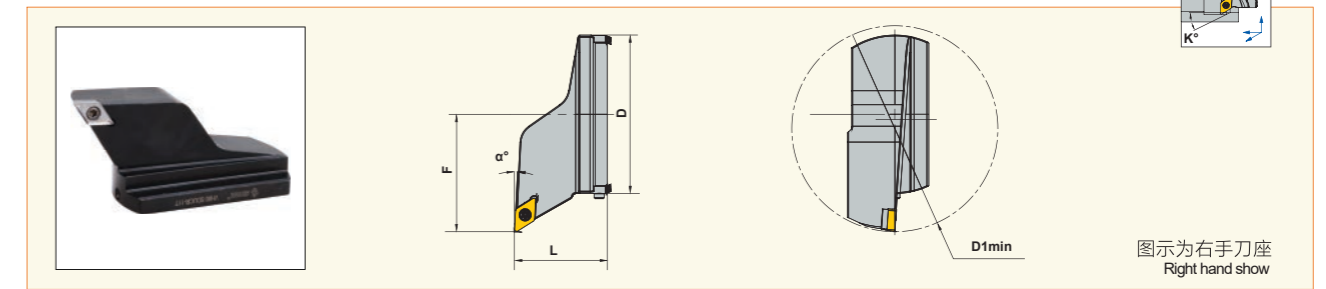

规格型号 Designation	D	D1 min	F	L	$\alpha^\circ$	$K^\circ$	Kg	适配刀片 Insert	在庫 Stock
SVH80 SDUCR-11T	80	100	57	45	3°	27°	0.5	DC.. 11T3..	●
SVH80 SDUCL-11T	80	100	57	45	3°	27°	0.5	DC.. 11T3..	●

- 刀片请根据不同材料单独订购。
- 订货示例：1 件 SVH80 SDUCR-11T。
- The insert should be ordered separately.
- Ordering sample: 1 PC SVH80 SDUCR-11T.

## 备件

Spare Parts

规格型号 Designation	刀片锁紧螺钉 Clamping screw for insert	锁紧扳手 Allen key for clamping	刀垫 Shim	刀垫螺套 Sleeve for shim	刀垫扳手 Allen key for shim
SVH80 ...-11T	SR21 M4x11	KEY03 T15	ST01 DC11x2.82	SRT M6-M4x6.9	KEY01 M4

- 标准库存  
Item in stock
- ◐ 半标准库存 (订货时, 请确认交货期)  
Item of short delivery time  
(please confirm delivery time when ordering it)
- 无库存 (订货时, 请确认交货期)  
Order on demand  
(please confirm delivery time when ordering it)

# DAMPING TURNING TOOL 阻尼减振车刀

## 阻尼减振车刀刀头

Cartridge for Damping Turning Tool Holder

### 正型 95° 正镗及仿形车

Positive Type 95° Boring and Profile-turning

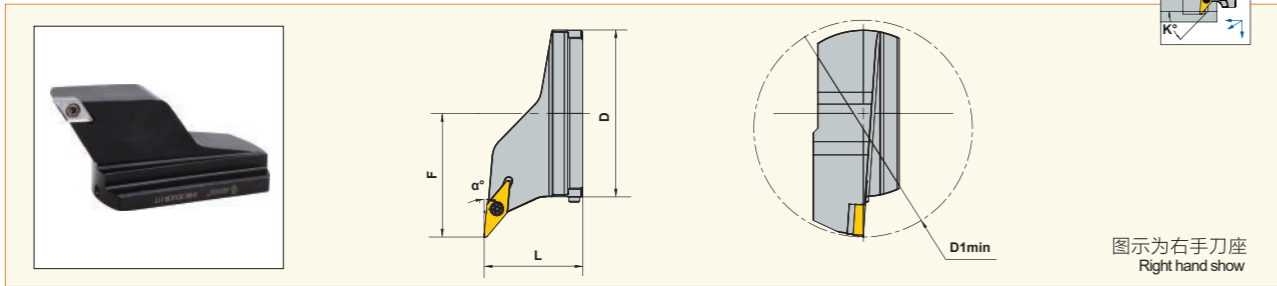
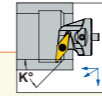

图示为右手刀座  
Right hand show

规格型号 Designation	D	D1 min	F	L	α°	K°	Kg	适配刀片 Insert	在庫 Stock
SVH80 SVLCL-16T	80	100	57	45	5°	45°	0.44	VC.. 1604..	●
SVH80 SVLCL-16T	80	100	57	45	5°	45°	0.44	VC.. 1604..	●

- 刀片请根据不同材料单独订购,
- 订货示例: 1 件 SVH80 SVLCL-16T.
- The insert should be ordered separately.
- Ordering sample: 1 PC SVH80 SVLCL-16T.

## 备件

Spare Parts



规格型号 Designation	刀片锁紧螺钉 Clamping screw for insert	锁紧扳手 Allen key for clamping	刀垫 Shim	刀垫螺套 Sleeve for shim	刀垫扳手 Allen key for shim
SVH80 ..-16T	SR21 M4x11	KEY03 T15	ST01 VC16x2.82	SRT M6-M4x6.9	KEY01 M4

● 标准库存  
Item in stock

● 半标准库存 (订货时, 请确认交货期)  
Item of short delivery time  
(please confirm delivery time when ordering it)

○ 无库存 (订货时, 请确认交货期)  
Order on demand  
(please confirm delivery time when ordering it)

# DAMPING TURNING TOOL 阻尼减振车刀

## 阻尼减振车刀刀头

Cartridge for Damping Turning Tool Holder

### 槽刀头

Grooving Head

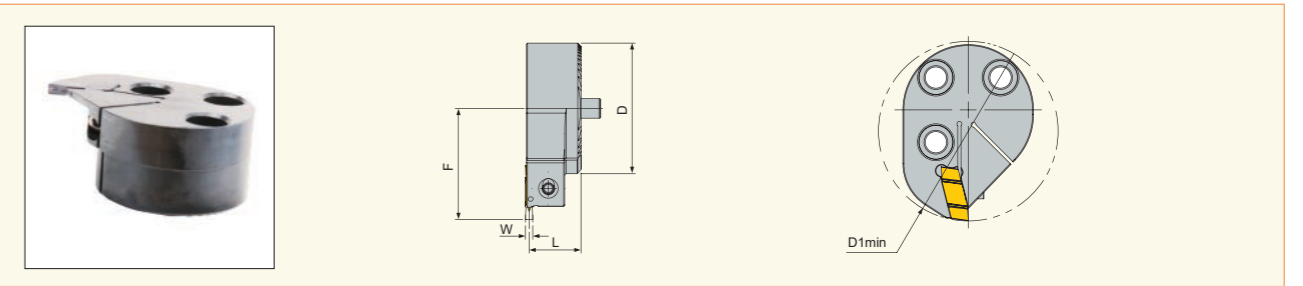

规格型号 Designation	D1 min	W	D	F	L	适配刀片 Insert	在庫 Stock
SVT25 GIR/L-2	31.00	2	25.00	17.50	14.00	HG2002...	●
SVT25 GIR/L-3	31.00	3	25.00	17.50	14.00	HG3003...	●
SVT32 GIR/L-2	37.00	2	32.00	20.00	18.00	HG2002...	●
SVT32 GIR/L-3	37.00	3	32.00	20.00	18.00	HG3003...	●
SVT40 GIR/L-2	45.00	2	40.00	24.00	18.00	HG2002...	●
SVT40 GIR/L-3	46.00	3	40.00	25.00	18.00	HG3003...	●
SVT40 GIR/L-4	49.00	4	40.00	28.00	18.00	HG4004...	●

- 刀片咨询销售工程师.
- Inserts information please contact with sales manager.

## 备件

Spare Parts



规格型号 Designation	刀片锁紧螺钉 Clamping screw for insert	锁紧扳手 Allen key for clamping	定位销 Locating pin
SVT25 GIR/L-2	SR55 M4x12	KEY01 M3	FT39 D6-5x9
SVT25 GIR/L-3	SR55 M4x12	KEY01 M3	FT39 D6-5x9
SVT32 GIR/L-2	SR55 M4x12	KEY01 M3	FT39 D6-5x11
SVT32 GIR/L-3	SR55 M4x12	KEY01 M3	FT39 D6-5x11
SVT40 GIR/L-2	SR55 M4x12	KEY01 M3	FT39 D6-5x11
SVT40 GIR/L-3	SR55 M4x12	KEY01 M3	FT39 D6-5x11
SVT40 GIR/L-4	SR55 M4x12	KEY01 M3	FT39 D6-5x11

● 标准库存  
Item in stock

● 半标准库存 (订货时, 请确认交货期)  
Item of short delivery time  
(please confirm delivery time when ordering it)

○ 无库存 (订货时, 请确认交货期)  
Order on demand  
(please confirm delivery time when ordering it)

# DAMPING TURNING TOOL 阻尼减振车刀

## 阻尼减振车刀刀头

Cartridge for Damping Turning Tool Holder

## 螺纹刀头

Threading Tool Cartridge

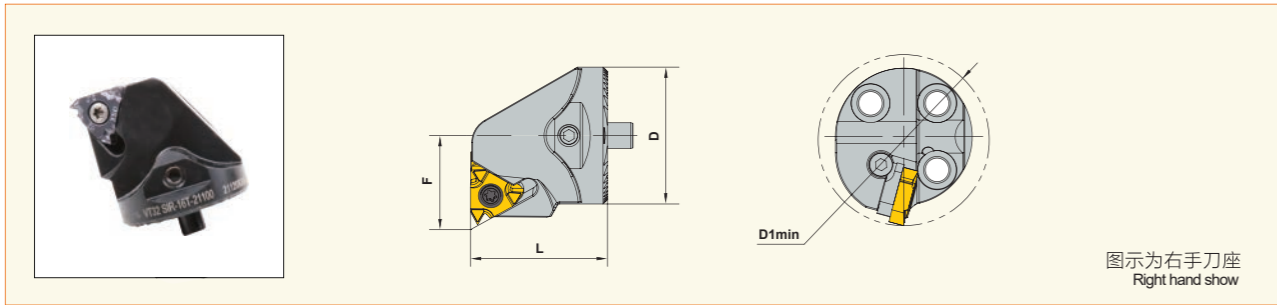

规格型号 Designation	D	D1 min	F	L	Kg	适配刀片 Insert	在庫 Stock
SVT20 SIR/L-16	20	25	14	25	0.04	16IR/L	●
SVT25 SIR/L-16T	25	32	17	25	0.05	16IR/L	●
SVT32 SIR/L-16T	32	40	22	32	0.11	16IR/L	●
SVT32 SIR/L-22T	32	40	22	32	0.11	22IR/L	●
SVT40 SIR/L-16T	40	50	27	32	0.17	16IR/L	●
SVT40 SIR/L-22T	40	50	27	32	0.17	22IR/L	●

- 刀片请根据不同材料单独订购。
- 订货示例: 1 件 SVT20 SIR/L-16。
- The insert should be ordered separately.
- Ordering sample: 1 PC SVT20 SIR/L-16.

## 备件

Spare Parts



规格型号 Designation	刀片锁紧螺钉 Clamping screw for insert	锁紧扳手 Allen key for clamping	刀垫 Shim	刀垫螺定 Sleeve for shim	定位销 Locating pin
SVT20 SIR/L-16	SR20 M3.5x11.5	KEY02 T10	-	-	FT39 D6-5x8
SVT25 SIR/L-16T	SR20 M3.5x11.5	KEY02 T10	AI16	SR55 M3x6	FT39 D6-5x9
SVT32 SIR/L-16T	SR20 M3.5x11.5	KEY02 T10	AI16	SR55 M3x6	FT39 D6-5x11
SVT32 SIR/L-22T	SR20 M4x15	KEY02 T15	AI22	SR55 M3x6	FT39 D6-5x11
SVT40 SIR/L-16T	SR20 M3.5x11.5	KEY02 T10	AI16	SR55 M3x6	FT39 D6-5x11
SVT40 SIR/L-22T	SR20 M4x15	KEY02 T15	AI22	SR55 M3x6	FT39 D6-5x11

● 标准库存  
Item in stock

● 半标准库存 (订货时, 请确认交货期)  
Item of short delivery time  
(please confirm delivery time when ordering it)

○ 无库存 (订货时, 请确认交货期)  
Order on demand  
(please confirm delivery time when ordering it)

# DAMPING TURNING TOOL 阻尼减振车刀

## 中心校准块

Centre Calibration Block

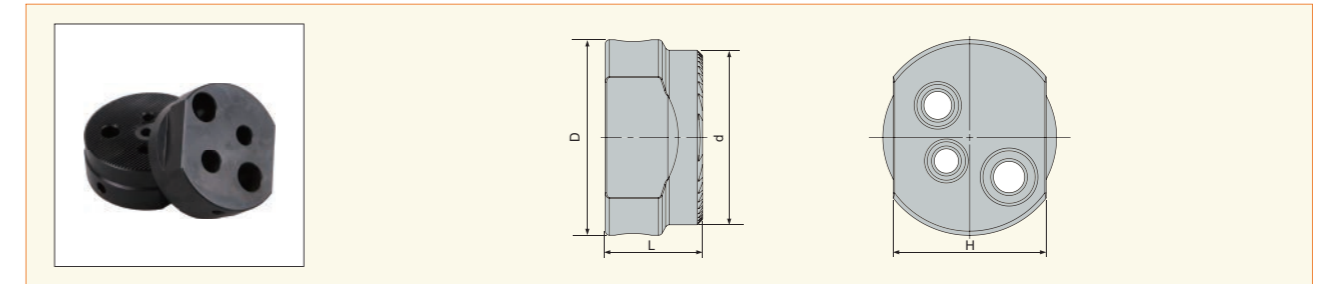

规格型号 Designation	D	d	H	L	适用刀杆 Boring bar	Kg	在庫 Stock
SVTXZ 16-25	28	25	22	14	VT16/VT20/VT25	0.05	●
SVTXZ 32-60	62	60	52	25	VT32/VT40/VT50/VT60	0.45	●

- 订货示例: 1 件 SVTXZ 16-25
- Ordering sample: 1 PC SVTXZ 16-25

## 快换刀座

Quick-Change Cartridge

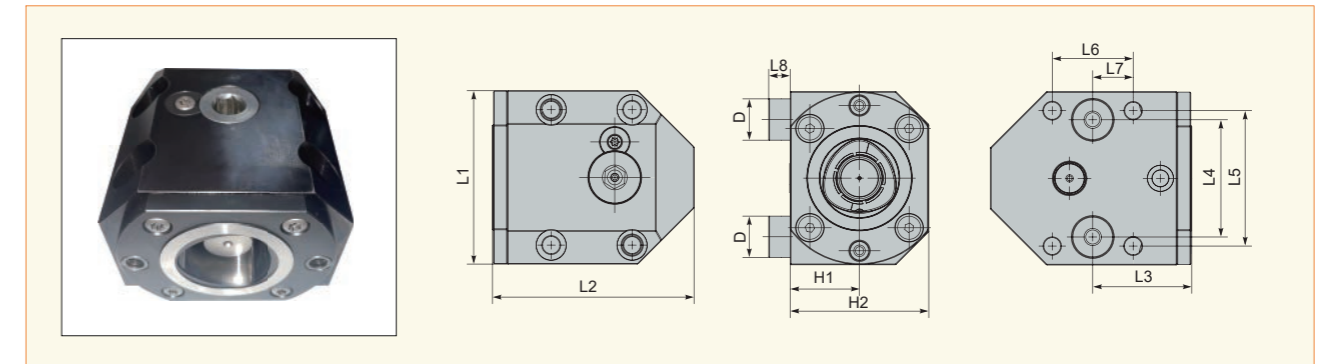

规格型号 Designation	接口尺寸 Size of Connection	H1	H2	L1	L2	L3	Kg	在庫 Stock
MGA S42xD25-60-LC6.R	C6	42	84	105	122	60	5.85	○

规格型号 Designation	安装尺寸 Assembly Size						压紧螺钉 Clamping screw
	D(h7)	L4	L5	L6	L7	L8	
MGA S42xD25-60-C6.R	25	71	82	49	24.5	20	M10

- 标准库存
- 半标准库存 (订货时, 请确认交货期)
- 无库存 (订货时, 请确认交货期)

● 标准库存  
Item in stock

● 半标准库存 (订货时, 请确认交货期)  
Item of short delivery time  
(please confirm delivery time when ordering it)

○ 无库存 (订货时, 请确认交货期)  
Order on demand  
(please confirm delivery time when ordering it)

# DAMPING TURNING TOOL 阻尼减振车刀

## 车床用变径套

Reduction Sleeve for Turning Lathe

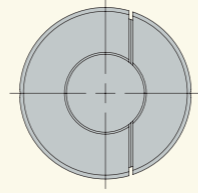
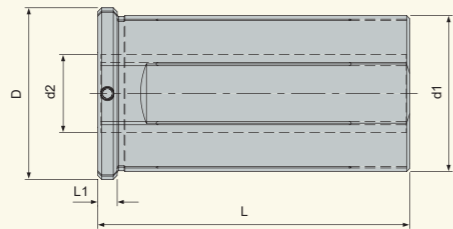

规格型号 Designation	D	d1	d2	L	L1	在庫 Stock
RS SD32-16x65	36	32	16	65	5	●
RS SD32-20x65	36	32	20	65	5	●
RS SD32-20x85	38	32	20	85	5	●
RS SD40-16x75	44	40	16	75	5	●
RS SD40-20x75	44	40	20	75	5	●
RS SD40-25x75	44	40	25	75	5	●
RS SD40-20x105	46	40	20	105	5	●
RS SD40-25x105	46	40	25	105	5	●
RS SD40-32x128	50	40	32	128	5	●
RS SD50-20x125	56	50	20	125	5	●
RS SD50-25x125	56	50	25	125	5	●
RS SD50-32x128	60	50	32	128	5	●
RS SD50-40x160	60	50	40	160	5	●
RS SD60-32x128	70	60	32	128	5	●
RS SD60-40x160	70	60	40	160	5	●
RS SD60-50x200	70	60	50	200	5	●

- 订货示例: 1 件 RS D32-16x65
- Ordering sample: 1 PC RS D32-16x65

# DAMPING TURNING TOOL 阻尼减振车刀

## 车刀转接头

Adapter for Head

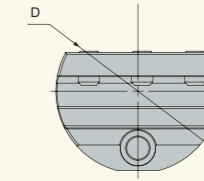
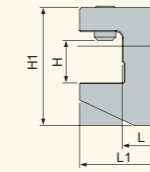

规格型号 Designation	D	H	H1	L	L1	Kg	在庫 Stock
SVH80 2020R.40	80	20	55	20	40	0.73	●

- 订货示例: 1 件 SVH80 2020R.40
- Ordering sample: 1 PC SVH80 2020R.40

## 备件

Spare Parts



规格型号 Designation	锁紧螺钉 Clamping screw	锁紧扳手 Allen key for clamping
SVH80 2020R.40	SR54 M10x16	KEY01 M5

## 刀杆转接头

Adapter for Tool Holder

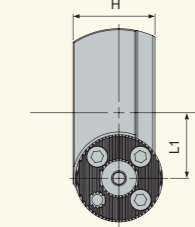
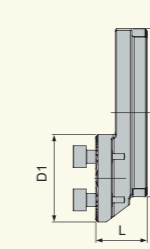

规格型号 Designation	D	D1	H	L	L1	Kg	在庫 Stock
RE SVH80-VT40R/L	80	40	37	23	30	0.33	●

- 订货示例: 1 件 RE SVH80-VT40R
- Ordering sample: 1 PC RE SVH80-VT40R

## 备件

Spare Parts



规格型号 Designation	锁紧螺钉 Clamping screw	调节螺钉 Adjusting screw	锁紧扳手 Allen key for clamping	调节扳手 Allen key for adjusting screw
RE SVH80-VT40R/L	SR50 M5x25	SR55 M6x12	KEY01 M5	KEY01 M2.5

- 标准库存  
Item in stock
- 半标准库存 (订货时, 请确认交货期)  
Item of short delivery time  
(please confirm delivery time when ordering it)
- 无库存 (订货时, 请确认交货期)  
Order on demand  
(please confirm delivery time when ordering it)

- 标准库存  
Item in stock
- 半标准库存 (订货时, 请确认交货期)  
Item of short delivery time  
(please confirm delivery time when ordering it)
- 无库存 (订货时, 请确认交货期)  
Order on demand  
(please confirm delivery time when ordering it)

# DAMPING TURNING TOOL 阻尼减振车刀

## 阻尼减振车刀使用说明

User Guide for Damping Turning Tool

### 减振刀具安装及调整

Assembly and Adjusting

#### 1. 准备

安装配合部位必须擦拭干净，如：减振刀杆及刀头 V 型定位槽、减振刀杆柄部外圆及安装座内孔，见下图 A、B 两处示意位置。

#### Assembly and Adjusting

Preparation

Wipe clean the positions which need to be assembled, like V geometric slot on the cartridge and shank, the end of the shank which will be connected with adaptor, and internal hole on the clamping holder. See A and B position on the following visual.

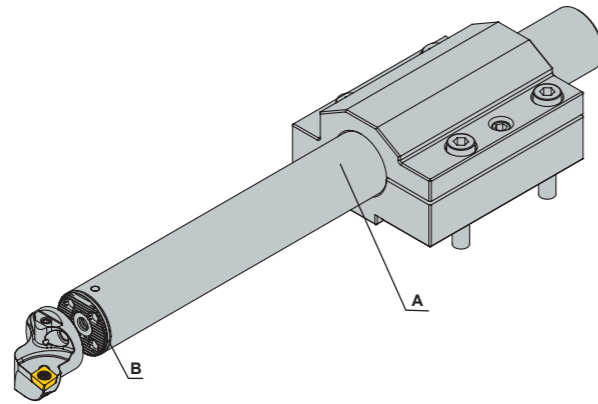

#### 2. 刀杆的安装

安装夹持长度不少于刀杆径的 4 倍，使用开口夹套等抱紧装夹方式，禁止使用螺钉直压等锁紧方式，长时间使用必须使用内冷却，如下图所示。

Assembly for the Shank

The clamping length should not be less than 4 L/D ratio. Suggest using the clamping cover with opening method and other holding clamping methods. Do not use screw clamping method. Use inner cooling please when working a long time.

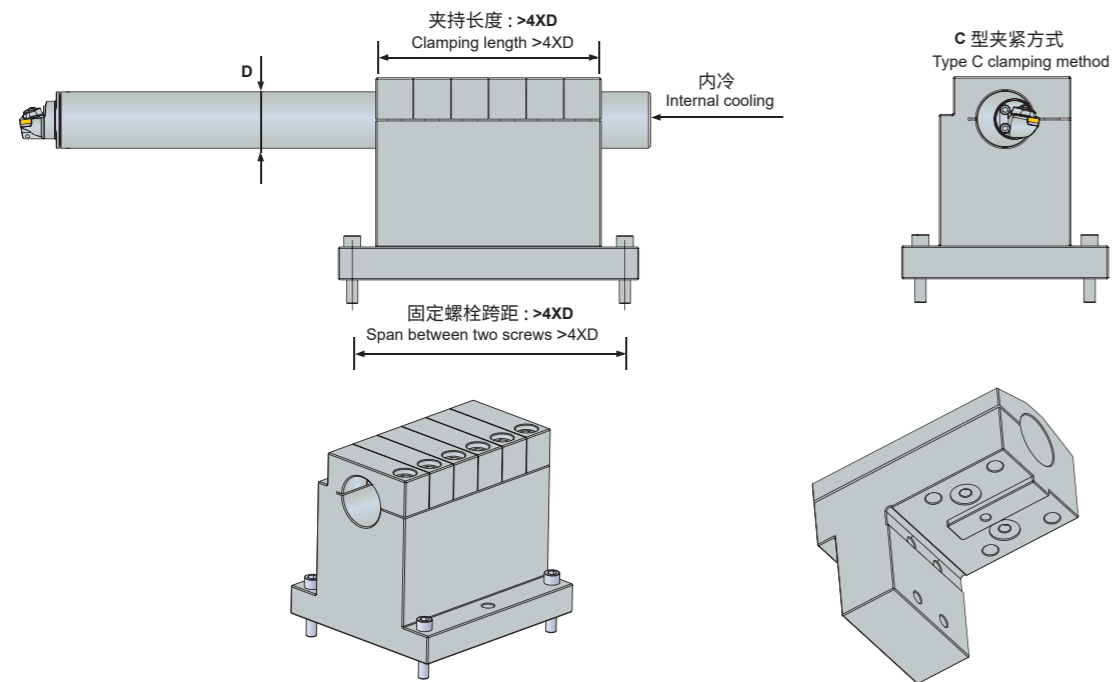

# DAMPING TURNING TOOL 阻尼减振车刀

## 阻尼减振车刀使用说明

User Guide for Damping Turning Tool

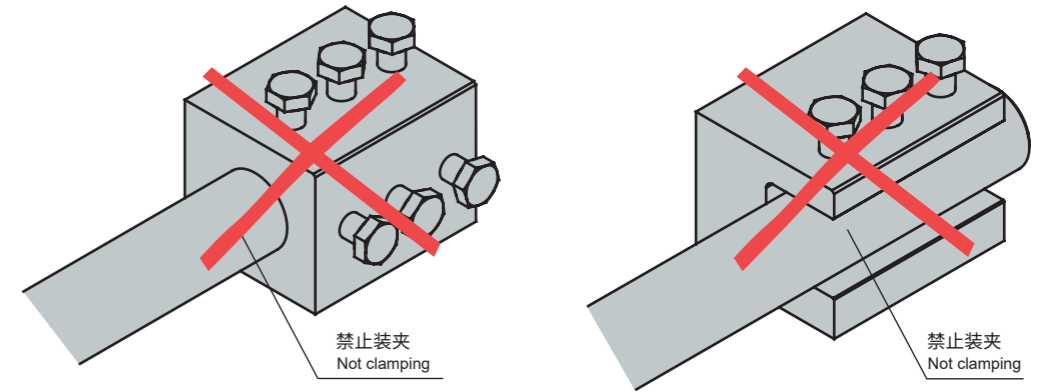

#### 3. 中心高调整

首次安装刀杆需要使用专用中心高校准工具，安装于车刀杆齿形槽接口处，锁紧，沿机床 X 轴方向校准基准平面 0.01 以内，锁紧刀杆后拆掉校准工具。

Adjust the Height of Centre

Exclusive calibration tool for the height of centre should be used when assembling the shank at the first time. Assemble the shank into the V geometric slot firstly, then calibrate it within 0.01 tolerance on the X-axis direction.

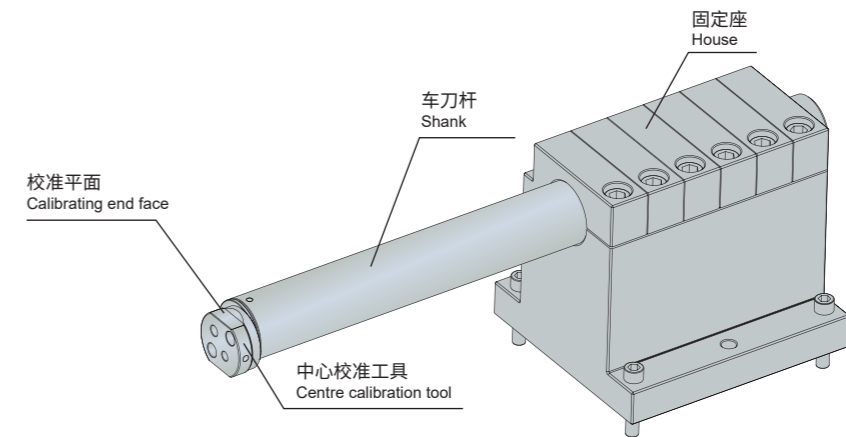

#### 4. 安装正确的车刀头

Assemble the right cartridge, see below figure

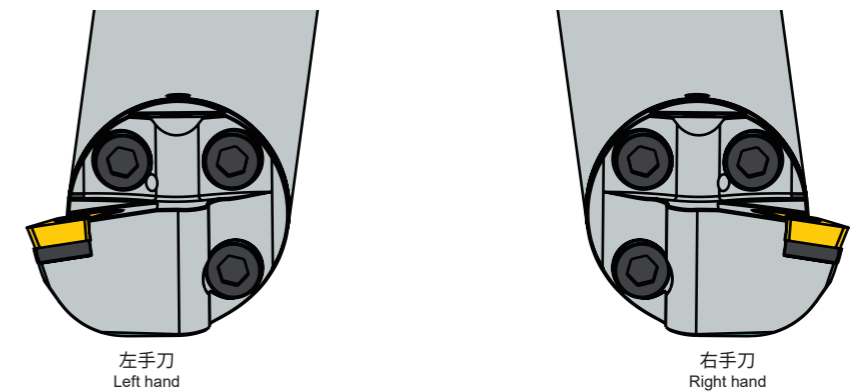

# DAMPING TURNING TOOL 阻尼减振车刀

## 阻尼减振车刀使用说明

User Guide for Damping Turning Tool

### 减振刀杆的长度调整

1. 推荐最小夹持长度 4xD
2. 镗杆可改制，切断后的长度如下表

#### Adjusting the Length of the Shank

1. Suggested min. clamping length is 4xD
2. The boring bar can be cut off, the final length please see below figure: clamping holder. See A and B position on the following visual.

产品类别 Type	切断后的最小长度 (L) Min. length after cutting off	
	4-7xD(mm)	7-10xD(mm)
D(mm)		
16	100	-
20	125	-
25	155	255
32	190	320
40	240	410
50	305	520
60	380	630
80	630	630
100	770	770

3. 后缀为 VE 系列的车刀杆禁止切断调整长度，如：SVT16 C16-204VE，如下图所示：

3. Please do not cut off the adjusting length if the shank designation ends in VE. Example: SVT16 C16-204VE, see below figure:

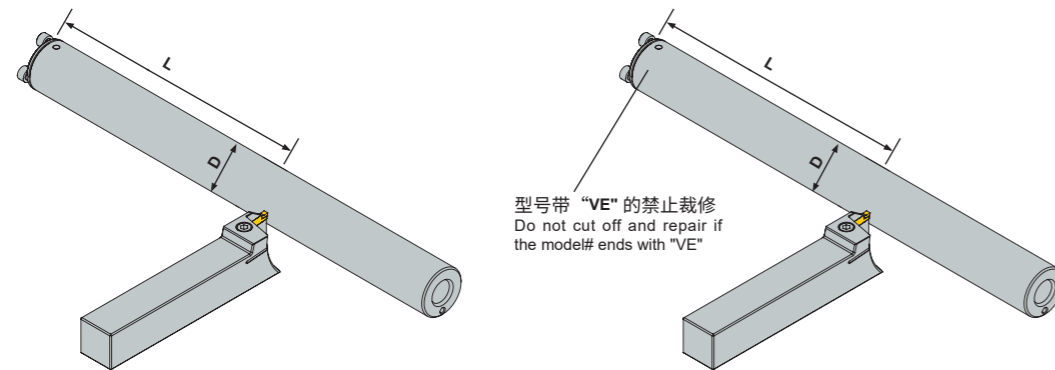

# DAMPING TURNING TOOL 阻尼减振车刀

## 阻尼减振车刀使用说明

User Guide for Damping Turning Tool

### 减振车刀使用环境要求

Environment for Damping Turning Tool

刀杆型号 Designation	悬伸长度 / 直径 Overhang length/ Diameter	内冷压力 MAX (Bar) MAX: Internal cooling pressure	使用温度 MAX(°C) Operating temperature
SVT16 C16-156V	7	30	100
SVT16 C16-204VE	10	30	100
SVT20 C20-200V	7	30	100
SVT20 C20-260VE	10	30	100
SVT25 C25-255V	7	40	100
SVT25 C25-330V	10	40	100
SVT32 C32-320V	7	50	100
SVT32 C32-416V	10	50	100
SVT40 C40-408V	7	70	100
SVT40 C40-528V	10	70	100
SVT50 C50-518V	7	70	100
SVT50 C50-668V	10	70	100
SVT60 C60-628V	7	70	100
SVT60 C60-808V	10	70	100
SVH80 C80-880V	7	70	100
SVH80 C80-1200V	10	70	100