

# WECAN CUTTING TOOLS

2025-2026

WECAN CUTTING TOOLS

# WECAN



<http://www.wecotools.com/>

**ZHUZHOU WECAN CUTTING TOOLS CO., LTD.**

Add: No. 333, South Xinma Road, Tianyuan District,  
Zhuzhou City, Hunan, China.

Tel: +86-731-2883 5599

P.O. Code:412007

Email:support@wecotools.com

**2025-2026**



# WECAN

CUTTING TOOLS

Zhuzhou Wecan Cutting Tools Co., Ltd. was founded in Dec. 2017, with registered capital of 42.45 million US dollars, the member of SHAREATE TOOLS LTD. (stock code: 688257). We are located in Zhuzhou, the capital of cemented carbide in China, covering an area of 20,000 square meters. WeCan owns modern standard workshops with international advanced production and testing equipments.

WeCan is a high-tech enterprise specializing in the research and development, production and sales of carbide CNC indexable inserts, with strong independent research and development and innovation capabilities and great prospects.

WeCan focuses on the R&D and production of CNC inserts matrix material, chip breaker, finishing, surface and coating, focusing on the solution of blade edge integrity, dimensional consistency, performance stability, and is committed to automotive parts, machine tools, molds and other industries to provide high quality products, professional technical solutions and technical service programs.

WeCan is able to customize production for customers. At present, our main products are turning inserts, milling inserts, drilling inserts, grooving inserts and threading inserts. All in order to provide customers with high quality and satisfactory products.

WeCan has always been adhering to customer-centered, customer-oriented requirements, vigorously promoting technological innovation, and gradually building an effective technology development system of "producing this generation of products while developing on the next generation of products", and building up a professional division of labor and multi-disciplinary. Cross-integrated R&D team, we currently own a group of experienced senior and intermediate technical personnel.

In an increasingly competitive market, speed becomes a particularly important competitive advantage. Our corporation invests more than 10% of its sales as research and development expenses every year to quickly launch new products. WeCan is an industry-university-research cooperation unit of Central South University and a new material industry innovation incubation center in Zhuzhou.

WeCan always adhere to the quality policy of "taking market demand as the guide, technological innovation as the core, product quality as the focus, and customer satisfaction as the criterion", and fully implements the ISO9001:2015 quality management system, ISO14001:2015 environmental management system and ISO45001:2018 occupational health and safety management system, closely focus on customer needs, and continuously improve product quality and technical services.

All in order to provide customers with high-quality and satisfactory products. The company adheres to "integrity and innovation, mutual benefit and win-win, and common development". Creating higher value for customers is our constant commitment, WeCan sincerely looks forward to cooperating with you.





High Quality Guarantee

# WECAN

WeCan owns a complete CNC insert production line, including compound preparation, mold making, deep processing, coating, etc., and is committed to the R&D and application solutions of high-performance CNC blades.

Equipped with several world's top precision high-end equipment, OSTERWALDER multi-axis electric press, CNC peripheral grinder, Balzers coating furnace, WeCan adopts automatic numerical control equipments for raw material preparation, pressing, sintering, coating and product inspection. Also WeCan has advanced equipments such as Mikron machining center and Carl Zeiss CMM. At the same time, WeCan applies a variety of international leading coating processes and world-class quality control system to ensure the same quality of each insert, provide customers with high-quality CNC blades and improve the production efficiency of users, and fully meet the market's high requirements for product quality.



# Contents

<b>A</b>	Turning Inserts	A01-A136
<b>B</b>	Milling Inserts	B01-B48
<b>C</b>	Drilling Inserts	C01-C05
<b>D</b>	Technical Information	D01-D15

## Turning Inserts

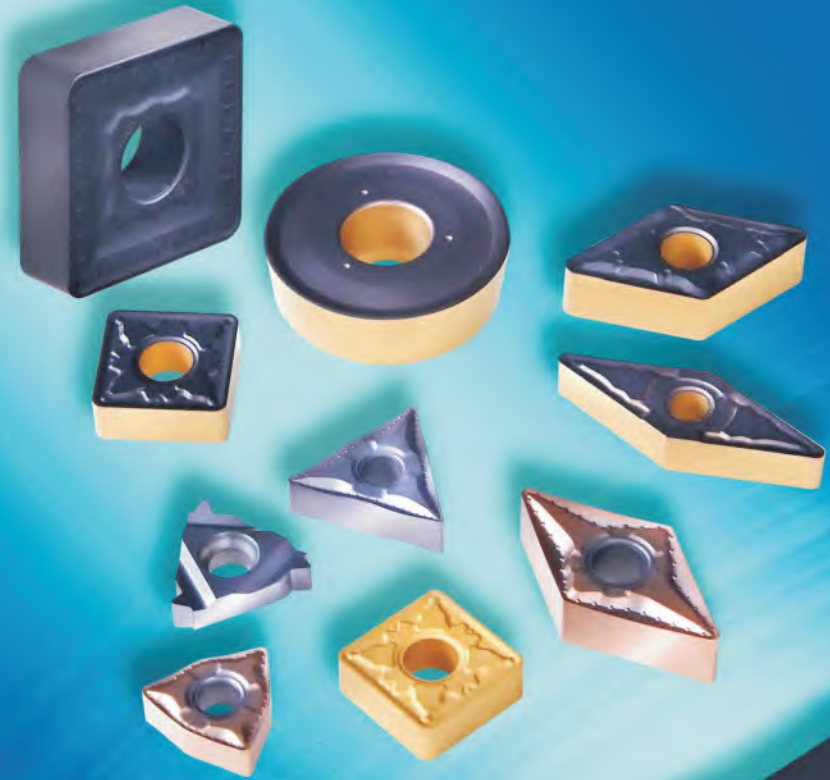

WEGAM



**Speed = Efficiency** **New**

**VR series - Machining of high temperature alloys at line speeds of up to 80m/min**

PVD for Hi-temp Alloy

**VR1X10/1X25/1X31**

**Technical Features**

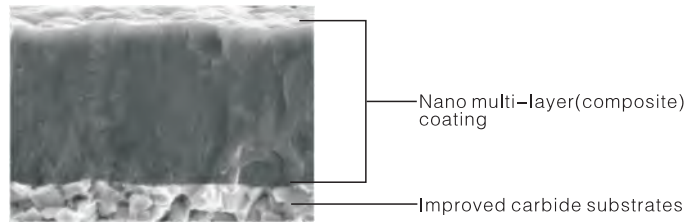

- 1** Improved special matrix for increased hardness and strength at high temperatures
- 2** Nano multi-layer, composite coating technology, precise control of coating composition
- 3** Excellent bonding between coating and substrate and inter-coatings bonding to ensure stable processing
- 4** Special post-treatment process, smooth and dense coating surface, high bonding strength; reduce cutting resistance, improve tool life and workpiece finish

## VR1010

The ultra-fine grain matrix strengthened by the bonding phase has excellent heat resistance and wear resistance. It is suitable for finishing/semi-finishing turning of heat-resistant alloys and hardend materials, and general-purpose milling of hardened materials.

## VR1525

General grade that combines wear resistance and toughness. Excellent heat resistance and oxidation resistance, the first choice for semi-finish machining of high temperature alloys

## VR1031

Excellent tough matrix combined with nano multi-layer coating. Excellent chipping resistance, ideal for rough milling of high temperature alloys



### 1 Cutting Characteristics of Ni-based High Temperature Alloys

- A. High cutting force; high temperature alloys have good plasticity and high strength, and the cutting force required for processing is 2–5 times that of ordinary steel.
- B. High cutting temperature: High temperature alloys have low thermal conductivity, so heat is concentrated and not easily diffused during machining. Fast tool abrasion.
- C. Machining hardening is serious: when cutting, its hardness of the machining surface and the machined surface is 50–100% higher than the substrate
- D. Tool is easy to wear: easy to bond, spread, oxidation and groove wear when cutting
- E. Difficult to break chips: high temperature alloy chips are hard and tough, not easy to break, and difficult to chip discharge

### 2 Features of -DM Chip Breaker for High Temperature Alloy



- Double large rake angle design, sharp cutting edge, low cutting resistance, reduce groove wear effectively
- Special chip breaker and sufficient chip pocket design for effective chip breaking and holding
- Special treatment of the cutting edge, good integrity and high wear resistance
- Good coating adhesion, smooth surface, smooth chip removal, good blade life

### Cutting Range Chart

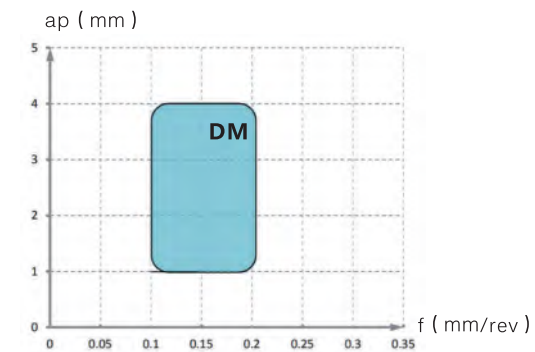

### Case No.1

Workpiece: Aircraft Components  
 Workpiece material: Inconel 718  
 Processing equipment: vertical lathe  
 WeCan insert: CNMG120408-DM VR1510  
 Comparison insert: CNMG120408, a foreign brand  
 Comparison insert: CNMG120408, b foreign brand  
 Processing: Turning  
 Cutting parameters:  $V_c$ : 55m/min  
                                    $f$ : 0.23mm/rev  
                                    $a_p$ : 0.5mm

Conclusion: Our insert takes 26 minutes to process, while the two competitors take 15 minutes to process.

From the perspective of insert wear, WeCan's insert wear is relatively small, and the cost-effectiveness is extremely high.

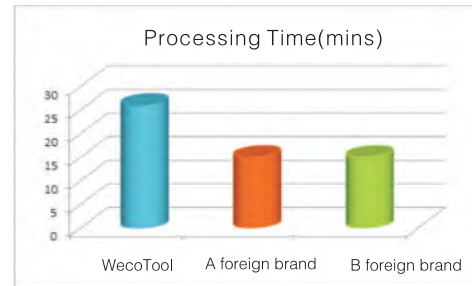

### Case No.2

Workpiece: Aircraft Components  
 Workpiece material: Inconel 718  
 Processing equipment: horizontal lathe  
 WeCan insert: CNMG120408-DM VR1510  
 Comparison insert: CNMG120408, a foreign brand  
 Comparison insert: CNMG120408, b foreign brand  
 Processing: Turning  
 Cutting parameters:  $V_c$ : 55m/min  
                                    $f$ : 0.28mm/rev  
                                    $a_p$ : 3.8mm

Conclusion: Our insert processing takes 8 minutes, while our two competitors process for 4 and 5 minutes respectively. Our insert life is better than our competitors, and the cost-effectiveness is higher.

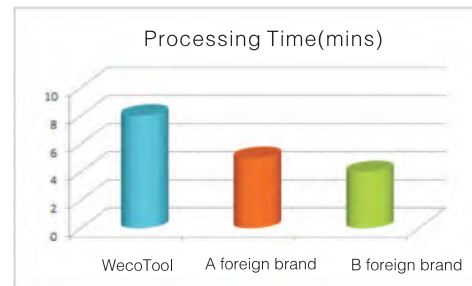

### Case No.3

Workpiece material: cast steel Inconel 718  
 Workpiece: Top Wire  
 Cooling type: Fluid cooling  
 Comparison insert: a foreign brand  
 WeCan Insert: WNMG080408-DM VR1525

Cutting parameters:  $V_c$ : 40m/min,  $a_p$ : 2mm,  $f$ : 0.21mm/rev

Conclusion: Our insert cutting is light and fast, with good chip breaking and low cutting resistance, which is comparable to the lifespan of a foreign brand. However, our insert has a high cost performance ratio.

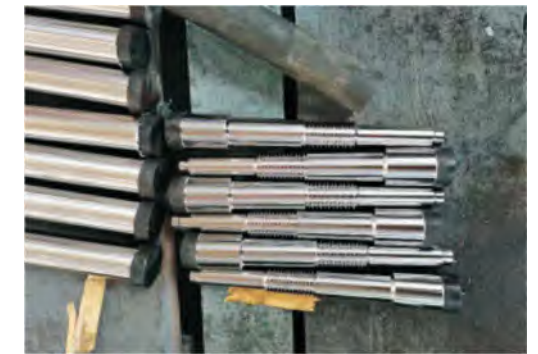
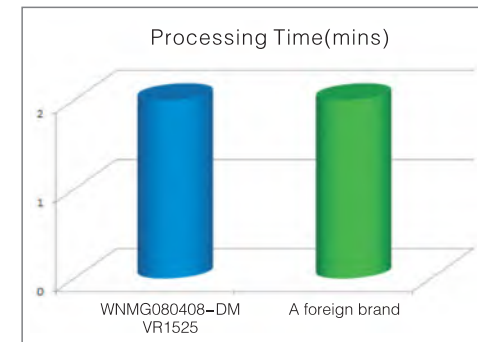

## Heat Resistant Alloys / Titanium Alloys Finishing Series



### VK1605

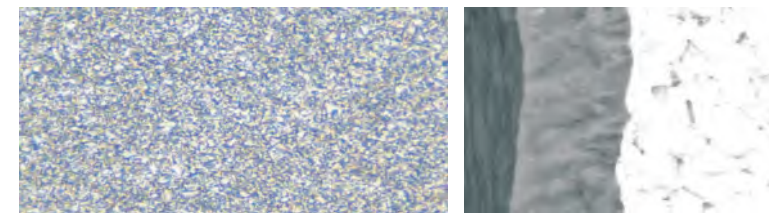

- ★ ISO:S05-S15 H05-H15 N05-N15
- ★ Low cobalt, ultra-fine grain hard alloy matrix, excellent wear resistance and heat resistance;
- ★ Paired with PVD High Power Impulse Magnetron Sputtering (HIPIMS) nano composite coating, the strongest coating adhesion and smooth surface;
  1. High hardness turning grade for small parts;
  2. Suitable for turning of P, M, and S type materials;
  3. Longer processing life and higher surface smoothness.

### Chip Breaker Features of -FL

- Precision grinding of the periphery, with high indexing accuracy.
- The large rake angle design makes a very sharp edge structure.
- The sharp cutting edge design ensures low cutting force and wide edge band further ensuring the sharpness of the cutting edge and ensuring good chip breaking.

Surface polishing treatment and smooth chip discharge lead to excellent surface processing quality.

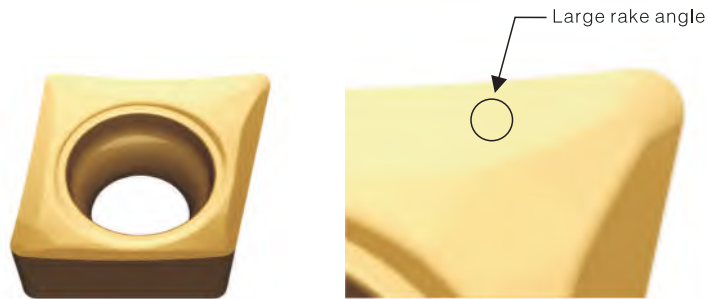

### Case No.1

Workpiece: Aircraft Components  
 Workpiece material: GH4169  
 Processing equipment: horizontal lathe  
 WeCan insert: CCGT09T302-FL VK1605  
 Comparison insert: CCGT09T302 a foreign brand  
 Processing: Turning  
 Cutting parameters: Vc: 40m/min f: 0.15mm/rev ap: 0.1mm  
 Conclusion: Under the same parameter conditions, after processing for 1 hour, the wear of our insert and the safety insert are relatively similar, with a similar lifespan. Our insert has a high cost performance ratio.

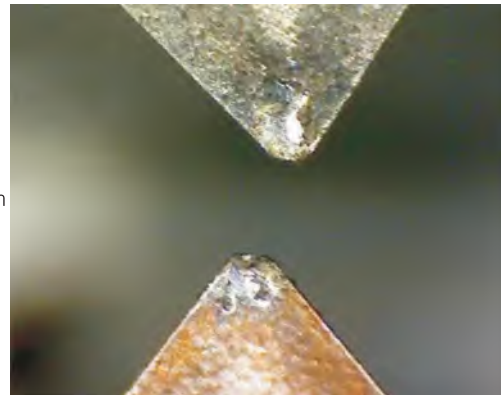

## Processing Sword for Stainless Steel

### 1 Chip Breaker Features of Stainless Steel Finishing -BF

- Double large positive rake angle, fully ensure the sharpness of the edge
- Small protrusions are more conducive to chip breaks
- Large cutting edge inclination can guide the chip flow very well
- Low cutting resistance, high surface finish of machined parts

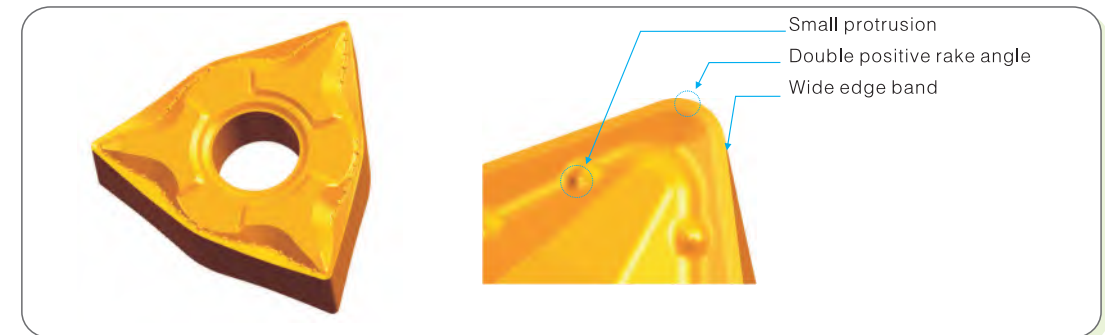

### 2 Chip Breaker Features of Stainless Steel Semi-Finishing -BM

- The combination of variable blade width and variable rake angle takes into account the sharpness and strength of the cutting edge.
- Plum-shaped chip breaker structure, widen the chip breaking range of the insert
- Suitable for semi-finishing of stainless steel.

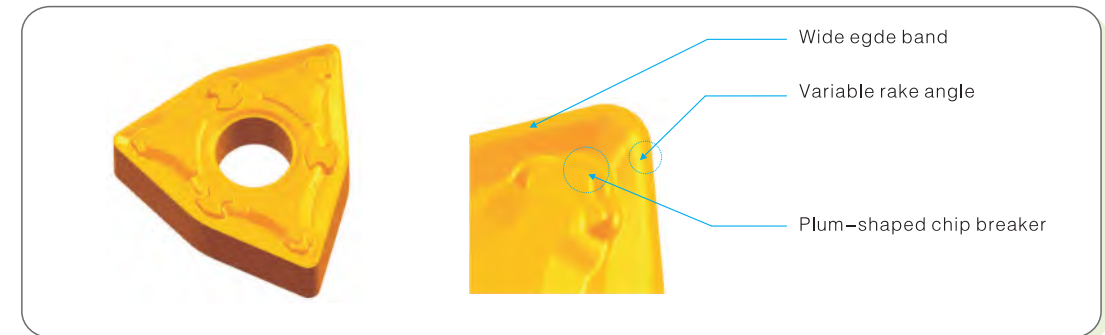

### 3 Chip Breaker Features of Stainless Steel Finishing -BR

- Variable blade width and variable rake angle design, taking into account the sharpness and strength of the blade
- Large chip breaker and chip pocket design provides excellent chip breaking effect.
- Double chip breaker design expands the backbreaking range.
- Suitable for semi-finishing to rough machining of stainless steel

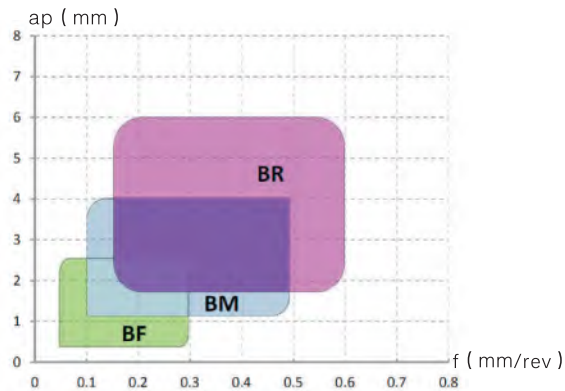
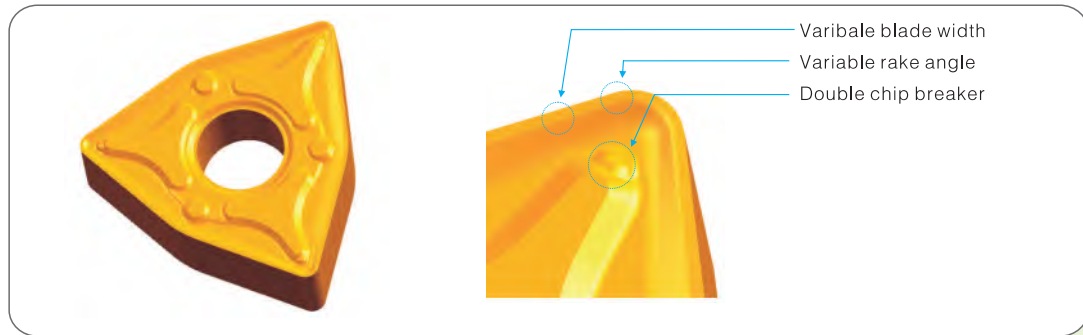

### Case No.1

Workpiece material:stainless steel SUS304  
 Workpiece: Flange  
 Cooling type:Fluid cooling  
 Original blade:A foreign brand  
 WeCan insert:WNMG080408-BR VK1828  
 Cutting parameter:Vc:153m/min, f:0.2mm/rev, ap:1-2mm  
 Conclusion: Used for boring, uneven cutting allowance, our inserts processed 48 pieces, a foreign brand processed 41 pieces, tool life increased by 17%, and has the advantage of cost performance.

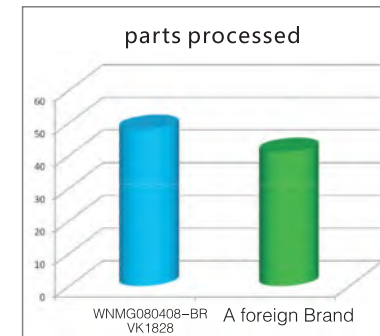

### Case No.2

Workpiece material:stainless steel SUS304  
 Workpiece:Flange  
 Cooling type:Fluid cooling  
 Original blade:A foreign brand  
 WeCan insert:WNMG080408-BR VK1828  
 Cutting parameter:Vc:170m/min, f:0.2mm/rev, ap:1-1.5mm  
 Conclusion: Processing stainless steel flange end face, our inserts processed 69 pieces, a foreign brand processed 56 pieces, tool life increased by 23%, the advantage is obvious and the customer is very satisfied.

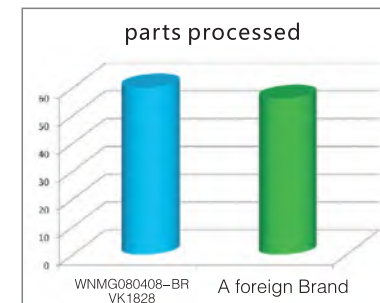

### Case No.3

Workpiece material:stainless steel SUS304  
 Workpiece: Flange  
 Cooling type:Fluid cooling  
 Original blade:A foreign brand  
 WeCan insert:WNMG080408-BM VK1825  
 Cutting parameter:Vc:220m/min f:0.2-0.3mm/rev ap:0.8-1.5mm  
 Conclusion: processing flange outer circle, our inserts processed 16 pieces, a foreign brand processed 14 pieces, tool life increased by 14%, and our inserts processing work piece surface finish better than competitors.

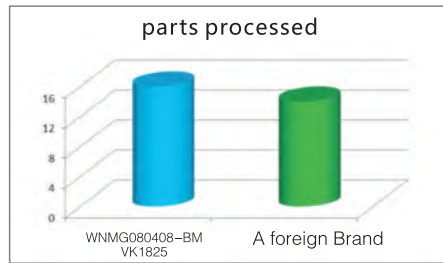

### Case No.4

Workpiece material:stainless steel SUS304  
 Workpiece:pipe joint  
 Cooling type:Fluid cooling  
 Original blade:A foreign brand  
 WeCan insert:TNMG160404-BF VK1828  
 Cutting parameter:Vc:47m/min f:0.1mm/rev ap:1mm  
 Conclusion: Machining the outer circle of pipe joint, our inserts processed 68 pieces, a foreign brand processed 49 pieces, the tool life increased by 39%, the cost performance advantage is obvious.

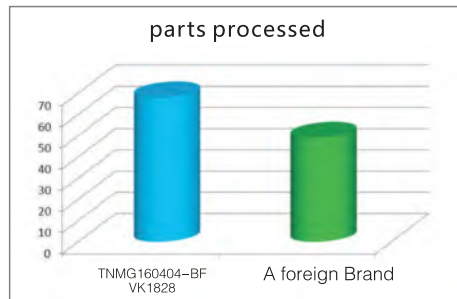

## VK44SERIES

**NEW**

### Upgraded CVD Material for Steel Processing

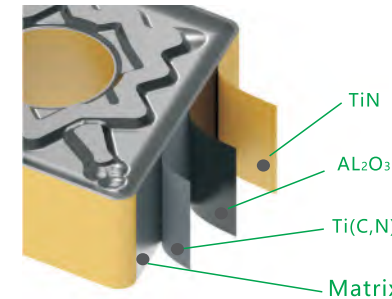

Wear status recognition layer, yellow coating makes it easier to observe the wear of the front and rear cutting surfaces of the insert.  
 Excellent heat insulation and high temperature resistance layer, especially suitable for high-speed processing.  
 Stronger wear resistance and high-temperature stability can significantly improve tool life.  
 The matrix is designed specifically for steel processing, reduced the defects in alloys and improves the toughness of inserts.

#### The Intro of CVD Grades

##### VK4415 ISO:P05-P20

- ◆ Medium temperature CVD coating, used for finishing to semi-finishing turning of steel, continuous and light intermittent processing;
- ◆ Excellent wear resistance enables long service life processing at high speed under good working conditions.

##### VK4420 ISO:P10-P25

- ◆ High wear resistance, good red hardness under high-temperature, recommended for continuous cutting and slight intermittent cutting
- ◆ Key recommendation for continuous roughing of large workpieces

##### VK4425 ISO:P15-P35

- ◆ Medium temperature CVD coating, with both wear resistance and toughness, recommended for continuous and intermittent processing.
- ◆ The first recommended grade for steel parts processing.

#### The Application of CVD Grades

Workpiece	P					M					S							
	Wearness ← Toughness					Wearness ← Toughness					Wearness ← Toughness							
ISO	01	10	20	30	40	50	01	10	20	30	40	50	01	10	20	30	40	50
CVD Grades	VK4415					VK4420					VK4425							

#### Case

Info	Import T Company	WecoTool
Lathe	Horizontal CNC lathe	
Workpiece material	55#	
Hardness	HB200-240	
Workpiece	M40 mm11	
Processing type	Intermittent roughing	
Cutter	WFLN2525 308	
Insert	FNMG080412-M T4925	FNMG080412-AM VK4425
Cutting Parameter		
Vc (m/min)	180-300	180-300
F (mm/rev)	0.2-0.3	0.2-0.3
ap (mm)	1.0-1.5	1.0-1.5
Cooling Type	External cooling emulsion	
Test Result		
pcs/edge	70-75	70-75
Processing Time (min)		
VB (mm)	0.31	0.32

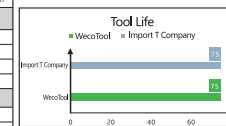

✓ Conclusion: The processing life is basically the same.

Info	Domestic Z Company	WecoTool
Lathe	Horizontal CNC lathe	
Workpiece material	Gr15	
Hardness	HB180-220	
Workpiece	Bearing Ring	
Processing type	External semi-finishing of continuous turning	
Cutter	PFLM2525 308	
Insert	FNMG080408-M T4C15+	FNMG080408-AM VK4415
Cutting Parameter		
Vc (m/min)	360	360
F (mm/rev)	0.25	0.25
ap (mm)	2	2
Cooling Type	External cooling	
Test Result		
pcs/edge	30 blade	40 blade
Processing Time (min)		
VB (mm)	0.31	0.32

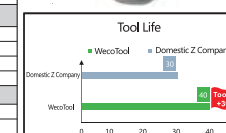

✓ Conclusion: Increase processing life by 30%.

## The Features of CVD Coating

ISO	Grade	Colour	Coating Structure		Electron Microscopy Images	Features.Application
<b>K Cast Iron</b>	VK3020	Black	TiCN+Al <sub>2</sub> O <sub>3</sub>			High hardness matrix, thinned CVD coating, excellent wear resistance.Milling gray cast iron and ductile iron under stable working conditions.
	VK3040	Black	TiCN+Al <sub>2</sub> O <sub>3</sub>			High toughness matrix, thinned CVD coating, excellent resistance to chipping.Rough milling of cast iron, especially in harsh working conditions.
	VK3115	Black	TiCN+Al <sub>2</sub> O <sub>3</sub>			Optimized and extremely wear-resistant material, nano thick film CVD coating.Continuous or light intermittent turning of gray cast iron and ductile iron.
<b>P Steel</b>	VK4215	Yellow Black	TiCN+Al <sub>2</sub> O <sub>3</sub> + ( TiN )			Wear-resistant substrate with resistance to plastic deformation, strong and tough coating with excellent bonding force.High-speed, high-efficiency turning of finishing-roughing steel.
	VK4225	Yellow Black	TiCN+Al <sub>2</sub> O <sub>3</sub> + ( TiN )			A matrix with both wear resistance and chipping resistance, and a tough coating with excellent adhesion.The first choice for Intermittent - general turning of steel.
	VK4435	Yellow Black	TiCN+Al <sub>2</sub> O <sub>3</sub> + ( TiN )			High toughness matrix, strong and tough coating with excellent bonding force, extremely high processing safetyHeavy-duty machining of steel and interrupted turning.
	<b>NEW</b> VK4415	Yellow Black	TiCN+Al <sub>2</sub> O <sub>3</sub> +TiN			High toughness matrix, strong and tough coating with excellent bonding strength, and extremely high processing safety.Heavy load machining and intermittent turning of steel parts.
	<b>NEW</b> VK4425	Yellow Black	TiCN+Al <sub>2</sub> O <sub>3</sub> +TiN			Upgraded product performance, with a matrix that combines wear resistance and blade collapse resistance, and a strong and tough coating with excellent bonding strength, the resistance to plastic deformation and crescent pit wear is improved.Longer lifespan for intermittent-general turning steel parts, also for heavy-duty machining.





## The Features of PVD Coating

ISO	Grade	Colour	Coating Structure		Electron Microscopy Images	Features.Application
P Steel	VK1015	Black	AlTiN			Submicron matrix resistant to abrasive wear and a coating with higher aluminum content. Stable milling of cast iron and steel parts.
	VK1025	Black	AlTiN			The Matrix balances hardness and toughness, and the coating with higher aluminum content. Suitable for general milling of cast iron, steel, and stainless steel, with high processing safety.
	VK1825	Bronze	AlTiMeN			Ultra fine grain matrix, newly upgraded nano composite coating with high heat resistance and high toughness. Suitable for general milling of cast iron, steel, and stainless steel, with superior wear resistance. Additional grade for stainless steel turning.
M Stainless Steel	VK1820	Bronze	AlTiMeN			Medium cobalt and ultra fine grain hard alloy matrix. High hardness nano composite PVD coating. The perfect fusion of high-strength, high toughness matrix and wear-resistant surface coating, comprehensive excellent performance.
	VK1824	Bronze	AlTiMeN			Special ultra-fine grain matrix with enhanced toughness and red hardness, and the latest high wear-resistant coating. General high-performance machining for efficient milling of steel, stainless steel, and heat-resistant alloys, as well as for stainless steel turning.
	VK1525	Purple Black	AlTiMeN			Nano multilayer coating with ultra-fine grain matrix, good wear resistance and oxidation resistance. Stable and long-life milling of steel and stainless steel.
	VK1828	Bronze	AlTiMeN			Submicron matrix, newly upgraded nano composite coating with high heat resistance and toughness. Preferred grade for stainless steel turning, supplementary machining of softer steel.
S Heat Resistant Alloy	VK1605	Bronze	AlTiSiN			Low cobalt, fine-grained wear-resistant and heat-resistant matrix. High hardness coatings deposited by high-energy pulse magnetron sputtering, with higher coating adhesion and has good wear resistance and heat resistance. Suitable for high-temperature alloy and titanium alloy turning, continuous and stable working conditions processing;
	VR1610	Bronze	AlTiSiN			Superfine grain matrix reinforced with adhesive phase, excellent heat resistance and wear resistance. The high hardness coating deposited by HIPIMS has higher coating adhesion and good wear resistance and heat resistance. Suitable for finishing – semi-finishing turning of heat-resistant alloys and high hardness materials, and general milling.
	VR1525	Purple Black	AlTiMeN			Superfine grain matrix optimized for heat resistance and toughness of heat-resistant alloys, with wear resistance and oxidation resistance. Good nano multilayer coating. The preferred grade for general machining of heat-resistant alloys.
	VR1029	Black	AlTiN			Specially reinforced super tough matrix, high aluminum coating, higher cost-effectiveness. Efficient rough milling for steam turbine blades, long-life dry cutting, and also suitable for heat resistance Alloy.





## Recommended Turning Insert Grade

	ISO	CVD		PVD	
<b>K</b> Cast Iron	01				
	10		VK3115		
	20				
	30				
	40				
<b>P</b> Steel	01	VK4215		VK4415	
	10		VK4225		VK4425
	20			VK4435	
	30				
	40				
<b>M</b> Stainless Steel	01				Vk1820
	10				
	20				Vk1824
	30				Vk1525
	40				Vk1828
<b>S</b> Heat Resistant Alloy	01				
	10			VK1605	VR1610
	20				
	30			VK1824	
	40				VR1525



## General Turning Insert

Item No.	Application	Chipbreaker	Feature/Shape of Insert
1	Steel Finishing	AF	P-type Material Finishing
			M-level double-sided chipbreaker, two-stage bump effect for stable chip handling in a wide range of feeds.
2	Steel Semi-finishing	AS	P-type Material Semi-finishing
			M-level double-sided chipbreaker, negative chamfer design, high edge strength, suitable for semi-finishing occasions with unstable working conditions.
3	Steel Medium machining	AM	P-type Material Medium machining
			Low cutting resistance due to double-angle cutting edge design, variable width design for sharpness and strength.
4	Steel Roughing	AG	P-type Material Roughing
			The preferred chip breaker for lightload roughing, wide margin design, good edge strength, high metal removal rate, good wear resistance and cutting life.
5	Steel Heavy-duty	AG (Single Side)	P-type Material Heavy-duty
			M-level single-sided chipbreaker, negative chamfer design, under the large cutting depth and large feed processing parameters, high edge strength and high metal removal rate can be obtained.



## General Turning Insert

Item No.	Application	Chipbreaker	Feature/Shape of Insert
6	Stainless steel finishing	BF	M type material finishing
			M-level double-sided chipbreaker, small edge width + double positive rake angle, sharp blade edge, low cutting resistance, special edge inclination design, can obtain high-quality machined surface.
7	Stainless steel semi-finishing	BM	M type material semi-finishing
			M-level double-sided chipbreaker, double positive rake angle, higher edge strength, widely application for the general processing of stainless steel.
8	Stainless steel roughing	BR	M type material roughing
			M-level double-sided chipbreaker, variable blade width and variable rake angle design, suitable for semi-finishing and roughing of stainless steel
9	High temperature alloy semi-finishing	DM	S type material semi-finishing
			M-level double-sided chipbreaker. Adopting the double positive rake angle combines the sharpness and strength of the insert; the cutting resistance is small, and the wider chipbreaker ensures enough space for chip deformation, reducing groove wear.

## General Inner Hole Turning Insert

Item No.	Application	Chipbreaker	Feature/Shape of Insert
10	General semi-finishing	GM	General chipbreaker
			M-level single-sided chipbreaker, suitable for semi-finishing of inner holes and outer circles of P, M and K type materials
11	Stainless steel finishing	GF	M type material finishing
			M-level single-sided chipbreaker, suitable for innerhole and outer circle finishing of stainless steel.
12	High temperature alloy semi-finishing	DM	S type material finishing
			M-level single-sided chipbreaker, suitable for innerhole and outer circle semi-finishing of S type and M type material.

## Special Turning Insert

Item No.	Application	Chipbreaker	Feature/Shape of Insert
13	Train wheel hub machining	175.32 series	Chipbreaker for finishing of P type material
			M-level double-sided chipbreaker, vertical cutting inserts, especially suitable for the trimming of train wheels.
14		RCMX series	Chipbreaker for heavy-load machining of P type material
			M-level single-sided chipbreaker, negative chamfer design, high edge strength, first choice for profiling.

## Recommendation of Inserts and Chip Breakers

Finishing						
	CNMG-AF	DNMG-AF	SNMG-AF	TNMG-AF	VNMG-AF	WNMG-AF
Length	09/12	11/15	12	16/22	16	06/08
Page	A-27	A-38	A-47	A-58	A-68	A-75
Finishing						
	CNMG-BF	DNMG-BF	SNMG-BF	TNMG-BF	VNMG-BF	WNMG-BF
Length	09/12	15	12	16	16	06/08
Page	A-32	A-42	A-52	A-62	A-71	A-79
Semi-finishing						
	CNMG-AS	CNMG-AM	CNMG-BM	CNMG-CM	CNMA	CNMG-DM
Length	12/16/19	12/16/19	12/16	12/16	12/16/19	12
Page	A-28	A-29	A-33	A-35	A-36	A-37
Semi-finishing						
	DNMG-AS	DNMG-AM	DNMG-BM	DNMG-CM	DNMG-DM	SNMG-AS
Length	15	15	15	15	15	12/15
Page	A-39	A-40	A-43	A-45	A-46	A-48
Semi-finishing						
	SNMG-AM	SNMG-BM	SNMG-CM	SNMA	SNMG-DM	TNMG-AS
Length	12/15	12/15	12/16	12/15/19	12/15	16/22
Page	A-49	A-53	A-55	A-56	A-57	A-59

Semi-finishing						
	TNMG-AM	TNMG-BM	TNMG-CM	TNMA	VNMG-AS	VNMG-AM
Length	16/22	16/22	16	16/22	11/16	11/16
Page	A-60	A-63	A-65	A-66	A-69	A-70
Semi-finishing						
	VNMG-CM	WNMG-AS	WNMG-AM			
Length	16	08	08			
Page	A-73	A-76	A-77			
Roughing						
	WNMG-BM	WNMG-CM	WNMA	WNMG-DM	CNMG-AG	CNMG-BR
Length	06/08	06/08	08	08	12/16/19	12/16
Page	A-80	A-82	A-83	A-84	A-30	A-34
Roughing						
	DNMG-AG	DNMG-BR	SNMG-AG	SNMG-BR		
Length	15	15	12/15/19	12/15		
Page	A-41	A-44	A-50	A-54		
Heavy-duty						
	TNMG-AG	TNMG-BR	WNMG-AG	WNMG-BR	CNMM-AG	
Length	16/22	16/22	06/08	06/08	19/25	
Page	A-61	A-64	A-78	A-81	A-31	

## Recommendation of Inserts and Chip Breakers

Semi-finishing						
	SNMM-AG	CCMT-GM	DCMT-GM	SCMT-GM	TCMT-GM	
Length	19/25	06/09/12	07/11	09/12	09/11/16	
Page	A-51	A-85	A-87	A-89	A-91	
M Finishing						
	CCMT-GF	DCMT-GF	SCMT-GF	TCMT-GF		
Length	06, 09	07, 11	09	09, 11, 16		
Page	A-86	A-88	A-90	A-92		
<b>NEW</b> Small Parts Machining						
	TNGG-FS	VNGG-FS	DCGT-FS	VBGT-FS	VCGT-FS	
Length	11	16	11	11	11	
Page	A-94	A-95	A-96	A-97	A-98	
GRINDED Small Parts Machining						
	CCGT-UF	DCGT-UF	TCGT-UF	VCGT-UF		
Length	09	07, 11	11	08, 11		
Page	A-99	A-100	A-101	A-102		
GRINDED Small Parts Machining						
	TNGG-F	TNGG-M	TPGH			
Length	16	16	08, 09, 11			
Page	A-103	A-104	A-105			

High temperature alloy Semi-finishing						
	CCMT-DM	DCMT-DM	SCMT-DM	TCMT-DM		
Length	12	07, 11	09	11		
Page	A-106	A-107	A-108	A-109		
Train Wheel Hub Machining						
	RCMX	175.32-22	175.32-24	175.32-28		
Length	08-32	19	19	19		
Page	A-110	A-111	A-112	A-113		
<b>NEW</b> Parting and Grooving						
	EDMN-C	EDMN-J	ECMN-T	ERMN-T	MGGN-GL	ERMN-M
Length	2.0-5.0	2.0-5.0	3.0-6.0	3.0-6.0	2.0-5.0	2.0-8.0
Page	A-117	A-118	A-119	A-120	A-121	A-122
GRINDED Grooving						
	TGF32R/L	GBA43R/L	TKF12R/L	TKF16R/L		
Length	1.1-3.0	1.25-3.0	0.5-2.0	1.5-2.0		
Page	A-124	A-125	A-127	A-128		





### Negative Inserts

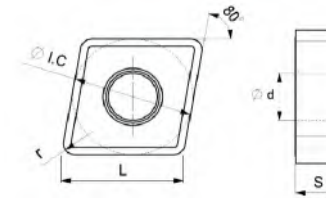

Length	Size(mm)			
	IC	S	d	r
9	9.525	3.18	3.81	0.4-0.8
12	12.7	4.76	5.16	0.4-1.2

80° CN□□ With Hole

Shape	Type	ap (mm)	f (mm/rev)	Grade													
				CVD						PVD							
				VK3020	VK3040	VK3115	VK4415	VK4425	VK4435	VK1025	VK1525	VK1825	VK1824	VK1828	VR1610	VR1525	
	CNMG090304-AF	0.10-1.50	0.04-0.20				●	○									
	CNMG090308-AF	0.20-2.00	0.08-0.25				●	○									
	CNMG120404-AF	0.10-1.50	0.04-0.20				●	○									
	CNMG120408-AF	0.20-2.00	0.08-0.25				●	○									
	CNMG120412-AF	0.50-2.50	0.10-0.25				●	○									
P Finishing																	

Note: ●Recommended grade ready to stock

## Negative Inserts

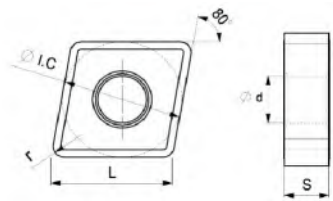

Length	Size(mm)			
	IC	S	d	r
12	12.7	4.76	5.16	0.4-1.6
16	15.875	6.35	6.35	0.8-1.6
19	19.05	6.35	7.94	0.8-1.6

80° CN□□ With Hole

Shape	Type	ap (mm)	f (mm/rev)	Grade																		
				CVD						PVD												
				VK3020	VK3040	VK3115	VK4415	VK4425	VK4435	VK1025	VK1525	VK1825	VK1824	VK1828	VR1610	VR1525						
P Semi-finishing	CNMG120404-AS	0.50-4.00	0.16-0.25				○	●	○													
	CNMG120408-AS	0.60-5.00	0.18-0.40				○	●	○													
	CNMG120412-AS	1.00-5.00	0.20-0.45				○	●	○													
	CNMG120416-AS	1.20-5.00	0.25-0.50				○	●	○													
	CNMG160608-AS	0.80-7.00	0.25-0.40				○	●	○													
	CNMG160612-AS	1.00-7.00	0.30-0.50				○	●	○													
	CNMG160616-AS	1.20-7.00	0.35-0.55				○	●	○													
	CNMG190608-AS	0.80-8.00	0.30-0.45				○	●	○													
	CNMG190612-AS	1.00-8.00	0.40-0.55				○	●	○													
	CNMG190616-AS	1.20-8.00	0.45-0.60				○	●	○													

Note: ●Recommended grade ready to stock

## Negative Inserts

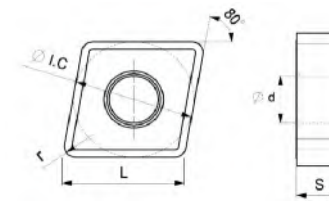

Length	Size(mm)			
	IC	S	d	r
12	12.7	4.76	5.16	0.4-1.6
16	15.875	6.35	6.35	0.8-1.6
19	19.05	6.35	7.94	0.8-1.6

80° CN□□ With Hole

Shape	Type	ap (mm)	f (mm/rev)	Grade																		
				CVD						PVD												
				VK3020	VK3040	VK3115	VK4415	VK4425	VK4435	VK1025	VK1525	VK1825	VK1824	VK1828	VR1610	VR1525						
P Medium machining	CNMG120404-AM	0.40-5.50	0.10-0.30				○	●	○													
	CNMG120408-AM	0.50-5.50	0.15-0.50				○	●	○													
	CNMG120412-AM	0.80-5.50	0.18-0.60				○	●	○													
	CNMG120416-AM	1.00-5.50	0.23-0.65				○	●	○													
	CNMG160608-AM	0.50-7.20	0.15-0.50				○	●	○													
	CNMG160612-AM	0.80-7.20	0.18-0.60				○	●	○													
	CNMG160616-AM	1.00-7.20	0.23-0.65				○	●	○													
	CNMG190608-AM	0.50-8.60	0.15-0.50				○	●	○													
	CNMG190612-AM	0.80-8.60	0.18-0.60				○	●	○													
								○	●	○												

Note: ●Recommended grade ready to stock

## Negative Inserts

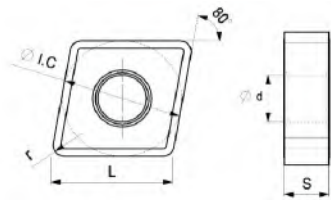

Length	Size(mm)			
	IC	S	d	r
12	12.7	4.76	5.16	0.8-1.6
16	15.875	6.35	6.35	0.8-1.6
19	19.05	6.35	7.94	0.8-2.4

80° CN□□ With Hole

Shape	Type	ap (mm)	f (mm/rev)	Grade																		
				CVD						PVD												
				VK3020	VK3040	VK3115	VK4415	VK4425	VK4435	VK1025	VK1525	VK1825	VK1824	VK1828	VR1610	VR1525						
 P Roughing	CNMG120408-AG	0.80-6.00	0.20-0.40				○	●	●													
	CNMG120412-AG	1.00-6.00	0.25-0.60				○	●	●													
	CNMG120416-AG	1.60-6.00	0.35-0.70				○	●	●													
	CNMG160608-AG	1.00-8.00	0.25-0.50				○	●	●													
	CNMG160612-AG	1.20-8.00	0.35-0.65				○	●	●													
	CNMG160616-AG	1.60-8.00	0.40-0.70				○	●	●													
	CNMG190608-AG	1.00-10.00	0.25-0.50				○	●	●													
	CNMG190612-AG	1.20-10.00	0.30-0.70				○	●	●													
	CNMG190616-AG	1.60-10.00	0.35-0.80				○	●	●													
	CNMG190624-AG	2.00-10.00	0.45-1.00				○	●	●													

Note: ●Recommended grade ready to stock

## Negative Inserts

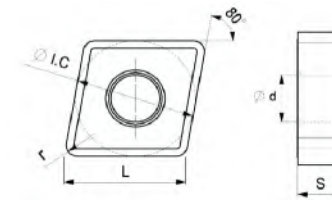

Length	Size(mm)			
	IC	S	d	r
19	19.05	6.35	7.94	1.2-2.4
25	25.4	7.94-9.52	9.12	2.4-3.2

80° CN□□ With Hole

Shape	Type	ap (mm)	f (mm/rev)	Grade																	
				CVD						PVD											
				VK3020	VK3040	VK3115	VK4415	VK4425	VK4435	VK1025	VK1525	VK1825	VK1824	VK1828	VR1610	VR1525					
 P Heavy-duty	CNMM190612-AG	2.00-13.00	0.50-1.00				○	●	●												
	CNMM190616-AG	2.50-13.00	0.50-1.10				○	●	●												
	CNMM190624-AG	3.00-13.00	0.60-1.60				○	●	●												
	CNMM250724-AG	3.00-17.00	0.60-1.60				○	●	●												
	CNMM250924-AG	3.00-17.00	0.60-1.60				○	●	●												
	CNMM250932-AG	3.50-17.00	0.70-2.00				○	●	●												

Note: ●Recommended grade ready to stock



## Negative Inserts

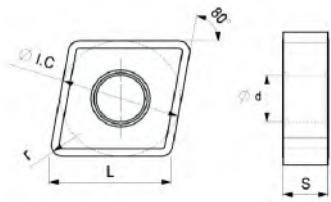

Length	Size(mm)			
	IC	S	d	r
12	12.7	4.76	5.16	0.4-1.2
16	15.875	6.35	6.35	0.8-1.6

80° CN□□ With Hole

Shape	Type	ap (mm)	f (mm/rev)	Grade																				
				CVD							PVD													
				VK3020	VK3040	VK3115	VK4415	VK4425	VK4435	VK1025	VK1525	VK1825	VK1824	VK1828	VR1610	VR1525								
 M Roughing	CNMG120404-BR	0.80-5.00	0.15-0.35							○	○													
	CNMG120408-BR	1.20-5.00	0.20-0.40							○	○													
	CNMG120412-BR	1.50-5.00	0.25-0.50							○	○													
	CNMG160608-BR	1.20-7.00	0.22-0.45							○	○													
	CNMG160612-BR	1.50-7.00	0.25-0.60							○	○													
	CNMG160616-BR	2.00-7.00	0.30-0.65							○	○													

Note: ●Recommended grade ready to stock

## Negative Inserts

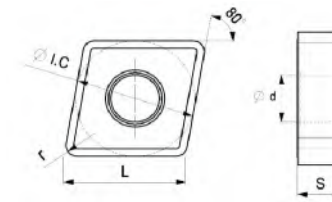

Length	Size(mm)			
	IC	S	d	r
12	12.7	4.76	5.16	0.4-1.6
16	15.875	6.35	6.35	0.8-1.6
19	19.05	6.35	7.94	0.8-1.6

80° CN□□ With Hole

Shape	Type	ap (mm)	f (mm/rev)	Grade																				
				CVD							PVD													
				VK3020	VK3040	VK3115	VK4415	VK4425	VK4435	VK1025	VK1525	VK1825	VK1824	VK1828	VR1610	VR1525								
 K Semi-finishing	CNMG120404-CM	0.60-5.00	0.16-0.25																					
	CNMG120408-CM	0.80-5.00	0.25-0.50																					
	CNMG120412-CM	1.20-5.00	0.30-0.50																					
	CNMG160612-CM	1.20-7.00	0.30-0.60																					
	CNMG160616-CM	1.50-7.00	0.35-0.60																					
	CNMG190612-CM	1.20-8.00	0.30-0.65																					

Note: ●Recommended grade ready to stock

## Negative Inserts

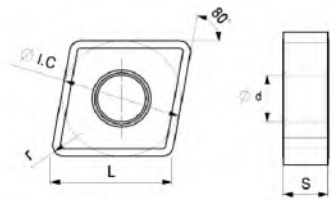

Length	Size(mm)			
	IC	S	d	r
12	12.7	4.76	5.16	0.4-1.6
16	15.875	6.35	6.35	1.2-1.6
19	19.05	6.35	7.94	1.2-1.6

80° CN□□ With Hole

Shape	Type	ap (mm)	f (mm/rev)	Grade													
				CVD						PVD							
				VK3020	VK3040	VK3115	VK4415	VK4425	VK4435	VK1025	VK1525	VK1825	VK1824	VK1828	VR1610	VR1525	
K Roughing	CNMA120404	0.60-5.00	0.16-0.25			●	○	○									
	CNMA120408	0.80-5.00	0.25-0.50			●	○	○									
	CNMA120412	1.20-5.00	0.30-0.50			●	○	○									
	CNMA120416	1.50-5.00	0.35-0.70			●	○	○									
	CNMA160612	1.20-7.00	0.35-0.70			●	○	○									
	CNMA160616	1.50-7.00	0.35-0.80			●	○	○									
	CNMA190612	1.20-8.00	0.30-0.65			●	○	○									
	CNMA190616	1.50-8.00	0.35-0.80			●	○	○									

Note: ● Recommended grade ready to stock

## Negative Inserts

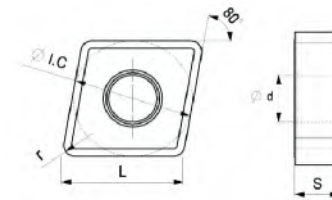

Length	Size(mm)			
	IC	S	d	r
12	12.7	4.76	5.16	0.4-0.8
16	15.875	6.35	6.35	0.8-1.6
19	19.05	6.35	7.94	0.8-1.6

80° CN□□ With Hole

Shape	Type	ap (mm)	f (mm/rev)	Grade													
				CVD				PVD									
				VK3115	VK4415	VK4425	VK4435	VK1025	VK1525	VK1825	VK1824	VK1828	VK1605	VR1510	VR1610	VR1525	
S Medium- Rough Machining	CNMG120404-DM	0.80-5.00	0.15-0.35							○			○		●	○	●
	CNMG120408-DM	1.20-5.00	0.20-0.40							○			○		●	○	●
	CNMG120412-DM	1.50-5.00	0.25-0.50							○			○		●	○	●
	CNMG120416-DM	2.00-5.00	0.30-0.55							○			○		●	○	●
	CNMG160608-DM	1.20-7.00	0.22-0.45							○			○		●	○	●
	CNMG160612-DM	1.50-7.00	0.25-0.60							○			○		●	○	●
	CNMG160616-DM	2.00-7.00	0.30-0.65							○			○		●	○	●
	CNMG190608-DM	1.20-8.00	0.22-0.45							○			○		●	○	●
CNMG190612-DM	1.50-8.00	0.25-0.60							○			○		●	○	●	
CNMG190616-DM	2.00-8.00	0.30-0.80							○			○		●	○	●	

Note: ● Recommended grade ready to stock

## Negative Inserts

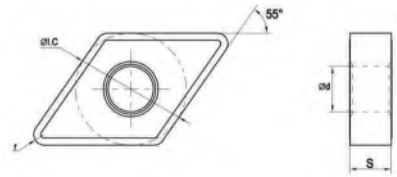

Length	Size(mm)			
	IC	S	d	r
15	12.7	4.76	5.16	0.8-1.2
15	12.7	6.35	5.16	0.4-1.2

55° DN□□ With Hole

Shape	Type	ap (mm)	f (mm/rev)	Grade																			
				CVD						PVD													
				VK3020	VK3040	VK3115	VK4415	VK4425	VK4435	VK1025	VK1525	VK1825	VK1824	VK1828	VR1610	VR1525							
P Finishing	DNMG150404-AF	0.10-1.50	0.05-0.20				●	○															
	DNMG150408-AF	0.20-2.00	0.08-0.25				●	○															
	DNMG150412-AF	0.50-2.50	0.10-0.25				●	○															
	DNMG150604-AF	0.10-1.50	0.05-0.20				●	○															
	DNMG150608-AF	0.20-2.00	0.08-0.25				●	○															
	DNMG150612-AF	0.50-2.50	0.10-0.25				●	○															

Note: ●Recommended grade ready to stock

## Negative Inserts

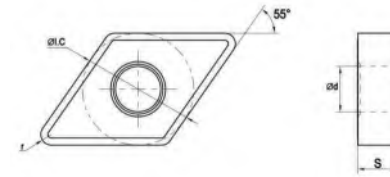

Length	Size(mm)			
	IC	S	d	r
15	12.7	4.76-6.35	5.16	0.4-1.2

55° DN□□ With Hole

Shape	Type	ap (mm)	f (mm/rev)	Grade																		
				CVD						PVD												
				VK3020	VK3040	VK3115	VK4415	VK4425	VK4435	VK1025	VK1525	VK1825	VK1824	VK1828	VR1610	VR1525						
P Semi-finishing	DNMG150404-AS	0.50-4.00	0.16-0.25				○	●	○													
	DNMG150408-AS	0.60-5.00	0.18-0.35				○	●	○													
	DNMG150412-AS	1.00-5.00	0.20-0.40				○	●	○													
	DNMG150604-AS	0.50-4.00	0.16-0.25				○	●	○													
	DNMG150608-AS	0.60-5.00	0.18-0.35				○	●	○													
	DNMG150612-AS	1.00-5.00	0.20-0.40				○	●	○													

Note: ●Recommended grade ready to stock

## Negative Inserts

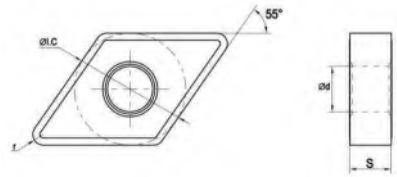

Length	Size(mm)			
	IC	S	d	r
15	12.7	4.76-6.35	5.16	0.4-1.2

55° DN□□ With Hole

Shape	Type	ap (mm)	f (mm/rev)	Grade																			
				CVD						PVD													
				VK3020	VK3040	VK3115	VK4415	VK4425	VK4435	VK1025	VK1525	VK1825	VK1824	VK1828	VR1610	VR1525							
 P Medium machining	DNMG150404-AM	0.40-6.00	0.10-0.3				○	●	○														
	DNMG150408-AM	0.50-6.00	0.15-0.5				○	●	○														
	DNMG150412-AM	0.80-6.00	0.18-0.6				○	●	○														
	DNMG150604-AM	0.40-6.00	0.10-0.3				○	●	○														
	DNMG150608-AM	0.50-6.00	0.15-0.5				○	●	○														
	DNMG150612-AM	0.80-6.00	0.18-0.6				○	●	○														

Note: ●Recommended grade ready to stock

## Negative Inserts

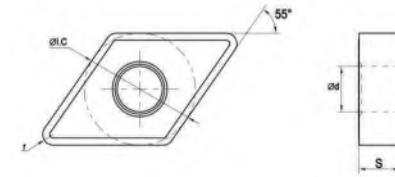

Length	Size(mm)			
	IC	S	d	r
15	12.7	4.76-6.35	5.16	0.8-1.2

55° DN□□ With Hole

Shape	Type	ap (mm)	f (mm/rev)	Grade																			
				CVD						PVD													
				VK3020	VK3040	VK3115	VK4415	VK4425	VK4435	VK1025	VK1525	VK1825	VK1824	VK1828	VR1610	VR1525							
 P Roughing	DNMG150408-AG	0.80-5.00	0.18-0.35				○	●	●														
	DNMG150412-AG	1.00-5.00	0.20-0.40				○	●	●														
	DNMG150608-AG	0.80-5.00	0.15-0.35				○	●	●														
	DNMG150612-AG	1.00-5.00	0.20-0.55				○	●	●														

Note: ●Recommended grade ready to stock

## Negative Inserts

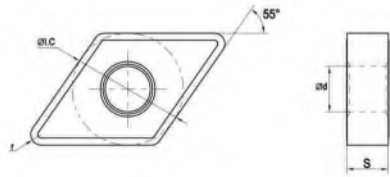

Length	Size(mm)			
	IC	S	d	r
15	12.7	4.76-6.35	5.16	0.4-1.2

55° DN□□ With Hole

Shape	Type	ap (mm)	f (mm/rev)	Grade													
				CVD							PVD						
				VK3020	VK3040	VK3115	VK4415	VK4425	VK4435	VK1025	VK1525	VK1825	VK1824	VK1828	VR1610	VR1525	
	DNMG150404-BF	0.20-1.50	0.05-0.15								○	●	○	●			
	DNMG150408-BF	0.40-1.50	0.07-0.20								○	●	○	●			
	DNMG150412-BF	0.50-2.00	0.10-0.25								○	●	○	●			
	DNMG150604-BF	0.20-1.50	0.05-0.15								○	●	○	●			
	DNMG150608-BF	0.40-1.50	0.07-0.20								○	●	○	●			
	DNMG150612-BF	0.50-2.00	0.10-0.25								○	●	○	●			
M Finishing																	

Note: ●Recommended grade ready to stock

## Negative Inserts

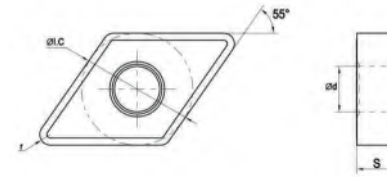

Length	Size(mm)			
	IC	S	d	r
15	12.7	4.76-6.35	5.16	0.4-1.2

55° DN□□ With Hole

Shape	Type	ap (mm)	f (mm/rev)	Grade																
				CVD							PVD									
				VK3020	VK3040	VK3115	VK4415	VK4425	VK4435	VK1025	VK1525	VK1825	VK1824	VK1828	VR1610	VR1525				
	DNMG150404-BM	0.50-2.50	0.10-0.18												○	○	○	●		
	DNMG150408-BM	0.80-3.00	0.15-0.25												○	○	○	●		
	DNMG150412-BM	0.80-3.00	0.18-0.30												○	○	○	●		
	DNMG150604-BM	0.50-2.50	0.10-0.18												○	○	○	●		
	DNMG150608-BM	0.80-3.00	0.15-0.25												○	○	○	●		
	DNMG150612-BM	0.80-3.00	0.18-0.30												○	○	○	●		
M Semi-finishing																				

Note: ●Recommended grade ready to stock

## Negative Inserts

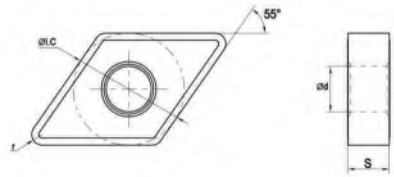

Length	Size(mm)			
	IC	S	d	r
15	12.7	4.76-6.35	5.16	0.4-1.2

55° DN□□ With Hole

Shape	Type	ap (mm)	f (mm/rev)	Grade													
				CVD							PVD						
				VK3020	VK3040	VK3115	VK4415	VK4425	VK4435	VK1025	VK1525	VK1825	VK1824	VK1828	VR1610	VR1525	
	DNMG150404-BR	0.80-4.00	0.15-0.35							○	○			○	●		
	DNMG150408-BR	1.20-4.00	0.20-0.40							○	○			○	●		
	DNMG150412-BR	1.50-4.00	0.25-0.50							○	○			○	●		
	DNMG150604-BR	0.80-4.00	0.15-0.35							○	○			○	●		
	DNMG150608-BR	1.20-4.00	0.20-0.40							○	○			○	●		
	DNMG150612-BR	1.50-4.00	0.25-0.50							○	○			○	●		
M Roughing																	

Note: ●Recommended grade ready to stock

## Negative Inserts

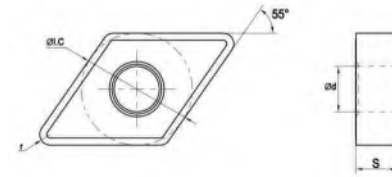

Length	Size(mm)			
	IC	S	d	r
15	12.7	6.35	5.16	0.8-1.2

55° DN□□ With Hole

Shape	Type	ap (mm)	f (mm/rev)	Grade													
				CVD							PVD						
				VK3020	VK3040	VK3115	VK4415	VK4425	VK4435	VK1025	VK1525	VK1825	VK1824	VK1828	VR1610	VR1525	
	DNMG150404-CM	0.60-5.00	0.15-0.30			●	○	○									
	DNMG150408-CM	0.80-5.00	0.20-0.45			●	○	○									
	DNMG150412-CM	1.20-5.00	0.25-0.45			●	○	○									
	DNMG150604-CM	0.60-5.00	0.15-0.30			●	○	○									
	DNMG150608-CM	0.80-5.00	0.25-0.45			●	○	○									
	DNMG150612-CM	1.20-5.00	0.30-0.45			●	○	○									
K Semi-finishing																	

Note: ●Recommended grade ready to stock



## Negative Inserts

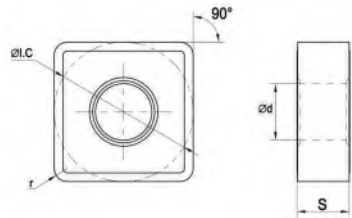

Length	Size(mm)			
	IC	S	d	r
12	12.7	4.76	5.16	0.8-1.6
15	15.875	6.35	6.35	0.8-1.2

90° SN□□ With Hole

Shape	Type	ap (mm)	f (mm/rev)	Grade														
				CVD							PVD							
				VK3020	VK3040	VK3115	VK4415	VK4425	VK4435	VK1025	VK1525	VK1825	VK1824	VK1828	VR1610	VR1525		
 P Semi-finishing	SNMG120404-AS	0.50-4.00	0.16-0.25				○	●	○									
	SNMG120408-AS	0.60-5.00	0.18-0.40				○	●	○									
	SNMG120412-AS	1.00-5.00	0.20-0.45				○	●	○									
	SNMG150612-AS	1.00-8.00	0.30-0.50				○	●	○									

Note: ●Recommended grade ready to stock

## Negative Inserts

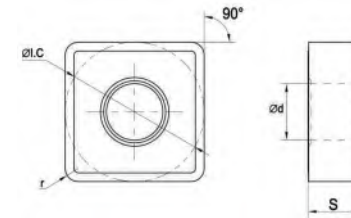

Length	Size(mm)			
	IC	S	d	r
12	12.7	4.76	5.16	0.8-1.6
15	15.875	6.35	6.35	0.8-1.2

90° SN□□ With Hole

Shape	Type	ap (mm)	f (mm/rev)	Grade														
				CVD							PVD							
				VK3020	VK3040	VK3115	VK4415	VK4425	VK4435	VK1025	VK1525	VK1825	VK1824	VK1828	VR1610	VR1525		
 P Medium machining	SNMG120404-AM	0.40-6.00	0.10-0.3				○	●	○									
	SNMG120408-AM	0.50-6.00	0.15-0.5				○	●	○									
	SNMG120412-AM	0.80-6.00	0.18-0.6				○	●	○									
	SNMG150612-AM	0.80-7.50	0.18-0.6				○	●	○									

Note: ●Recommended grade ready to stock

## Negative Inserts

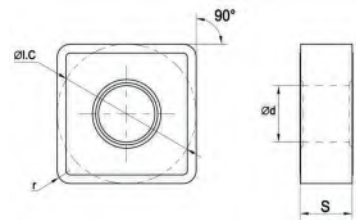

Length	Size(mm)			
	IC	S	d	r
12	12.7	4.76	5.16	0.8-1.6
15	15.875	6.35	6.35	0.8-1.2
19	19.05	6.35	7.94	1.2-1.6

90° SN□□ With Hole

Shape	Type	ap (mm)	f (mm/rev)	Grade																		
				CVD						PVD												
				VK3020	VK3040	VK3115	VK4415	VK4425	VK4435	VK1025	VK1525	VK1825	VK1824	VK1828	VR1610	VR1525						
 P Roughing	SNMG120408-AG	0.80-6.00	0.20-0.55				○	●	●													
	SNMG120412-AG	1.00-6.00	0.25-0.65				○	●	●													
	SNMG120416-AG	1.60-6.00	0.35-0.75				○	●	●													
	SNMG150612-AG	1.20-8.00	0.25-0.70				○	●	●													
	SNMG190612-AG	1.20-10.00	0.30-0.70				○	●	●													
	SNMG190616-AG	1.60-10.00	0.35-0.80				○	●	●													

Note: ●Recommended grade ready to stock

## Negative Inserts

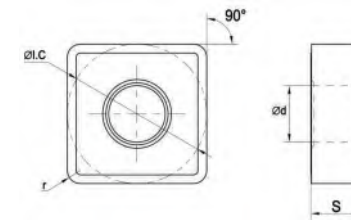

Length	Size(mm)			
	IC	S	d	r
19	19.05	6.35	7.94	1.2-2.4
25	25.4	7.94-9.52	9.12	2.4-3.2

90° SN□□ With Hole

Shape	Type	ap (mm)	f (mm/rev)	Grade																		
				CVD						PVD												
				VK3020	VK3040	VK3115	VK4415	VK4425	VK4435	VK1025	VK1525	VK1825	VK1824	VK1828	VR1610	VR1525						
 P Heavy-duty	SNMM190612-AG	2.00-13.00	0.50-1.00				○	●	●													
	SNMM190616-AG	2.50-13.00	0.50-1.10				○	●	●													
	SNMM190624-AG	3.00-13.00	0.60-1.60				○	●	●													
	SNMM250724-AG	3.00-17.00	0.60-1.60				○	●	●													
	SNMM250732-AG	3.50-17.00	0.70-2.00				○	●	●													
	SNMM250924-AG	3.00-17.00	0.60-1.60				○	●	●													
	SNMM250932-AG	3.50-17.00	0.70-2.00				○	●	●													

Note: ●Recommended grade ready to stock

## Negative Inserts

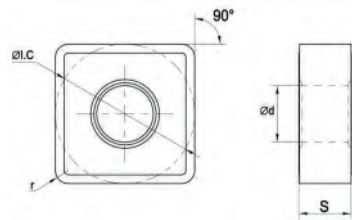

Length	Size(mm)			
	IC	S	d	r
12	12.7	4.76	5.16	0.4-1.2

90° SN□□ With Hole

Shape	Type	ap (mm)	f (mm/rev)	Grade											
				CVD						PVD					
				VK3020	VK3040	VK3115	VK4415	VK4425	VK4435	VK1025	VK1525	VK1825	VK1824	VK1828	VR1610
 M Finishing	SNMG120404-BF	0.20-1.50	0.05-0.15							○	●	○	●		
	SNMG120408-BF	0.40-1.50	0.07-0.20							○	●	○	●		
	SNMG120412-BF	0.50-2.00	0.10-0.25							○	●	○	●		

Note: ●Recommended grade ready to stock

## Negative Inserts

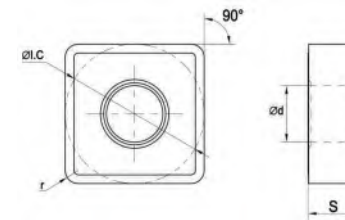

Length	Size(mm)			
	IC	S	d	r
12	12.7	4.76	5.16	0.4-1.2
15	15.875	6.35	6.35	0.8-1.2

90° SN□□ With Hole

Shape	Type	ap (mm)	f (mm/rev)	Grade																
				CVD						PVD										
				VK3020	VK3040	VK3115	VK4415	VK4425	VK4435	VK1025	VK1525	VK1825	VK1824	VK1828	VR1610	VR1525				
 M Semi-finishing	SNMG120404-BM	0.50-2.00	0.10-0.18											○	○	○	●			
	SNMG120408-BM	0.80-3.00	0.15-0.25												○	○	○	●		
	SNMG120412-BM	0.80-3.50	0.18-0.30												○	○	○	●		
	SNMG150608-BM	0.80-4.50	0.15-0.35												○	○	○	●		
	SNMG150612-BM	0.80-4.50	0.18-0.40												○	○	○	●		

Note: ●Recommended grade ready to stock

## Negative Inserts

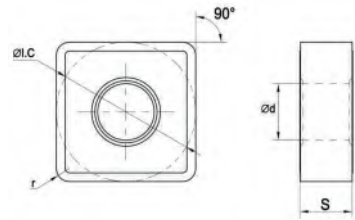

Length	Size(mm)			
	IC	S	d	r
12	12.7	4.76	5.16	0.4-1.2
15	15.875	6.35	6.35	0.8-1.2

90° SN□□ With Hole

Shape	Type	ap (mm)	f (mm/rev)	Grade																			
				CVD						PVD													
				VK3020	VK3040	VK3115	VK4415	VK4425	VK4435	VK1025	VK1525	VK1825	VK1824	VK1828	VR1610	VR1525							
 M Roughing	SNMG120404-BR	0.80-5.00	0.15-0.35																				
	SNMG120408-BR	1.20-5.00	0.20-0.40																				
	SNMG120412-BR	1.50-5.00	0.25-0.50																				
	SNMG150608-BR	1.20-7.00	0.20-0.50																				
	SNMG150612-BR	1.50-7.00	0.25-0.60																				

Note: ● Recommended grade ready to stock

## Negative Inserts

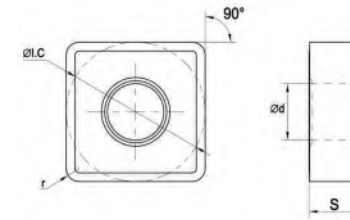

Length	Size(mm)			
	IC	S	d	r
12	12.7	4.76	5.16	0.4-1.6
15	15.875	6.35	6.35	0.8-1.6
19	19.05	6.35	7.94	1.2-1.6

90° SN□□ With Hole

Shape	Type	ap (mm)	f (mm/rev)	Grade																			
				CVD						PVD													
				VK3020	VK3040	VK3115	VK4415	VK4425	VK4435	VK1025	VK1525	VK1825	VK1824	VK1828	VR1610	VR1525							
 K Semi-finishing	SNMG120404-CM	0.60-5.00	0.16-0.25																				
	SNMG120408-CM	0.80-5.00	0.25-0.50																				
	SNMG120412-CM	1.20-5.00	0.30-0.50																				

Note: ● Recommended grade ready to stock

## Negative Inserts

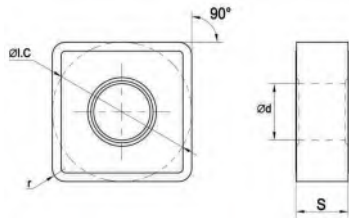

Length	Size(mm)			
	IC	S	d	RE
12	12.7	4.76	5.16	0.4-1.6
15	15.875	6.35	6.35	1.2-1.6
19	19.05	6.35	7.94	1.2-1.6

90° SN□□ With Hole

Shape	Type	ap (mm)	f (mm/rev)	Grade													
				CVD						PVD							
				VK3020	VK3040	VK3115	VK4415	VK4425	VK4435	VK1025	VK1525	VK1825	VK1824	VK1828	VR1610	VR1525	
K Roughing	SNMA120404	0.60-5.00	0.16-0.25			●	○	○									
	SNMA120408	0.80-5.00	0.25-0.50			●	○	○									
	SNMA120412	1.20-5.00	0.30-0.60			●	○	○									
	SNMA120416	1.50-5.00	0.35-0.70			●	○	○									
	SNMA150612	1.20-7.00	0.30-0.65			●	○	○									
	SNMA150616	1.50-7.00	0.35-0.80			●	○	○									
	SNMA190612	1.20-8.00	0.30-0.65			●	○	○									
	SNMA190616	1.50-8.00	0.35-0.80			●	○	○									

Note: ●Recommended grade ready to stock

## Negative Inserts

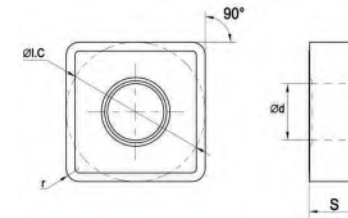

Length	Size(mm)			
	IC	S	d	r
12	12.7	4.76	5.16	0.4-1.6
15	15.875	6.35	6.35	0.8-1.6

90° SN□□ With Hole

Shape	Type	ap (mm)	f (mm/rev)	Grade												
				CVD				PVD								
				VK3115	VK4415	VK4425	VK4435	VK1025	VK1525	VK1825	VK1824	VK1828	VK1605	VR1510	VR1610	VR1525
S Medium- Rough Machining	SNMG120404-DM	0.80-5.00	0.15-0.35							○		○		●	○	●
	SNMG120408-DM	1.20-5.00	0.20-0.40							○		○		●	○	●
	SNMG120412-DM	1.50-5.00	0.25-0.50							○		○		●	○	●
	SNMG120416-DM	2.00-5.00	0.30-0.55							○		○		●	○	●
	SNMG150608-DM	1.20-7.00	0.20-0.50							○		○		●	○	●
	SNMG150612-DM	1.50-7.00	0.25-0.60							○		○		●	○	●
	SNMG150616-DM	2.00-7.00	0.30-0.65							○		○		●	○	●

Note: ●Recommended grade ready to stock

## Negative Inserts

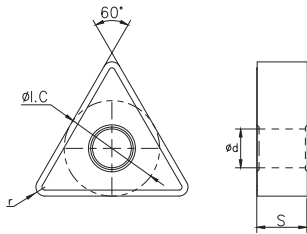

Length	Size(mm)			
	IC	S	d	r
16	9.525	4.76	3.81	0.4-1.2

60° TN□□ With Hole

Shape	Type	ap (mm)	f (mm/rev)	Grade																			
				CVD						PVD													
				VK3020	VK3040	VK3115	VK4415	VK4425	VK4435	VK1025	VK1525	VK1825	VK1824	VK1828	VR1610	VR1525							
P Finishing	TNMG160404-AF	0.10-1.50	0.04-0.20				●	○															
	TNMG160408-AF	0.20-2.00	0.08-0.25				●	○															
	TNMG160412-AF	0.50-2.50	0.10-0.25				●	○															

Note: ●Recommended grade ready to stock

## Negative Inserts

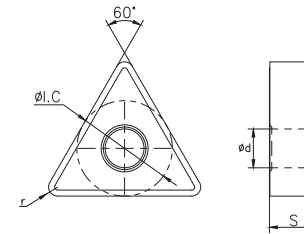

Length	Size(mm)			
	IC	S	d	r
16	9.525	4.76	3.81	0.4-1.2
22	12.7	4.76	5.16	0.8-1.6

60° TN□□ With Hole

Shape	Type	ap (mm)	f (mm/rev)	Grade																			
				CVD						PVD													
				VK3020	VK3040	VK3115	VK4415	VK4425	VK4435	VK1025	VK1525	VK1825	VK1824	VK1828	VR1610	VR1525							
P Semi-finishing	TNMG160404-AS	0.50-4.00	0.16-0.25				○	●	○														
	TNMG160408-AS	0.60-4.00	0.18-0.35				○	●	○														
	TNMG160412-AS	1.00-4.00	0.20-0.40				○	●	○														
	TNMG220408-AS	0.80-5.00	0.18-0.35				○	●	○														
	TNMG220412-AS	1.00-5.00	0.20-0.40				○	●	○														
	TNMG220416-AS	1.20-5.00	0.25-0.45				○	●	○														

Note: ●Recommended grade ready to stock

## Negative Inserts

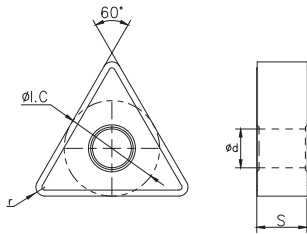

Length	Size(mm)			
	IC	S	d	r
16	9.525	4.76	3.81	0.4-1.2
22	12.7	4.76	5.16	0.8-1.6

60° TN□□ With Hole

Shape	Type	ap (mm)	f (mm/rev)	Grade																			
				CVD						PVD													
				VK3020	VK3040	VK3115	VK4415	VK4425	VK4435	VK1025	VK1525	VK1825	VK1824	VK1828	VR1610	VR1525							
 P Medium machining	TNMG160404-AM	0.40-5.00	0.10-0.30				○	●	○														
	TNMG160408-AM	0.50-5.00	0.15-0.50				○	●	○														
	TNMG160412-AM	0.80-5.00	0.18-0.60				○	●	○														
	TNMG220408-AM	0.50-6.60	0.15-0.50				○	●	○														
	TNMG220412-AM	0.80-6.60	0.18-0.60				○	●	○														
	TNMG220416-AM	1.00-6.00	0.23-0.65				○	●	○														

Note: ●Recommended grade ready to stock

## Negative Inserts

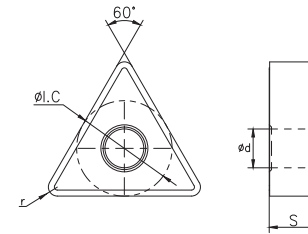

Length	Size(mm)			
	IC	S	d	r
16	9.525	4.76	3.81	0.8-1.2
22	12.7	4.76	5.16	0.8-1.6

60° TN□□ With Hole

Shape	Type	ap (mm)	f (mm/rev)	Grade																			
				CVD						PVD													
				VK3020	VK3040	VK3115	VK4415	VK4425	VK4435	VK1025	VK1525	VK1825	VK1824	VK1828	VR1610	VR1525							
 P Roughing	TNMG160408-AG	0.80-5.00	0.20-0.40				○	●	●														
	TNMG220408-AG	0.80-7.00	0.20-0.45				○	●	●														
	TNMG220412-AG	1.00-7.00	0.25-0.60				○	●	●														

Note: ●Recommended grade ready to stock

## Negative Inserts

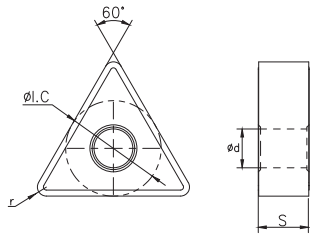

Length	Size(mm)			
	IC	S	d	r
16	9.525	4.76	3.81	0.4-1.2

60° TN□□ With Hole

Shape	Type	ap (mm)	f (mm/rev)	Grade											
				CVD						PVD					
				VK3020	VK3040	VK3115	VK4415	VK4425	VK4435	VK1025	VK1525	VK1825	VK1824	VK1828	VR1610
 M Finishing	TNMG160404-BF	0.20-1.00	0.05-0.15							○	●	○	●		
	TNMG160408-BF	0.40-1.50	0.07-0.20							○	●	○	●		
	TNMG160412-BF	0.50-2.00	0.10-0.25							○	●	○	●		

Note: ●Recommended grade ready to stock

## Negative Inserts

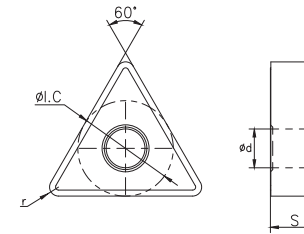

Length	Size(mm)			
	IC	S	d	r
16	9.525	4.76	3.81	0.4-1.2
22	12.7	4.76	5.16	0.8-1.6

60° TN□□ With Hole

Shape	Type	ap (mm)	f (mm/rev)	Grade																
				CVD						PVD										
				VK3020	VK3040	VK3115	VK4415	VK4425	VK4435	VK1025	VK1525	VK1825	VK1824	VK1828	VR1610	VR1525				
 M Semi-finishing	TNMG160404-BM	0.50-2.00	0.10-0.18											○	○	○	●			
	TNMG160408-BM	0.80-3.00	0.15-0.25												○	○	○	●		
	TNMG160412-BM	0.80-3.50	0.18-0.30												○	○	○	●		
	TNMG220408-BM	0.80-3.50	0.15-0.25												○	○	○	●		
	TNMG220412-BM	0.80-4.00	0.18-0.30												○	○	○	●		

Note: ●Recommended grade ready to stock

## Negative Inserts

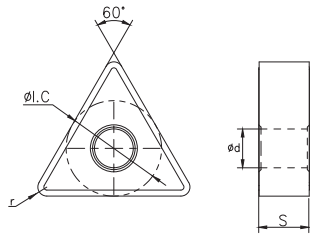

Length	Size(mm)			
	IC	S	d	r
16	9.525	4.76	3.81	0.4-1.2
22	12.7	4.76	5.16	0.8-1.2

60° TN□□ With Hole

Shape	Type	ap (mm)	f (mm/rev)	Grade											
				CVD						PVD					
				VK3020	VK3040	VK3115	VK4415	VK4425	VK4435	VK1025	VK1525	VK1825	VK1824	VK1828	VR1610
 M Semi-finishing	TNMG160404-BR	0.80-4.00	0.15-0.35						○	○		○	●		
	TNMG160408-BR	1.20-4.00	0.20-0.40						○	○		○	●		
	TNMG160412-BR	1.50-4.00	0.25-0.50						○	○		○	●		
	TNMG220408-BR	0.20-5.00	0.20-0.40						○	○		○	●		
	TNMG220412-BR	1.50-5.00	0.25-0.55						○	○		○	●		

Note: ●Recommended grade ready to stock

## Negative Inserts

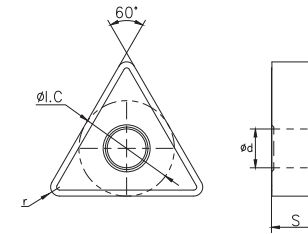

Length	Size(mm)			
	IC	S	d	r
16	9.525	4.76	3.81	0.4-1.2
22	12.7	4.76	5.16	0.8-1.6

60° TN□□ With Hole

Shape	Type	ap (mm)	f (mm/rev)	Grade											
				CVD						PVD					
				VK3020	VK3040	VK3115	VK4415	VK4425	VK4435	VK1025	VK1525	VK1825	VK1824	VK1828	VR1610
 K Semi-finishing	TNMG160404-CM	0.60-4.00	0.16-0.25			●	○	○							
	TNMG160408-CM	0.80-5.00	0.25-0.45			●	○	○							
	TNMG160412-CM	1.20-5.00	0.30-0.45			●	○	○							
	TNMG220412-CM	1.40-6.00	0.30-0.45			●	○	○							

Note: ●Recommended grade ready to stock

## Negative Inserts

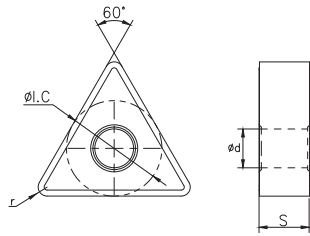

Length	Size(mm)			
	IC	S	d	RE
16	9.525	4.76	3.81	0.4-1.2
22	12.7	4.76	5.16	0.8-1.6

60° TN□□ With Hole

Shape	Type	ap (mm)	f (mm/rev)	Grade														
				CVD						PVD								
				VK3020	VK3040	VK3115	VK4415	VK4425	VK4435	VK1025	VK1525	VK1825	VK1824	VK1828	VR1610	VR1525		
 K Roughing	TNMA160404	0.60-5.00	0.16-0.25			●	○	○										
	TNMA160408	0.80-5.00	0.25-0.45			●	○	○										
	TNMA160412	1.20-5.00	0.30-0.50			●	○	○										
	TNMA160416	1.50-5.00	0.35-0.60			●	○	○										
	TNMA220408	1.00-6.00	0.25-0.45			●	○	○										
	TNMA220412	1.40-6.00	0.35-0.55			●	○	○										
	TNMA220416	1.60-6.00	0.35-0.60			●	○	○										

Note: ●Recommended grade ready to stock

## Negative Inserts

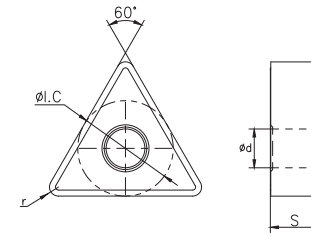

Length	Size(mm)			
	IC	S	d	r
16	9.525	4.76	3.81	0.4-0.8

60° TN□□ With Hole

Shape	Type	ap (mm)	f (mm/rev)	Grade															
				CVD						PVD									
				VK3020	VK3040	VK3115	VK4415	VK4425	VK4435	VK1025	VK1525	VK1825	VK1824	VK1828	VR1610	VR1525			
 K Semi-finishing	TNMG160404-DM	0.80-4.00	0.15-0.35											○			●	○	●
	TNMG160408-DM	1.20-4.00	0.20-0.40											○			●	○	●

Note: ●Recommended grade ready to stock

## Negative Inserts

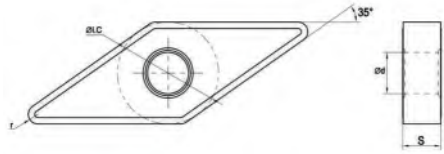

Length	Size(mm)			
	IC	S	d	r
16	9.525	4.76	3.81	0.4-1.2

35° VN□□ With Hole

Shape	Type	ap (mm)	f (mm/rev)	Grade																		
				CVD						PVD												
				VK3020	VK3040	VK3115	VK4415	VK4425	VK4435	VK1025	VK1525	VK1825	VK1824	VK1828	VR1610	VR1525						
P Finishing	VNMG160404-AF	0.10-1.50	0.04-0.00				●	○														
	VNMG160408-AF	0.20-2.00	0.08-0.25				●	○														
	VNMG160412-AF	0.30-2.50	0.12-0.28				●	○														

Note: ●Recommended grade ready to stock

## Negative Inserts

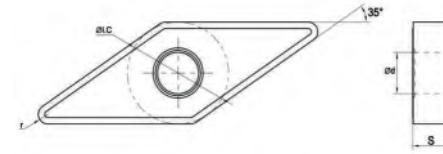

Length	Size(mm)			
	IC	S	d	r
11	6.35	4.76	2.26	0.4-0.8
16	9.525	4.76	3.81	0.4-0.8

35° VN□□ With Hole

Shape	Type	ap (mm)	f (mm/rev)	Grade																		
				CVD						PVD												
				VK3020	VK3040	VK3115	VK4415	VK4425	VK4435	VK1025	VK1525	VK1825	VK1824	VK1828	VR1610	VR1525						
P Semi-finishing	VNMG110404-AS	0.40-1.50	0.10-0.18				○	●	○													
	VNMG110408-AS	0.50-2.50	0.18-0.35				○	●	○													
	VNMG160404-AS	0.50-2.00	0.10-0.18				○	●	○													
	VNMG160408-AS	0.60-4.00	0.18-0.35				○	●	○													

Note: ●Recommended grade ready to stock

## Negative Inserts

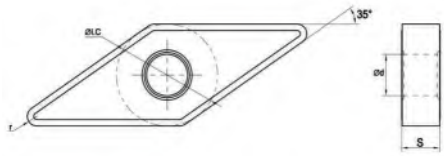

Length	Size(mm)			
	IC	S	d	r
11	6.35	4.76	2.26	0.4-0.8
16	9.525	4.76	3.81	0.4-0.8

35° VN□□ With Hole

Shape	Type	ap (mm)	f (mm/rev)	Grade														
				CVD						PVD								
				VK3020	VK3040	VK3115	VK4415	VK4425	VK4435	VK1025	VK1525	VK1825	VK1824	VK1828	VR1610	VR1525		
	VNMG160408-AM	0.50-4.00	0.15-0.5				○	●	○									
	VNMG160412-AM	0.80-4.00	0.18-0.6				○	●	○									
P Medium machining																		

Note: ●Recommended grade ready to stock

## Negative Inserts

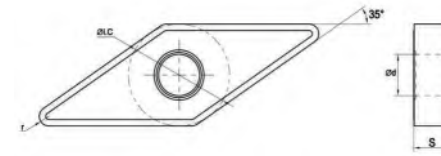

Length	Size(mm)			
	IC	S	d	r
16	9.525	4.76	3.81	0.4-1.2

35° VN□□ With Hole

Shape	Type	ap (mm)	f (mm/rev)	Grade														
				CVD						PVD								
				VK3020	VK3040	VK3115	VK4415	VK4425	VK4435	VK1025	VK1525	VK1825	VK1824	VK1828	VR1610	VR1525		
	VNMG160404-BF	0.10-1.00	0.05-0.15												○	●	○	●
	VNMG160408-BF	0.40-1.50	0.07-0.20												○	●	○	●
	VNMG160412-BF	0.50-2.00	0.10-0.25												○	●	○	●
M Finishing																		

Note: ●Recommended grade ready to stock

## Negative Inserts

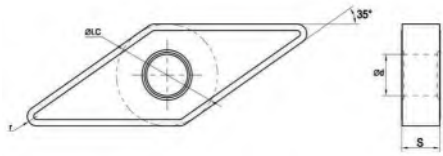

Length	Size(mm)			
	IC	S	d	r
16	9.525	4.76	3.81	0.4-0.8

35° VN□□ With Hole

Shape	Type	ap (mm)	f (mm/rev)	Grade											
				CVD						PVD					
				VK3020	VK3040	VK3115	VK4415	VK4425	VK4435	VK1025	VK1525	VK1825	VK1824	VK1828	VR1610
	VNMG160404-BM	0.50-2.00	0.10-0.18							○	○	○	●		
	VNMG160408-BM	0.80-3.00	0.15-0.25							○	○	○	●		
M Finishing															

Note: ●Recommended grade ready to stock

## Negative Inserts

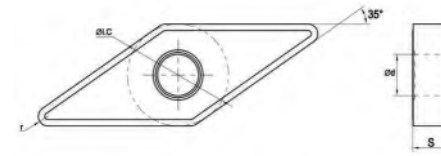

Length	Size(mm)			
	IC	S	d	r
16	9.525	4.76	3.81	0.4-1.2

35° VN□□ With Hole

Shape	Type	ap (mm)	f (mm/rev)	Grade											
				CVD						PVD					
				VK3020	VK3040	VK3115	VK4415	VK4425	VK4435	VK1025	VK1525	VK1825	VK1824	VK1828	VR1610
	VNMG160404-CM	0.60-4.00	0.16-0.25			●	○	○							
	VNMG160408-CM	0.80-4.00	0.18-0.35			●	○	○							
	VNMG160412-CM	1.00-4.00	0.20-0.35			●	○	○							
K Semi-finishing															

Note: ●Recommended grade ready to stock

## Negative Inserts

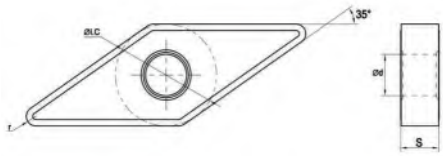

Length	Size(mm)			
	IC	S	d	r
16	9.525	4.76	3.81	0.4-0.8

35° VN□□ With Hole

Shape	Type	ap (mm)	f (mm/rev)	Grade													
				CVD						PVD							
				VK3020	VK3040	VK3115	VK4415	VK4425	VK4435	VK1025	VK1525	VK1825	VK1824	VK1828	VR1610	VR1525	
	VNMG160404-DM	0.15-2.00	0.05-0.20							○	○	○	●				
	VNMG160408-DM	0.20-2.50	0.07-0.23							○	○	○	●				
M Finishing																	

Note: ●Recommended grade ready to stock

## Negative Inserts

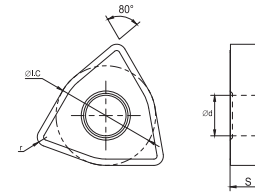

Length	Size(mm)			
	IC	S	d	r
8	12.7	4.76	5.16	0.4-1.2

80° WN□□ With Hole

Shape	Type	ap (mm)	f (mm/rev)	Grade													
				CVD						PVD							
				VK3020	VK3040	VK3115	VK4415	VK4425	VK4435	VK1025	VK1525	VK1825	VK1824	VK1828	VR1610	VR1525	
	WNMG080404-AF	0.10-1.50	0.05-0.20														
	WNMG080408-AF	0.20-2.00	0.08-0.25														
	WNMG080412-AF	0.50-2.50	0.10-0.25														
P Finishing																	

Note: ●Recommended grade ready to stock



## Negative Inserts

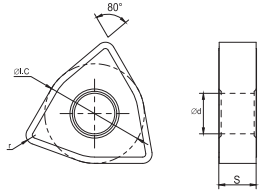

Length	Size(mm)			
	IC	S	d	r
6	9.525	4.76	3.81	0.8-1.2
8	12.7	4.76	5.16	0.8-1.2

80° WN□□ With Hole

Shape	Type	ap (mm)	f (mm/rev)	Grade																	
				CVD							PVD										
				VK3020	VK3040	VK3115	VK4415	VK4425	VK4435	VK1025	VK1525	VK1825	VK1824	VK1828	VR1610	VR1525					
P Roughing	WNMG060408-AG	0.80-4.00	0.20-0.40				○	●	●												
	WNMG060412-AG	1.00-4.00	0.25-0.50				○	●	●												
	WNMG080408-AG	0.80-6.00	0.20-0.40				○	●	●												
	WNMG080412-AG	1.00-6.00	0.25-0.60				○	●	●												

Note: ●Recommended grade ready to stock

## Negative Inserts

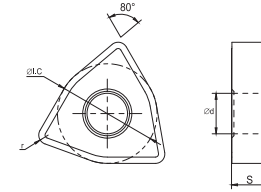

Length	Size(mm)			
	IC	S	d	r
6	9.525	4.76	3.81	0.4-0.8
8	12.7	4.76	5.16	0.4-1.6

80° WN□□ With Hole

Shape	Type	ap (mm)	f (mm/rev)	Grade																	
				CVD							PVD										
				VK3020	VK3040	VK3115	VK4415	VK4425	VK4435	VK1025	VK1525	VK1825	VK1824	VK1828	VR1610	VR1525					
M Finishing	WNMG060404-BF	0.20-1.00	0.05-0.15																		
	WNMG060408-BF	0.40-1.50	0.07-0.20																		
	WNMG080404-BF	0.20-1.50	0.05-0.15																		
	WNMG080408-BF	0.40-1.50	0.07-0.20																		
	WNMG080412-BF	0.50-2.00	0.10-0.25																		
	WNMG080416-BF	0.60-2.00	0.15-0.30																		

Note: ●Recommended grade ready to stock

## Negative Inserts

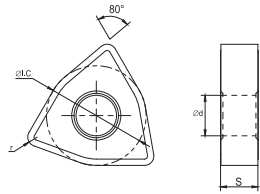

Length	Size(mm)			
	IC	S	d	r
6	9.525	4.76	3.81	0.4-0.8
8	12.7	4.76	5.16	0.4-1.6

80° WN□□ With Hole

Shape	Type	ap (mm)	f (mm/rev)	Grade													
				CVD						PVD							
				VK3020	VK3040	VK3115	VK4415	VK4425	VK4435	VK1025	VK1525	VK1825	VK1824	VK1828	VR1610	VR1525	
M Semi-finishing	WNMG060404-BM	0.50-2.00	0.10-0.18							○	○	○	●				
	WNMG060408-BM	0.80-2.50	0.15-0.25							○	○	○	●				
	WNMG080404-BM	0.50-3.00	0.10-0.20							○	○	○	●				
	WNMG080408-BM	0.80-3.00	0.15-0.32							○	○	○	●				
	WNMG080412-BM	0.80-3.50	0.15-0.35							○	○	○	●				
	WNMG080416-BM	1.00-4.00	0.15-0.40							○	○	○	●				

Note: ●Recommended grade ready to stock

## Negative Inserts

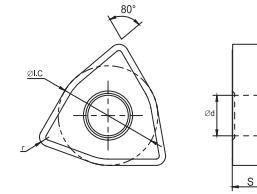

Length	Size(mm)			
	IC	S	d	r
6	9.525	4.76	3.81	0.4-0.8
8	12.7	4.76	5.16	0.4-1.6

80° WN□□ With Hole

Shape	Type	ap (mm)	f (mm/rev)	Grade																
				CVD						PVD										
				VK3020	VK3040	VK3115	VK4415	VK4425	VK4435	VK1025	VK1525	VK1825	VK1824	VK1828	VR1610	VR1525				
M Roughing	WNMG060404-BR	0.80-3.50	0.15-0.35											○	○		○	●		
	WNMG060408-BR	1.20-3.50	0.20-0.40											○	○		○	●		
	WNMG080404-BR	0.80-4.50	0.15-0.35											○	○		○	●		
	WNMG080408-BR	1.20-4.50	0.20-0.40											○	○		○	●		
	WNMG080412-BR	1.50-4.50	0.25-0.50											○	○		○	●		
	WNMG080416-BR	2.00-4.50	0.30-0.55											○	○		○	●		

Note: ●Recommended grade ready to stock

## Negative Inserts

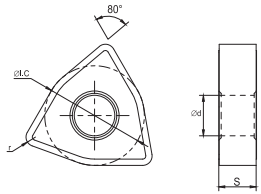

Length	Size(mm)			
	IC	S	d	r
8	12.7	4.76	5.16	0.4-1.6

80° WN□□ With Hole

Shape	Type	ap (mm)	f (mm/rev)	Grade															
				CVD							PVD								
				VK3020	VK3040	VK3115	VK4415	VK4425	VK4435	VK1025	VK1525	VK1825	VK1824	VK1828	VR1610	VR1525			
 K Semi-finishing	WNMG080404-CM	0.60-5.00	0.16-0.25		●	○	○												
	WNMG080408-CM	1.20-5.00	0.20-0.45		●	○	○												
	WNMG080412-CM	1.50-5.00	0.22-0.50		●	○	○												

Note: ●Recommended grade ready to stock

## Negative Inserts

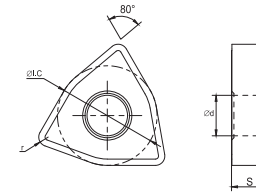

Length	Size(mm)			
	IC	S	d	RE
8	12.7	4.76	5.16	0.4-1.6

80° WN□□ With Hole

Shape	Type	ap (mm)	f (mm/rev)	Grade															
				CVD							PVD								
				VK3020	VK3040	VK3115	VK4415	VK4425	VK4435	VK1025	VK1525	VK1825	VK1824	VK1828	VR1610	VR1525			
 K Roughing	WNMA080404	0.60-5.00	0.16-0.25		●	○	○												
	WNMA080408	1.20-5.00	0.20-0.45		●	○	○												
	WNMA080412	1.50-5.00	0.22-0.50		●	○	○												
	WNMA080416	1.50-5.00	0.25-0.60		●	○	○												

Note: ●Recommended grade ready to stock



## Negative Inserts

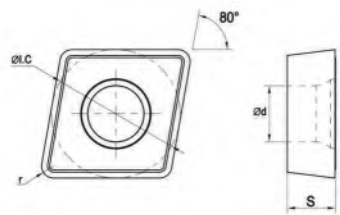

Length	Size(mm)			
	IC	S	d	r
6	3.65	2.38	2.8	0.4-0.8
9	9.525	3.97	4.4	0.4-0.8

80° CC□□ With Hole

Shape	Type	ap (mm)	f (mm/rev)	Grade											
				CVD						PVD					
				VK3020	VK3040	VK3115	VK4415	VK4425	VK4435	VK1025	VK1525	VK1825	VK1824	VK1828	VR1610
 M Finishing	CCMT060202-GF	0.10-1.00	0.04-0.12							○	●	○	●		
	CCMT060204-GF	0.10-1.50	0.05-0.16							○	●	○	●		
	CCMT060208-GF	0.10-1.50	0.08-0.20							○	●	○	●		
	CCMT09T302-GF	0.10-1.00	0.04-0.12							○	●	○	●		
	CCMT09T304-GF	0.10-1.50	0.05-0.16							○	●	○	●		
	CCMT09T308-GF	0.10-1.50	0.08-0.20							○	●	○	●		

Note: ●Recommended grade ready to stock

## Negative Inserts

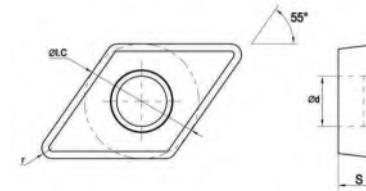

Length	Size(mm)			
	IC	S	d	r
7	6.35	2.38	2.8	0.4-0.8
11	9.525	3.97	4.4	0.4-1.2

55° DC□□ With Hole

Shape	Type	ap (mm)	f (mm/rev)	Grade												
				CVD				PVD								
				VK3115	VK4415	VK4425	VK4435	VK1025	VK1525	VK1825	VK1824	VK1828	VK1605	VR1510	VR1610	VR1525
 General Semi-finishing	DCMT070204-GM	0.40-2.50	0.10-0.20	●	●			○		●		○				○
	DCMT070208-GM	0.60-2.50	0.15-0.25	●	●			○		●		○				○
	DCMT11T304-GM	0.40-3.50	0.10-0.25	●	●			○		●		○				○
	DCMT11T308-GM	0.60-3.50	0.15-0.32	●	●			○		●		○				○
	DCMT11T312-GM	0.60-3.50	0.18-0.35	●	●			○		●		○				○

Note: ●Recommended grade ready to stock

## Negative Inserts

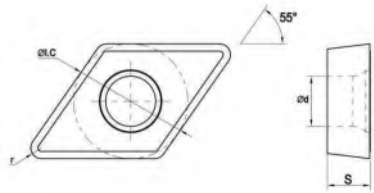

Length	Size(mm)			
	IC	S	d	r
7	6.35	2.38	2.8	0.4-0.8
11	9.525	3.97	4.4	0.4-1.2

55° DC□□ With Hole

Shape	Type	ap (mm)	f (mm/rev)	Grade											
				CVD						PVD					
				VK3020	VK3040	VK3115	VK4415	VK4425	VK4435	VK1025	VK1525	VK1825	VK1824	VK1828	VR1610
M Finishing	DCMT070204-GF	0.10-1.50	0.05-0.16							○	●	○	●		
	DCMT070208-GF	0.10-1.50	0.08-0.20							○	●	○	●		
	DCMT11T304-GF	0.10-1.50	0.05-0.16							○	●	○	●		
	DCMT11T308-GF	0.10-1.50	0.08-0.20							○	●	○	●		
	DCMT11T312-GF	0.10-1.50	0.10-0.25							○	●	○	●		

Note: ●Recommended grade ready to stock

## Negative Inserts

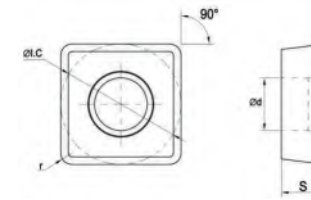

Length	Size(mm)			
	IC	S	d	r
9	9.525	3.97	4.4	0.4-0.8
12	12.7	4.76	5.56	0.4-1.2

90° SC□□ With Hole

Shape	Type	ap (mm)	f (mm/rev)	Grade												
				CVD				PVD								
				VK3115	VK4415	VK4425	VK4435	VK1025	VK1525	VK1825	VK1824	VK1828	VK1605	VR1510	VR1610	VR1525
General Semi-finishing	SCMT09T304-GM	0.40-3.00	0.08-0.25	●	●			○		●		○				○
	SCMT09T308-GM	0.50-3.00	0.12-0.32	●	●			○		●		○				○
	SCMT120404-GM	0.50-4.00	0.12-0.32	●	●			○		●		○				○
	SCMT120408-GM	0.60-4.00	0.15-0.35	●	●			○		●		○				○
	SCMT120412-GM	0.80-4.00	0.20-0.40	●	●			○		●		○				○

Note: ●Recommended grade ready to stock

## Negative Inserts

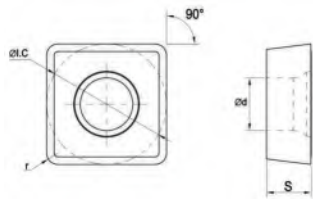

Length	Size(mm)			
	IC	S	d	r
9	9.525	3.97	4.4	0.4-0.8

90° SC□□ With Hole

Shape	Type	ap (mm)	f (mm/rev)	Grade												
				CVD						PVD						
				VK3020	VK3040	VK3115	VK4415	VK4425	VK4435	VK1025	VK1525	VK1825	VK1824	VK1828	VR1610	VR1525
 M Finishing	SCMT09T304-GF	0.10-1.50	0.05-0.15							○	●	○	●			
	SCMT09T308-GF	0.10-1.80	0.05-0.18							○	●	○	●			

Note: ●Recommended grade ready to stock

## Negative Inserts

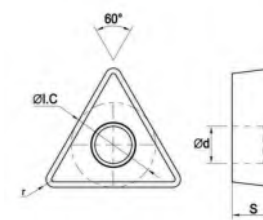

Length	Size(mm)			
	IC	S	d	r
9	5.56	2.38	2.2	0.4-0.8
11	6.35	2.38	2.8	0.4-1.2
16	9.525	3.97	4.4	0.4-1.2

60° TC□□ With Hole

Shape	Type	ap (mm)	f (mm/rev)	Grade											
				CVD				PVD							
				VK3115	VK4415	VK4425	VK4435	VK1025	VK1525	VK1825	VK1824	VK1828	VK1605	VR1510	VR1610
 General Semi-finishing	TCMT090204-GM	0.40-2.50	0.10-0.20	●	●		○		●	○					○
	TCMT090208-GM	0.60-2.50	0.10-0.25	●	●		○		●	○					○
	TCMT110204-GM	0.40-2.50	0.10-0.20	●	●		○		●	○					○
	TCMT110208-GM	0.60-2.50	0.10-0.25	●	●		○		●	○					○
	TCMT110212-GM	0.60-2.50	0.15-0.32	●	●		○		●	○					○
	TCMT16T304-GM	0.40-3.50	0.10-0.25	●	●		○		●	○					○
	TCMT16T308-GM	0.60-3.50	0.15-0.32	●	●		○		●	○					○
	TCMT16T312-GM	0.60-3.50	0.20-0.40	●	●		○		●	○					○

Note: ●Recommended grade ready to stock

## Negative Inserts

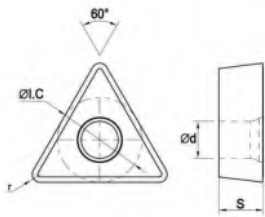

Length	Size(mm)			
	IC	S	d	r
9	5.56	2.38	2.2	0.4-0.8
11	6.35	2.38	2.8	0.4-1.2
16	9.525	3.97	4.4	0.4-1.2

60° TC□□ With Hole

Shape	Type	ap (mm)	f (mm/rev)	Grade												
				CVD						PVD						
				VK3020	VK3040	VK3115	VK4415	VK4425	VK4435	VK1025	VK1525	VK1825	VK1824	VK1828	VR1610	VR1525
M Finishing	TCMT090204-GF	0.10-1.50	0.05-0.16								○	●	○	●		
	TCMT090208-GF	0.10-1.50	0.08-0.20								○	●	○	●		
	TCMT110204-GF	0.10-1.50	0.05-0.16								○	●	○	●		
	TCMT110208-GF	0.10-1.50	0.08-0.20								○	●	○	●		
	TCMT110212-GF	0.10-1.50	0.10-0.25								○	●	○	●		
	TCMT16T304-GF	0.10-1.50	0.05-0.16								○	●	○	●		
	TCMT16T308-GF	0.10-1.50	0.08-0.20								○	●	○	●		
	TCMT16T312-GF	0.10-1.50	0.10-0.25							○	●	○	●			

Note: ● Recommended grade ready to stock

## Precision Parts Machining

New Series of Products

### The Intro of PVD Grades

**VK1805** ISO:P05-P15 M05-M15 S05-S15

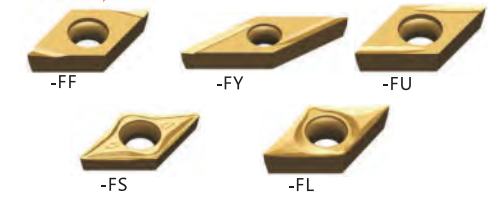

- Utilizing medium-cobalt, fine-grained carbide matrix that offers excellent wear resistance and toughness.
- Combined with PVD nano high-performance composite coating and low surface friction series, effectively inhibits the formation of chip tumors, delivering outstanding overall performance.
  - General turning grade for precision parts.
  - Recommended for turning P and M type materials.
  - Suitable for medium to high cutting speed machining.

**VK1820** ISO:P10-P30 M10-M30



- Utilizing medium-cobalt, fine-grained carbide matrix that offers excellent wear resistance and toughness.
- Combined with PVD nano high-performance composite coating and low surface friction series, effectively inhibits the formation of chip tumors, delivering outstanding overall performance.
  - General turning grade for precision parts.
  - Recommended for turning P and M type materials.
  - Suitable for medium to high cutting speed machining.

### The Application of CVD Grades

Workpiece	P					M					S							
	Wearness ← Toughness					Wearness ← Toughness					Wearness ← Toughness							
ISO	01	10	20	30	40	50	01	10	20	30	40	50	01	10	20	30	40	50
PVD Grades	VK1805					VK1820					VK1805							

### Case

Info.	Import K Company	WecoTool
Lathe	Tsugami 205	
Workpiece material	Austenitic stainless steel 304	
Hardness	180-210	
Workpiece	Bearing	
Processing type	External processing	
Cutter	SUNL1212-11	
Insert	DCGT11T302-S8 P#30	DCGT11T302-PS VK1820
Cutting Parameter		
Vc (m/min)	38-50	40-55
f (mm/rev)	0.1	0.1
ap (mm)	0.3	0.3
Cooling Type	External cooling emulsion	
Test Result		
pcs/edge	1200	1200
Processing Time (min)	abrasive wear	abrasive wear
VB (mm)	0.31	0.12

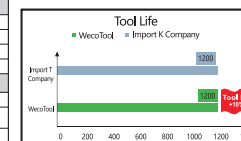

Conclusion: Maintain the same lifespan and increase efficiency by 10%.

Info.	Import N Company	WecoTool
Lathe	Citizen L12	
Workpiece material	SUS202	
Hardness	200-240	
Workpiece	Shaft head	
Processing type	External processing	
Cutter	SUNL1212-11	
Insert	DCGT11T302-C8 P#25	DCGT11T302-FL VK1805
Cutting Parameter		
Vc (m/min)	60	80
f (mm/rev)	0.12	0.12
ap (mm)	0.3	0.3
Cooling Type	External cooling emulsion	
Test Result		
pcs/edge	800	1000
Processing Time (min)	abrasive wear	abrasive wear
VB (mm)	0.13	0.13

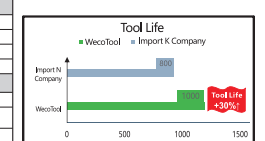

Conclusion: 30% enhancement in both the lifespan and operational efficiency.

## Processing Sword for CNC Precision Automatic Lathe-- High Precision and High-quality Guarantee

### Negative Inserts

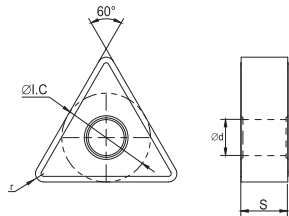

Length	Size(mm)			
	IC	S	d	r
16	9.525	4.76	3.81	0.1-0.4

60° TN□□ With Hole

Shape	Type	ap (mm)	f (mm/rev)	Grade												
				CVD						PVD						
				VK3020	VK3040	VK3115	VK4415	VK4425	VK4435	VK1605	VK1820	VK1625	VK1830	VK1828	VR1610	VR1525
	TNGG160401-FS	0.4-1.5	0.02-0.06						○	●	●	○				
	TNGG160402-FS	0.6-2.0	0.04-0.08						○	●	●	○				
	TNGG160404-FS	0.8-2.5	0.06-0.10						○	●	●	○				
Small Parts Machining																

Note: ●Recommended grade ready to stock

### Negative Inserts

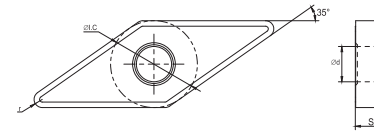

Length	Size(mm)			
	IC	S	d	r
16	9.525	4.76	3.81	0.2-0.8

35° VN□□ With Hole

Shape	Type	ap (mm)	f (mm/rev)	Grade												
				CVD						PVD						
				VK3020	VK3040	VK3115	VK4415	VK4425	VK4435	VK1605	VK1820	VK1625	VK1830	VK1828	VR1610	VR1525
	VNGG160402-FS	0.4-2.0	0.02-0.06									○	●	●	○	
	VNGG160404-FS	0.8-2.5	0.04-0.08									○	●	●	○	
	VNGG160408-FS	1.0-3.0	0.06-0.12									○	●	●	○	
Small Parts Machining																

Note: ●Recommended grade ready to stock

## Positive Inserts



Length	Size(mm)			
	IC	S	d	r
9	6.35	3.97	4.4	0.1-0.8

55° DC□□ With Hole

Shape	Type	ap (mm)	f (mm/rev)	Grade													
				CVD						PVD							
				VK3020	VK3040	VK3115	VK4415	VK4425	VK4435	VK1605	VK1820	VK1625	VK1830	VK1828	VR1610	VR1525	
	DCGT11T301-FS	0.10-1.50	0.02-0.06							○	●	●	○				
	DCGT11T302-FS	0.20-2.00	0.05-0.12							○	●	●	○				
	DCGT11T304-FS	0.20-2.50	0.08-0.25							○	●	●	○				
	DCGT11T308-FS	0.30-3.00	0.10-0.30							○	●	●	○				
Small Parts Machining																	

Note: ●Recommended grade ready to stock

## Positive Inserts

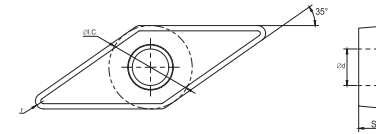

Length	Size(mm)			
	IC	S	d	r
11	6.35	3.18	2.81	0.1-0.4

35° VB□□ With Hole

Shape	Type	ap (mm)	f (mm/rev)	Grade													
				CVD						PVD							
				VK3020	VK3040	VK3115	VK4415	VK4425	VK4435	VK1605	VK1820	VK1625	VK1830	VK1828	VR1610	VR1525	
	VBGT110301-FS	0.1-1.5	0.02-0.06											○	●	●	○
	VBGT110302-FS	0.2-2.0	0.05-0.12											○	●	●	○
	VBGT110304-FS	0.2-2.5	0.08-0.25											○	●	●	○
Small Parts Machining																	

Note: ●Recommended grade ready to stock

## Positive Inserts

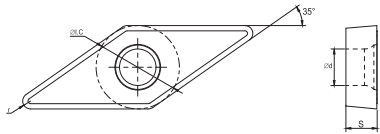

Length	Size(mm)			
	IC	S	d	r
11	6.35	3.18	2.81	0.1-0.4

35° VC□□ With Hole

Shape	Type	ap (mm)	f (mm/rev)	Grade													
				CVD						PVD							
				VK3020	VK3040	VK3115	VK4415	VK4425	VK4435	VK1605	VK1820	VK1625	VK1830	VK1828	VR1610	VR1525	
 Small Parts Machining	VCGT110301-FS	0.1-1.5	0.02-0.06							○	●	●	○				
	VCGT110302-FS	0.2-2.0	0.05-0.12							○	●	●	○				
	VCGT110304-FS	0.2-2.5	0.08-0.25							○	●	●	○				

Note: ●Recommended grade ready to stock

## Positive Inserts

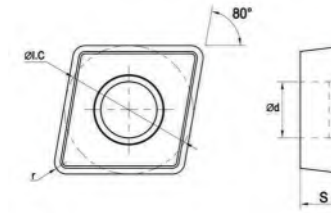

Length	Size(mm)			
	IC	S	d	r
9	9.525	3.97	4.4	0.1
9	9.525	3.97	4.4	0.2
9	9.525	3.97	4.4	0.4

80° CC□□ With Hole

Shape	Type	ap (mm)	f (mm/rev)	Grade													
				CVD						PVD							
				VK3020	VK3040	VK3115	VK4415	VK4425	VK4435	VK1605	VK1820	VK1625	VK1830	VK1828	VR1610	VR1525	
 Small Parts Machining	CCGT09T301R/L-UF	0.1-1.5	0.05-0.15									○	●	●	○		
	CCGT09T302R/L-UF	0.2-2	0.05-0.2							○	●	●	○				
	CCGT09T304R/L-UF	0.4-2.5	0.05-0.25							○	●	●	○				

Note: ●Recommended grade ready to stock

## Positive Inserts

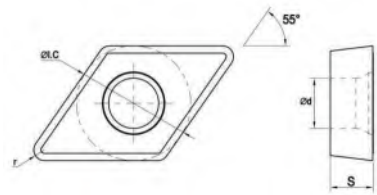

Length	Size(mm)			
	IC	S	d	r
7	6.35	2.38	2.8	0.05-0.2
11	9.525	3.97	4.4	0.1-0.2

55° DC□□ With Hole

Shape	Type	ap (mm)	f (mm/rev)	Grade													
				CVD						PVD							
				VK3020	VK3040	VK3115	VK4415	VK4425	VK4435	VK1605	VK1820	VK1625	VK1830	VK1828	VR1610	VR1525	
 Small Parts Machining	DCGT0702005R/L-UF	0.1-1	0-0.1							○	●	●	○				
	DCGT070201R/L-UF	0.1-1.5	0.05-0.15							○	●	●	○				
	DCGT070202R/L-UF	0.2-2	0.05-0.2							○	●	●	○				
	DCGT11T301R/F-UF	0.1-1.5	0.05-0.15							○	●	●	○				
	DCGT11T302R/F-UF	0.2-2	0.05-0.2							○	●	●	○				

Note: ●Recommended grade ready to stock

## Positive Inserts

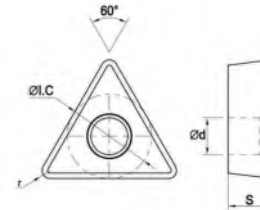

Length	Size(mm)			
	IC	S	d	r
11	6.35	3.18	2.8	0.1-0.2

60° TC□□ With Hole

Shape	Type	ap (mm)	f (mm/rev)	Grade															
				CVD						PVD									
				VK3020	VK3040	VK3115	VK4415	VK4425	VK4435	VK1605	VK1820	VK1625	VK1830	VK1828	VR1610	VR1525			
 Small Parts Machining	TCGT110301R/L-UF	0.1-1.5	0.05-0.15											○	●	●	○		
	TCGT110302R/L-UF	0.2-2	0.05-0.2							○	●	●	○						

Note: ●Recommended grade ready to stock

## Positive Inserts

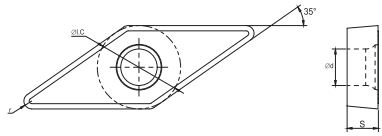

Length	Size(mm)			
	IC	S	d	r
8	4.76	2.38	2.3	0.1-0.2
11	6.35	3.18	2.8	0.1-0.2

35° VC□□ With Hole

Shape	Type	ap (mm)	f (mm/rev)	Grade													
				CVD						PVD							
				VK3020	VK3040	VK3115	VK4415	VK4425	VK4435	VK1605	VK1820	VK1625	VK1830	VK1828	VR1610	VR1525	
 Small Parts Machining	VCGT080201R/L-UF	0.1-1.5	0.05-0.15							○	●	●	○				
	VCGT080202R/L-UF	0.2-2	0.05-0.2							○	●	●	○				
	VCGT110301R/L-UF	0.1-1.5	0.05-0.15							○	●	●	○				
	VCGT110302R/L-UF	0.2-2	0.05-0.2							○	●	●	○				

Note: ●Recommended grade ready to stock

## Negative Inserts

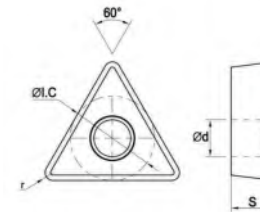

Length	Size(mm)			
	IC	S	d	r
16	9.525	4.76	3.81	0.2-0.8

60° TN□□ With Hole

Shape	Type	ap (mm)	f (mm/rev)	Grade													
				CVD						PVD							
				VK3020	VK3040	VK3115	VK4415	VK4425	VK4435	VK1605	VK1820	VK1625	VK1830	VK1828	VR1610	VR1525	
 Small Parts Machining	TNGG160402R/L-F	0.1-1.5	0.05-0.15									○	●	●	○		
	TNGG160404R/L-F	0.2-2	0.05-0.2							○	●	●	○				
	TNGG160408R/L-F	0.4-2.5	0.05-0.2							○	●	●	○				

Note: ●Recommended grade ready to stock

## Negative Inserts

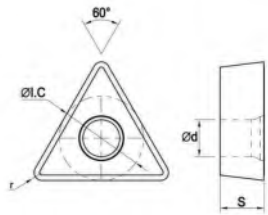

Length	Size(mm)			
	IC	S	d	r
16	9.525	4.76	3.81	0.2-0.8

60° TN□□ With Hole

Shape	Type	ap (mm)	f (mm/rev)	Grade													
				CVD						PVD							
				VK3020	VK3040	VK3115	VK4415	VK4425	VK4435	VK1605	VK1820	VK1625	VK1830	VK1828	VR1610	VR1525	
 Small Parts Machining	TNGG160402R/L-M	0.2-2	0.05-0.12							○	●	●	○				
	TNGG160404R/L-M	0.2-2.5	0.08-0.25							○	●	●	○				
	TNGG160408R/L-M	0.3-3	0.1-0.3							○	●	●	○				

Note: ●Recommended grade ready to stock

## Negative Inserts

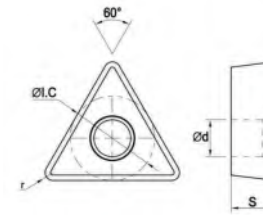

Length	Size(mm)			
	IC	S	d	r
08	4.76	2.38	2.3	0.2-0.4
09	5.56	2.38	2.8	0.2-0.4
11	6.35	3.18	3.18	0.2-0.4

60° TP□□ With Hole

Shape	Type	ap (mm)	f (mm/rev)	Grade													
				CVD						PVD							
				VK3020	VK3040	VK3115	VK4415	VK4425	VK4435	VK1605	VK1820	VK1625	VK1830	VK1828	VR1610	VR1525	
 Small Parts Machining	TPGH080202R/L	0.2-1	0.02-0.1									○	●	●	○		
	TPGH080204R/L	0.4-1.5	0.05-0.1							○	●	●	○				
	TPGH090202R/L	0.2-1	0.02-0.1							○	●	●	○				
	TPGH090204R/L	0.4-1.5	0.05-0.1							○	●	●	○				
	TPGH110302R/L	0.2-1.5	0.02-0.15							○	●	●	○				
	TPGH110304R/L	0.4-1.5	0.05-0.15							○	●	●	○				

Note: ●Recommended grade ready to stock





## Train Wheel Turning Inserts

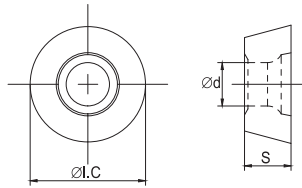

Length	Size(mm)		
	IC	S	d
8	8	3.18	3.36
10	10	3.18	4.4
12	12.7	4.76	4.4
16	16	6.35	5.5
20	20	6.35	6.5
25	25	7.94	7.2
32	32	9.52	9.5

RC□□ With Hole

Shape	Type	ap (mm)	f (mm/rev)	Grade																
				CVD							PVD									
				VK3020	VK3040	VK3115	VK4415	VK4425	VK4435	VK1025	VK1525	VK1825	VK1824	VK1828	VR1610	VR1525				
 Train Wheel Profiling	RCMX0803MO	0.50-3.00	0.15-0.40				●	○												
	RCMX1003MO	1.50-4.00	0.25-0.50				●	○												
	RCMX1204MO	2.50-5.00	0.30-0.60				●	○												
	RCMX1606MO	3.00-7.00	0.40-0.75				●	○												
	RCMX2006MO	3.50-9.00	0.48-0.90				●	○												
	RCMX2507MO	4.00-12.00	0.55-1.20				●	○												
	RCMX3209MO	5.00-15.00	0.65-1.50				●	○												

Note: ●Recommended grade ready to stock

## Train Wheel Turning Inserts

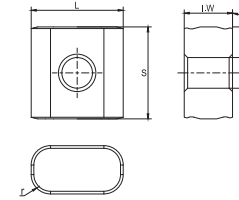

Length	Size(mm)				
	L	I.W	S	d	r
19	19.05	10	19.05	6.35	4

Shape	Type	ap (mm)	f (mm/rev)	Grade																
				CVD							PVD									
				VK3020	VK3040	VK3115	VK4415	VK4425	VK4435	VK1025	VK1525	VK1825	VK1824	VK1828	VR1610	VR1525				
 Train Wheel Trimming	175.32-191940-22	2.00-5.00	0.20-0.60				●	○												

Note: ●Recommended grade ready to stock

## Train Wheel Turning Inserts

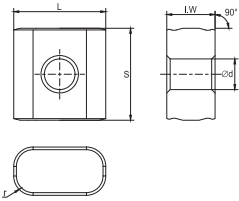

Length	Size(mm)				
	L	I.W	S	d	r
19	19.05	10	19.05	6.35	4

## Train Wheel Turning Inserts

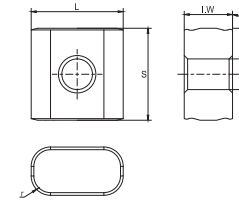

Length	Size(mm)				
	L	I.W	S	d	r
19	19.05	10	19.05	6.35	4

Shape	Type	ap (mm)	f (mm/rev)	Grade																				
				CVD						PVD														
				VK3020	VK3040	VK3115	VK4415	VK4425	VK4435	VK1025	VK1525	VK1825	VK1824	VK1828	VR1610	VR1525								
 Train Wheel Trimming	175.32-191940-24	2.00-5.00	0.20-0.60				●	○																

Note: ●Recommended grade ready to stock

Shape	Type	ap (mm)	f (mm/rev)	Grade																				
				CVD						PVD														
				VK3020	VK3040	VK3115	VK4415	VK4425	VK4435	VK1025	VK1525	VK1825	VK1824	VK1828	VR1610	VR1525								
 Train Wheel Trimming	175.32-191940-28	2.00-5.00	0.20-0.60				●	○																

Note: ●Recommended grade ready to stock

WECAN  
CUTTING TOOLS

## Parting Grooving Tools

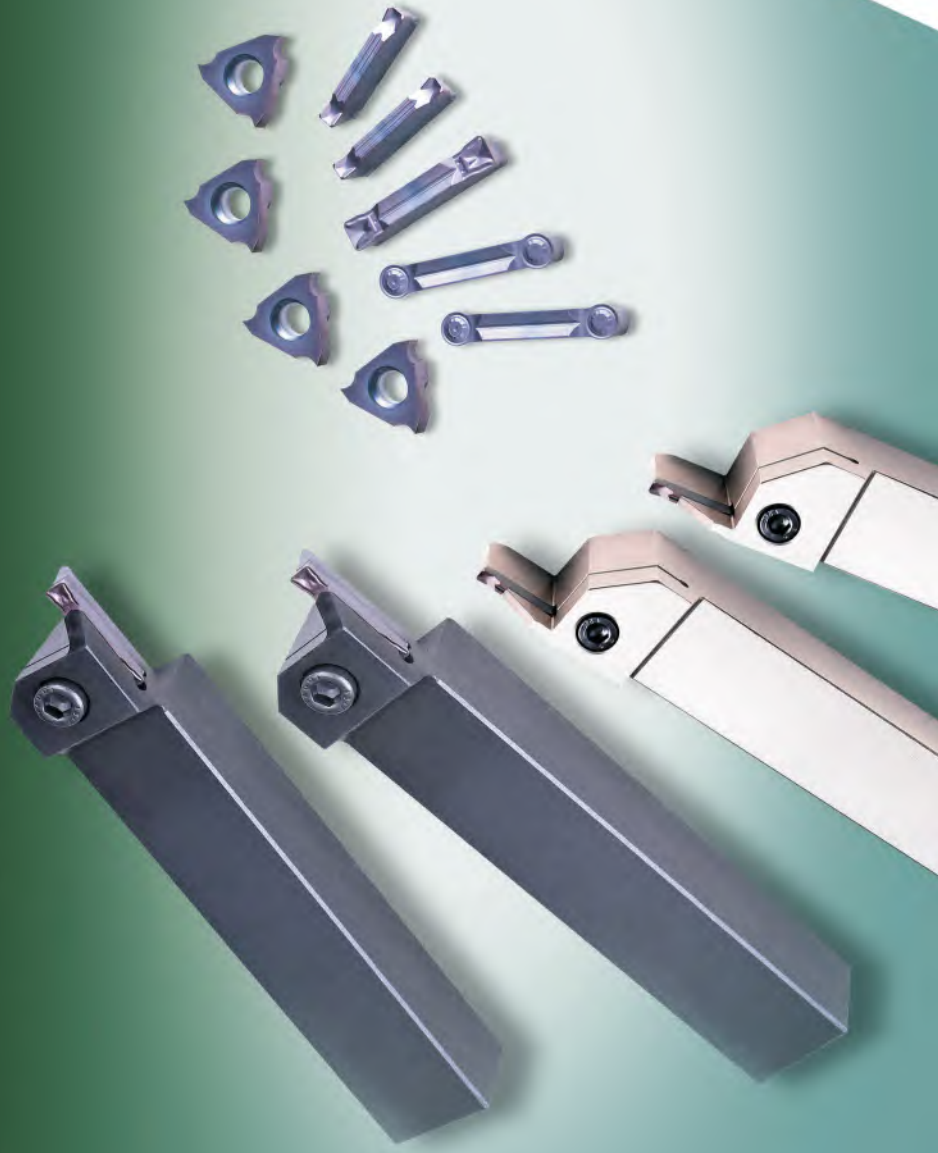

## Parting and Grooving Inserts

### Naming Rules

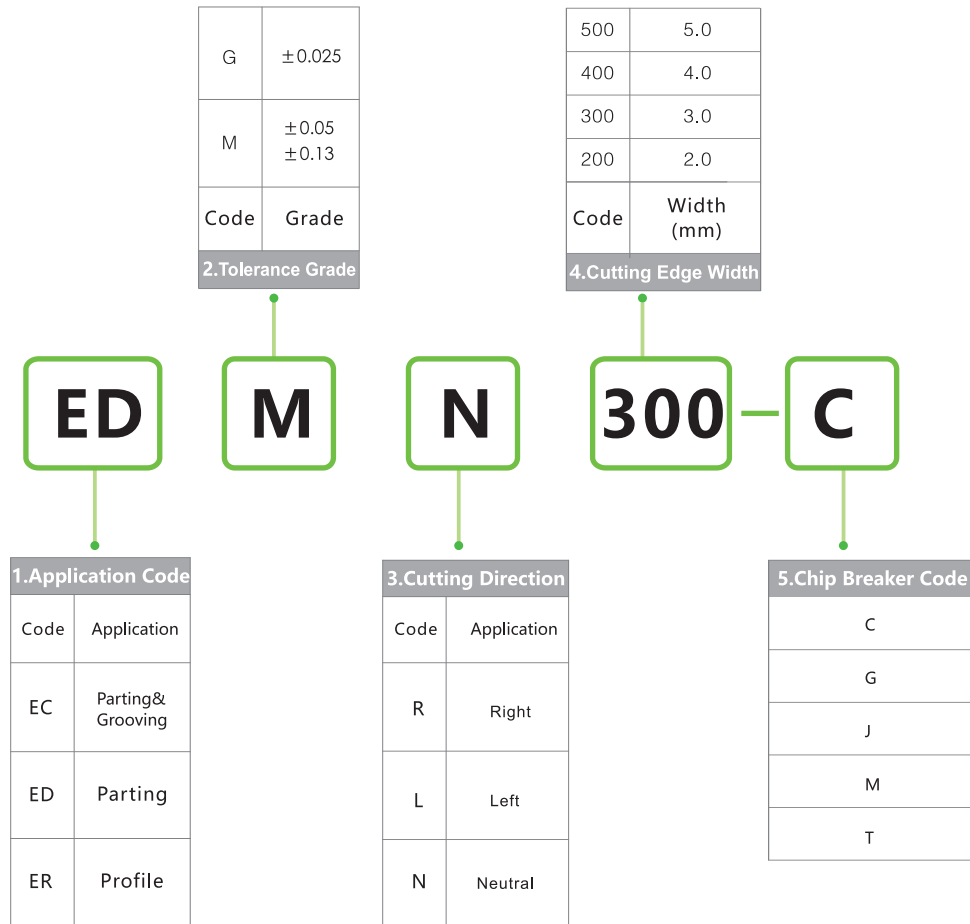

## Parting and Grooving Inserts

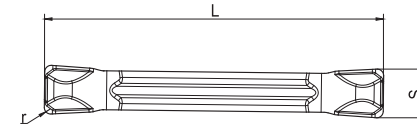

Width	Size (mm)		
	S	r±0.1	L
200	2.0	0.2	20
300	3.0	0.4	20
400	4.0	0.4	20
500	5.0	0.4	25

Shape	Type	f (mm/rev)	Grade											
			CVD						PVD					
			VK3020	VK3040	VK3115	VK4415	VK4425	VK4435	VK1025	VK1525	VK1825	VK1824	VK1828	VR1610
	EDMN200-C	0.05-0.18					●	○	●	●				
	EDMN300-C	0.07-0.25					●	○	●	●				
	EDMN400-C	0.08-0.30					●	○	●	●				
	EDMN500-C	0.09-0.35					●	○	●	●				

Note: ● Recommended grade ready to stock

## Parting and Grooving Inserts

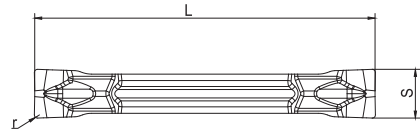

Width	Size(mm)		
	S	r±0.1	L
200	2.0	0.2	20
300	3.0	0.4	20
400	4.0	0.4	20
500	5.0	0.4	25

Shape	Type	f (mm/rev)	Grade													
			CVD						PVD							
			VK3020	VK3040	VK3115	VK4415	VK4425	VK4435	VK1025	VK1525	VK1825	VK1824	VK1828	VR1610	VR1525	
	EDMN200-J	0.04-0.12					●	○	●	●						
	EDMN300-J	0.04-0.16					●	○	●	●						
	EDMN400-J	0.05-0.18					●	○	●	●						
	EDMN500-J	0.05-0.20					●	○	●	●						

Note: ●Recommended grade ready to stock

## Parting and Grooving Inserts

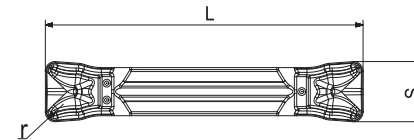

Width	Size(mm)		
	S	r±0.1	L
300	3.0	0.4	21.1
400	4.0	0.8	26.4
500	5.0	0.8	27.2
600	6.0	0.8	27.5

Shape	Type	f (mm/rev)	Grade													
			CVD						PVD							
			VK3020	VK3040	VK3115	VK4415	VK4425	VK4435	VK1025	VK1525	VK1825	VK1824	VK1828	VR1610	VR1525	
	ECMN300-T	0.05-0.18					●	○	●	●						
	ECMN400-T	0.07-0.25					●	○	●	●						
	ECMN500-T	0.08-0.3					●	○	●	●						
	ECMN600-T	0.09-0.35					●	○	●	●						

Note: ●Recommended grade ready to stock

## Parting and Grooving Inserts

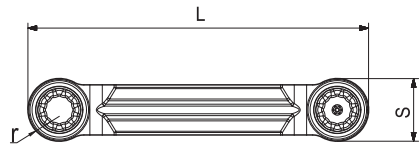

Width	Size(mm)		
	S	r±0.1	L
300	3.0	1.5	21.1
400	4.0	2	26.4
500	5.0	2.5	27.2
600	6.0	3	27.5

Shape	Type	f (mm/rev)	Grade														
			CVD						PVD								
			VK3020	VK3040	VK3115	VK4415	VK4425	VK4435	VK1025	VK1525	VK1825	VK1824	VK1828	VR1610	VR1525		
	ERMN300-T	0.05-0.18					●	○	●	●							
	ERMN400-T	0.07-0.25					●	○	●	●							
	ERMN500-T	0.08-0.3					●	○	●	●							
	ERMN600-T	0.09-0.35					●	○	●	●							

Note: ●Recommended grade ready to stock

## Parting and Grooving Inserts

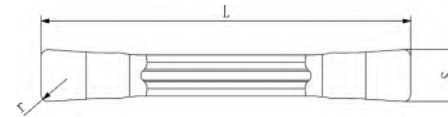

Width	Size(mm)		
	S	r±0.1	L
200	2.0	0.2	21
300	3.0	0.4	21
400	4.0	0.4	21
500	5.0	0.4	26

Shape	Type	f (mm/rev)	Grade														
			CVD						PVD								
			VK3020	VK3040	VK3115	VK4415	VK4425	VK4435	VK1025	VK1525	VK1825	VK1824	VK1828	VR1610	VR1525		
	MGGN200-GL	0.05-0.18					●	○	●	●							
	MGGN300-GL	0.07-0.25					●	○	●	●							
	MGGN400-GL	0.08-0.3					●	○	●	●							
	MGGN500-GL	0.09-0.35					●	○	●	●							

Note: ●Recommended grade ready to stock

## Parting and Grooving Inserts



Width	Size(mm)		
	S	r±0.1	L
200	2.0	1.0	16.0
300	3.0	1.5	21.0
400	4.0	2.0	21.0
500	5.0	2.5	26.0
600	6.0	3.0	26.0
800	8.0	4.0	31.0

Shape	Type	f (mm/rev)	Grade												
			CVD						PVD						
			VK3020	VK3040	VK3115	VK4415	VK4425	VK4435	VK1025	VK1525	VK1825	VK1824	VK1828	VR1610	VR1525
	ERMN200-M	0.05-0.15					●	○	●	●					
	ERMN300-M	0.08-0.18					●	○	●	●					
	ERMN400-M	0.10-0.20					●	○	●	●					
	ERMN500-M	0.12-0.23					●	○	●	●					
	ERMN600-M	0.15-0.27													
	ERMN800-M	0.18-0.35													

Note: ●Recommended grade ready to stock

## Grinded Grooving Inserts NEW

### Naming Rule

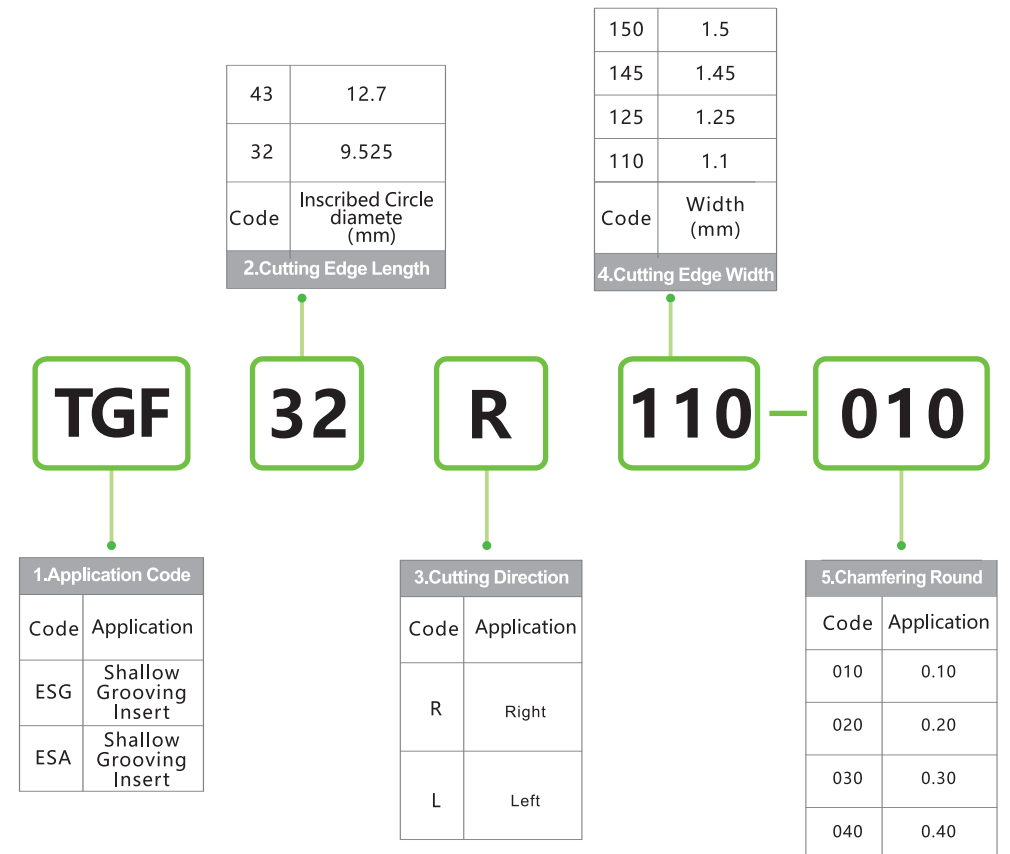

## Shallow Grooving Inserts

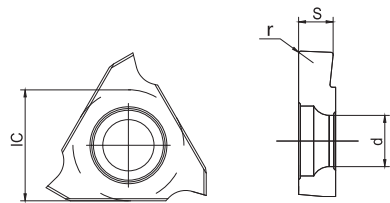

Width	Size(mm)			
	IC	S	d	r
110	9.525	1.10	4.4	0.1
125	9.525	1.25	4.4	0.1
145	9.525	1.45	4.4	0.1
150	9.525	1.50	4.4	0.1
175	9.525	1.75	4.4	0.1
185	9.525	1.85	4.4	0.1
200	9.525	2.00	4.4	0.1
250	9.525	2.50	4.4	0.1
300	9.525	3.00	4.4	0.1

Shape	Type	ap (max/mm)	Grade											
			CVD						PVD					
			VK3020	VK3040	VK3115	VK4415	VK4425	VK4435	VK1605	VK1820	VK1625	VK1830	VK1828	VR1610
	TGF32R/L033-005	0.80						○	●	●	○			
	TGF32R/L050-005	1.20						○	●	●	○			
	TGF32R/L075-010	2.00						○	●	●	○			
	TGF32R/L095-010	2.00						○	●	●	○			
	TGF32R/L100-010	2.00						○	●	●	○			
	TGF32R/L110-010	2.00						○	●	●	○			
	TGF32R/L125-010	2.00						○	●	●	○			
	TGF32R/L145-010	2.50						○	●	●	○			
	TGF32R/L150-010	2.50						○	●	●	○			
	TGF32R/L175-010	2.50						○	●	●	○			
	TGF32R/L185-010	2.50						○	●	●	○			
	TGF32R/L200-010	2.50						○	●	●	○			
	TGF32R/L250-010	2.50						○	●	●	○			
TGF32R/L300-010	2.50						○	●	●	○				

Note: ●Recommended grade ready to stock

## Shallow Grooving Inserts

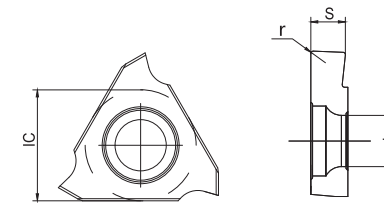

Width	Size(mm)			
	IC	S	d	r
125	12.7	1.25	4.4	0.1
125	12.7	1.25	4.4	0.2
150	12.7	1.50	4.4	0.1
150	12.7	1.50	4.4	0.2
200	12.7	2.00	4.4	0.1
200	12.7	2.50	4.4	0.2
250	12.7	2.50	4.4	0.1
250	12.7	2.50	4.4	0.2
300	12.7	3.00	4.4	0.1
300	12.7	3.00	4.4	0.2

Shape	Type	ap (max/mm)	Grade											
			CVD						PVD					
			VK3020	VK3040	VK3115	VK4415	VK4425	VK4435	VK1605	VK1820	VK1625	VK1830	VK1828	VR1610
	GBA43R/L125-010	2.00						○	●	●	○			
	GBA43R/L125-020							○	●	●	○			
	GBA43R/L150-010	3.50						○	●	●	○			
	GBA43R/L150-020							○	●	●	○			
	GBA43R/L200-010							○	●	●	○			
	GBA43R/L200-020	4.00						○	●	●	○			
	GBA43R/L250-010							○	●	●	○			
	GBA43R/L250-020							○	●	●	○			
	GBA43R/L300-010							○	●	●	○			
	GBA43R/L300-020						○	●	●	○				

Note: ●Recommended grade ready to stock

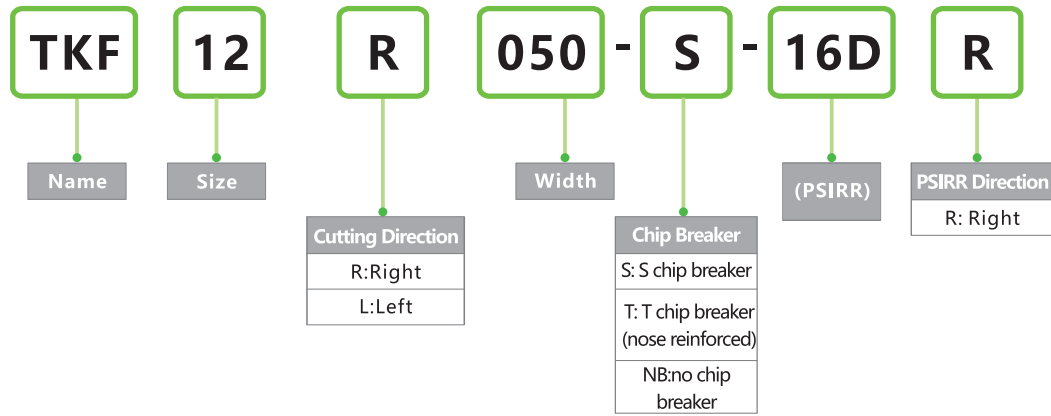

## Special Parting Inserts

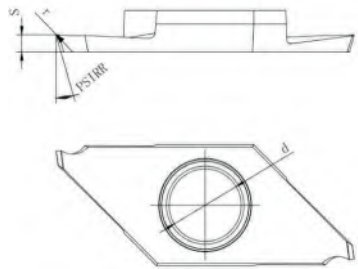

Width	Size(mm)			
	PSIRR	S	d	r
50	16°	0.50	5.2	0.03
70		0.70	5.2	0.03
100		1.00	5.2	0.03
125		1.25	5.2	0.03
150		1.50	5.2	0.03
200		2.00	5.2	0.03
50	0°	0.50	5.2	0.03
70		0.70	5.2	0.03
100		1.00	5.2	0.03
125		1.25	5.2	0.03
150		1.50	5.2	0.03
200		2.00	5.2	0.03
100	16°	1.00	5.2	0.08
150		1.50	5.2	0.08
200		2.00	5.2	0.08
100	0°	1.00	5.2	0.08
150		1.50	5.2	0.08
200		2.00	5.2	0.08

Shape	Type	ap (max/mm)	Grade													
			CVD						PVD							
			VK3020	VK3040	VK3115	VK4415	VK4425	VK4435	VK1605	VK1820	VK1625	VK1830	VR1828	VR1610	VR1525	
	TKF12R/L050-S-16DR	5.00							○	●	●	○				
	TKF12R/L070-S-16DR	8.00							○	●	●	○				
	TKF12R/L100-S-16DR	12.00							○	●	●	○				
	TKF12R/L125-S-16DR	12.00							○	●	●	○				
	TKF12R/L150-S-16DR								○	●	●	○				
	TKF12R/L200-S-16DR									○	●	●	○			
	TKF12R/L050-S	5.00							○	●	●	○				
	TKF12R/L070-S	8.00							○	●	●	○				
	TKF12R/L100-S	12.00							○	●	●	○				
	TKF12R/L125-S								○	●	●	○				
	TKF12R/L150-S									○	●	●	○			
	TKF12R/L200-S									○	●	●	○			
	TKF12R/L100-T-16DR									○	●	●	○			
	TKF12R/L150-T-16DR									○	●	●	○			
	TKF12R/L200-T-16DR									○	●	●	○			
	TKF12R/L100-T									○	●	●	○			
	TKF12R/L150-T									○	●	●	○			
	TKF12R/L200-T								○	●	●	○				

Note: ● Recommended grade ready to stock

## Special Parting Inserts

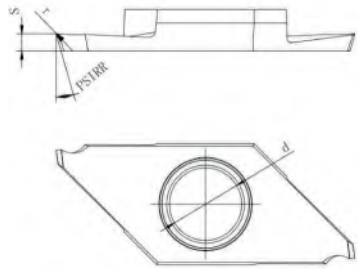

Width	Size(mm)			
	PSIRR	S	d	r
150	16°	1.50	5.2	0.05
200		2.00	5.2	0.05
150		1.50	5.2	0.05
200		2.00	5.2	0.05
150		1.50	5.2	0.08
200		2.00	5.2	0.08
150	0°	1.50	5.2	0.08
200		2.00	5.2	0.08

Shape	Type	ap (max/mm)	Grade													
			CVD						PVD							
			VK3020	VK3040	VK3115	VK4415	VK4425	VK4435	VK1605	VK1820	VK1625	VK1830	VK1828	VR1610	VR1525	
	TKF16R/L150-S-16DR	16.00							○	●	●	○				
	TKF16R/L200-S-16DR								○	●	●	○				
	TKF16R/L150-S								○	●	●	○				
	TKF16R/L150-S								○	●	●	○				
	TKF16R/L150-T-16DR								○	●	●	○				
	TKF16R/L200-T-16DR								○	●	●	○				
	TKF16R/L150-T								○	●	●	○				
	TKF16R/L200-T								○	●	●	○				

Note: ● Recommended grade ready to stock

# Threading Inserts

## Naming Rules

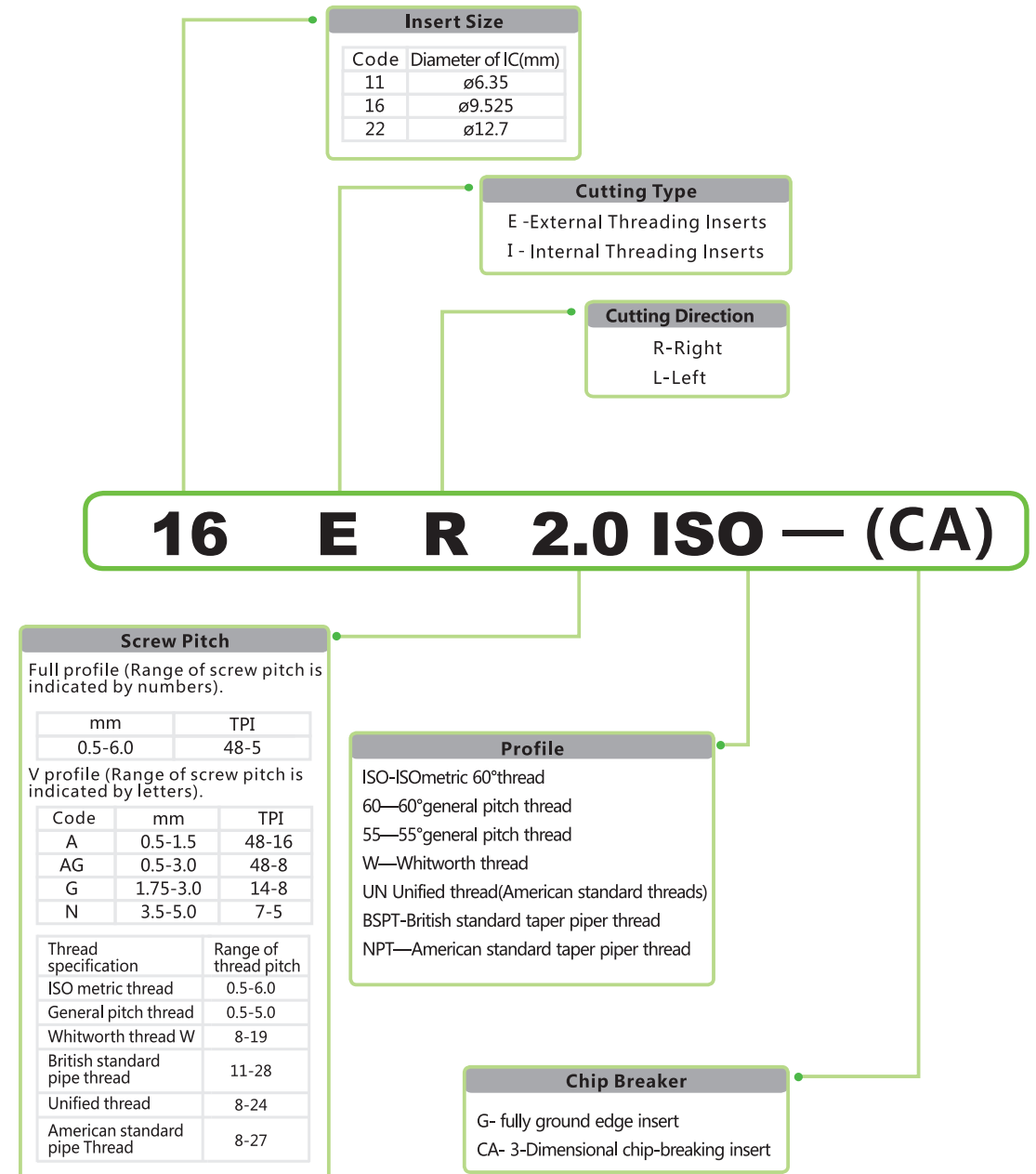

## ISO Metric Thread

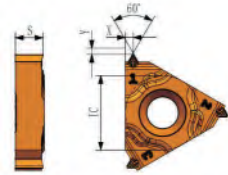
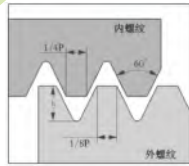

Standard:R262(DIN 13) Tolerance Class:6g/6H

★With End

Shape	Type	Range of Thread Pitch		Insert Dimestions(mm)				Coating	
		mm	pitch/inch	IC	S	X	Y	VK1825	VK1520
	16ER1.00ISO-CA	1		9.525	3.52	0.7	0.6	●	○
	16ER1.25ISO-CA	1.25		9.525	3.52	0.9	0.7	●	○
	16ER1.50ISO-CA	1.5		9.525	3.52	1	0.8	●	○
	16ER1.75ISO-CA	1.75		9.525	3.52	1.1	0.9	●	○
	16ER2.00ISO-CA	2		9.525	3.52	1.2	0.9	●	○
	16ER2.50ISO-CA	2.5		9.525	3.52	1.5	1.1	●	○
	16ER3.00ISO-CA	3		9.525	4.65	1.7	1.2	●	○
	16IR1.00ISO-CA	1		9.525	3.52	0.7	0.6	●	○
	16IR1.25ISO-CA	1.25		9.525	3.52	0.8	0.6	●	○
	16IR1.50ISO-CA	1.5		9.525	3.52	0.9	0.7	●	○
	16IR1.75ISO-CA	1.75		9.525	3.52	1	0.8	●	○
	16IR2.00ISO-CA	2		9.525	3.52	1.1	0.8	●	○
	16IR2.50ISO-CA	2.5		9.525	3.52	1.4	1	●	○
	16IR3.00ISO-CA	3		9.525	4.65	1.5	1.1	●	○

Note: ●Recommended grade ready to stock

## ISO Metric Thread

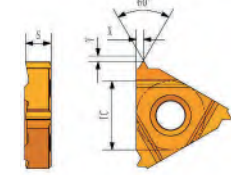
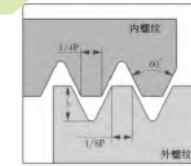

Standard:R262(DIN 13) Tolerance Class:6g/6H

★With End

Shape	Type	Range of Thread Pitch		Insert Dimestions(mm)				Coating	
		mm	pitch/inch	IC	S	X	Y	VK1825	VK1520
	16ER1.00ISO-G	1		9.525	3.52	0.7	0.6	●	○
	16ER1.25ISO-G	1.25		9.525	3.52	0.9	0.7	●	○
	16ER1.50ISO-G	1.5		9.525	3.52	1	0.8	●	○
	16ER1.75ISO-G	1.75		9.525	3.52	1.1	0.9	●	○
	16ER2.00ISO-G	2		9.525	3.52	1.2	0.9	●	○
	16ER2.50ISO-G	2.5		9.525	3.52	1.5	1.1	●	○
	16ER3.00ISO-G	3		9.525	4.65	1.7	1.2	●	○
	22ER3.50ISO-G	3.5		12.7	4.65	2.3	1.6	●	○
	22ER4.00ISO-G	4		12.7	4.65	2.3	1.6	●	○
	22ER4.50ISO-G	4.5		12.7	4.65	2.4	1.7	●	○
	22ER5.00ISO-G	5		12.7	4.65	2.5	1.7	●	○
	11IR1.00ISO-G	1		6.35	3.05	0.7	0.6	●	○
	11IR1.25ISO-G	1.25		6.35	3.05	0.9	0.8	●	○
	11IR1.50ISO-G	1.5		6.35	3.05	1	0.8	●	○
	11IR1.75ISO-G	1.75		6.35	3.05	1.1	0.9	●	○
	11IR2.00ISO-G	2		6.35	3.05	1.1	0.9	●	○
		16IR1.00ISO-G	1		9.525	3.52	0.7	0.6	●
16IR1.25ISO-G		1.25		9.525	3.52	0.8	0.6	●	○
16IR1.50ISO-G		1.5		9.525	3.52	0.9	0.7	●	○
16IR1.75ISO-G		1.75		9.525	3.52	1	0.8	●	○
16IR2.00ISO-G		2		9.525	3.52	1.1	0.8	●	○
16IR2.50ISO-G		2.5		9.525	3.52	1.4	1	●	○
16IR3.00ISO-G		3		9.525	4.65	1.5	1.1	●	○
22IR3.50ISO-G		3.5		12.7	4.65	2.3	1.6	●	○
22IR4.00ISO-G		4		12.7	4.65	2.3	1.6	●	○
22IR4.50ISO-G		4.5		12.7	4.65	2.4	1.7	●	○
22IR5.00ISO-G	5		12.7	4.65	2.5	1.7	●	○	

Note: ●Recommended grade ready to stock

## 55°/60° General Pitch Thread

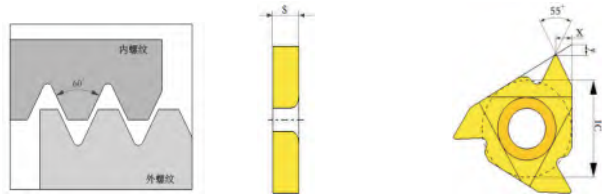

★Without End

Shape	Type	Range of Thread Pitch		Insert Dimensions(mm)				Coating	
		mm	pitch/inch	IC	S	X	Y	VK1825	VK1520
	16ERA55	0.5-1.5	48-16	9.525	3.52	0.9	0.8	●	○
	16ERAG55	0.5-3.0	48-8	9.525	3.52	1.7	1.2	●	○
	16ERG55	1.75-3.0	14-8	9.525	3.52	1.7	1.2	●	○
	22ERN55	3.5-5.0	7-5	12.7	4.65	2.5	1.7	●	○
	11IRA55	0.5-1.5	48-16	6.35	3.52	0.9	0.8	●	○
	16IRA55	0.5-1.5	48-16	9.525	3.52	0.9	0.8	●	○
	16IRAG55	0.5-3.0	48-8	9.525	3.52	1.7	1.2	●	○
	16IRG55	1.75-3.0	14-8	9.525	3.52	1.7	1.2	●	○
	22IRN55	3.5-5.0	7-5	12.7	4.65	2.5	1.7	●	○

Shape	Type	Range of Thread Pitch		Insert Dimensions(mm)				Coating	
		mm	pitch/inch	IC	S	X	Y	VK1825	VK1520
	16ERA60	0.5-1.5	48-16	9.525	3.52	0.9	0.8	●	○
	16ERAG60	0.5-3.0	48-8	9.525	3.52	1.7	1.2	●	○
	16ERG60	1.75-3.0	14-8	9.525	3.52	1.7	1.2	●	○
	22ERN60	3.5-5.0	7-5	12.7	4.65	2.5	1.7	●	○
	11IRA60	0.5-1.5	48-16	6.35	3.52	0.9	0.8	●	○
	16IRA60	0.5-1.5	48-16	9.525	3.52	0.9	0.8	●	○
	16IRAG60	0.5-3.0	48-8	9.525	3.52	1.7	1.2	●	○
	16IRG60	1.75-3.0	14-8	9.525	3.52	1.7	1.2	●	○
	22IRN60	3.5-5.0	7-5	12.7	4.65	2.5	1.7	●	○

Note: ●Recommended grade ready to stock

## Whitworth Thread

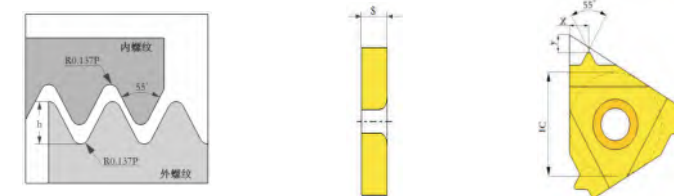

★With End

Standard: B.S.84: 1956, DIN259, ISO288/1:1982  
Tolerance class: Medium class A

Shape	Type	Range of Thread Pitch		Insert Dimensions(mm)				Coating	
		mm	pitch/inch	IC	S	X	Y	VK1825	VK1520
	16ER8W		8	9.525	3.52	1.5	1.2	●	○
	16ER9W		9	9.525	3.52	1.7	1.2	●	○
	16ER10W		10	9.525	3.52	1.5	1.1	●	○
	16ER11W		11	9.525	3.52	1.5	1.1	●	○
	16ER12W		12	9.525	3.52	1.4	1.1	●	○
	16ER14W		14	9.525	3.52	1.2	1	●	○
	16ER16W		16	9.525	3.52	1.1	0.9	●	○
	16ER18W		18	9.525	3.52	1	0.8	●	○
	16ER19W		19	9.525	3.52	1	0.8	●	○
	16IR8W		8	9.525	3.52	1.5	1.2	●	○
	16IR9W		9	9.525	3.52	1.7	1.2	●	○
	16IR10W		10	9.525	3.52	1.5	1.1	●	○
	16IR11W		11	9.525	3.52	1.5	1.1	●	○
	16IR12W		12	9.525	3.52	1.4	1.1	●	○
	16IR14W		14	9.525	3.52	1.2	1	●	○
	16IR16W		16	9.525	3.52	1.1	0.9	●	○
	16IR18W		18	9.525	3.52	1	0.8	●	○
	16IR19W		19	9.525	3.52	1	0.8	●	○

Note: ●Recommended grade ready to stock

## British Standard Taper Piper Thread



Standard: B.S.21 : 1985  
Tolerance class: BSPT

★With End

Shape	Type	Range of Thread Pitch		Insert Dimensions(mm)				Coating	
		mm	pitch/inch	IC	S	X	Y	VK1825	VK1520
	16ER11BSPT		11	9.525	3.52	1.5	1.1	●	○
	16ER14BSPT		14	9.525	3.52	1.2	1	●	○
	16ER19BSPT		19	9.525	3.52	0.9	0.8	●	○
	16ER28BSPT		28	9.525	3.52	0.6	0.6	●	○
	16IR11BSPT		11	9.525	3.52	1.5	1.1	●	○
	16IR14BSPT		14	9.525	3.52	1.2	1	●	○
	16IR19BSPT		19	9.525	3.52	0.9	0.8	●	○
	16IR28BSPT		28	9.525	3.52	0.6	0.6	●	○

Note: ●Recommended grade ready to stock

## Unified Thread

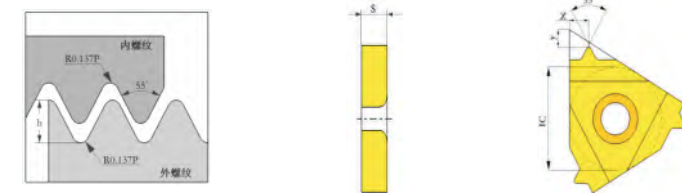

Standard: ANSI B1.1:74  
Tolerance class: 2A/2B

★With End

Shape	Type	Range of Thread Pitch		Insert Dimensions(mm)				Coating	
		mm	pitch/inch	IC	S	X	Y	VK1825	VK1520
	16ER8UN		8	9.525	3.52	1.6	1.2	●	○
	16ER10UN		10	9.525	3.52	1.5	1.1	●	○
	16ER12UN		12	9.525	3.52	1.4	1.1	●	○
	16ER14UN		14	9.525	3.52	1.2	1	●	○
	16ER16UN		16	9.525	3.52	1.1	0.9	●	○
	16ER18UN		18	9.525	3.52	1	0.8	●	○
	16ER20UN		20	9.525	3.52	0.9	0.8	●	○
	16ER24UN		24	9.525	3.52	0.8	0.7	●	○
	16IR8UN		8	9.525	3.52	1.5	1.1	●	○
	16IR10UN		10	9.525	3.52	1.5	1.1	●	○
	16IR12UN		12	9.525	3.52	1.4	1.1	●	○
	16IR14UN		14	9.525	3.52	1.2	0.9	●	○
	16IR16UN		16	9.525	3.52	1.1	0.9	●	○
	16IR18UN		18	9.525	3.52	1	0.8	●	○
	16IR20UN		20	9.525	3.52	0.9	0.8	●	○
	16IR24UN		24	9.525	3.52	0.8	0.7	●	○

Note: ●Recommended grade ready to stock

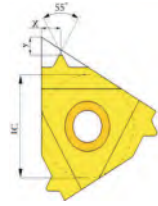
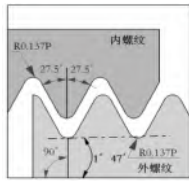

# A Turning Inserts

## American Standard Taper Piper Thread



Standard: USAS B.21:1968  
Tolerance class: NPT

★With End

Shape	Type	Range of Thread Pitch		Insert Dimestions(mm)				Coating	
		mm	pitch/inch	IC	S	X	Y	VK1825	VK1520
	16ER8NPT		8	9.525	3.52	1.8	1.3	●	○
	16ER11.5NPT		11.5	9.525	3.52	1.5	1.1	●	○
	16ER14NPT		14	9.525	3.52	1.2	0.9	●	○
	16ER18NPT		18	9.525	3.52	1	0.8	●	○
	16ER27NPT		27	9.525	3.52	0.8	0.7	●	○
	16IR8NPT		8	9.525	3.52	1.8	1.3	●	○
	16IR11.5NPT		11.5	9.525	3.52	1.5	1.1	●	○
	16IR14NPT		14	9.525	3.52	1.2	0.9	●	○
	16IR18NPT		18	9.525	3.52	1	0.8	●	○
	16IR27NPT		27	9.525	3.52	0.8	0.7	●	○

Note: ●Recommended grade ready to stock

# Milling Inserts



# Turbocharger

Due to fuel saving, power, environmental protection and other reasons, turbochargers are increasingly widely used, becoming an indispensable part of the internal combustion engine. Turbocharger shell is the most important part of the turbocharger, the material is mostly made of high temperature resistant alloy material, e.g. 1.4826, 1.4837, 1.4848, 1.4849 etc.

Our technical team is committed to developing new cutting tool materials, insert chip breakers and coatings. Currently, we are able to provide the perfect solution for different conditions for the machining of turbocharger housings from roughing to finishing.



## Application No.1



XN07 is a heptagonal face milling cutter, 14 effective cutting edges, rough milling of flange planes, excellent cost performance

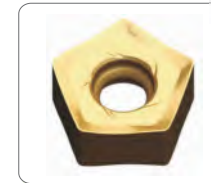

PN09 is for finish milling of turbine shell flange plane with good surface cleanliness



CN12 is for rough machining of external and internal boring of turbine casing.



## Application No.2



DN15 is for internal Finish boring for turbine shell



SN09 is for back milling of flanges.



SD09 is for internal plane machining.



## Case No.1

Workpiece material:heat-resisting steels  
 Workpiece:Turbine shell  
 Cooling type:Compressed Air  
 Original blade:A foreign brand  
 WeCan insert:ONHU050408-AF VR1028  
 Cutting parameter:Vc:168m/min fz:0.07mm/z ap:2.3mm  
 Conclusion: Our inserts cutting light and fast, low cutting force, even wear on the rear surface, compared with a foreign brand processing life of 15 pieces / edge, our products are more cost-effective.

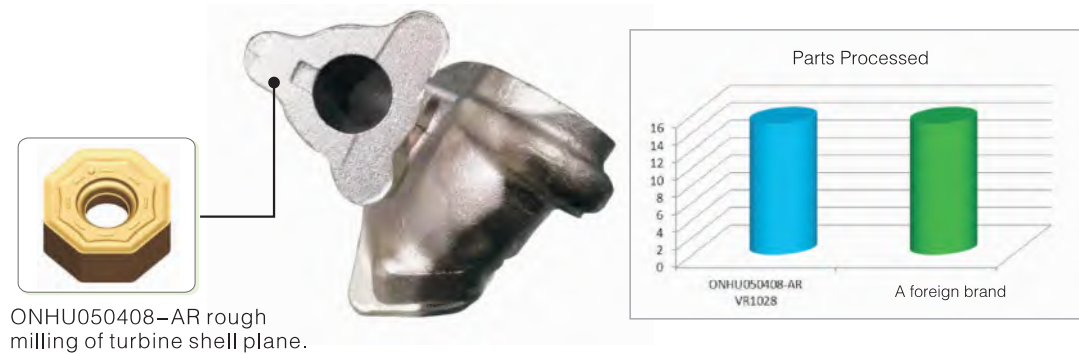

## Case No.2

Workpiece material:heat-resisting steels 1.4837  
 Workpiece:Turbine shell  
 Cooling type:Cooling Liquid  
 Original blade:A foreign brand  
 WeCan insert:XNGU0705ANN-GR VR1028  
 Cutting parameter:Vc:261.2m/min fz:0.08mm/z ap:1.5~2mm  
 Conclusion: Our inserts processed 32 pieces, a foreign brand processed 30 pieces, the tool life increased by 7% with good cost performance.

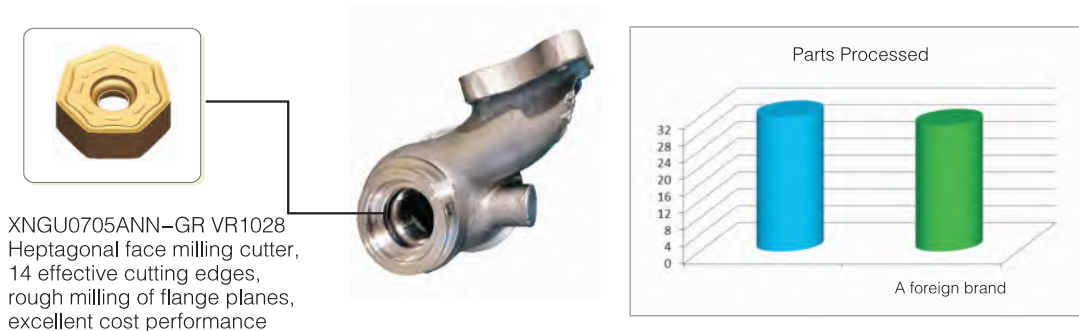

## Case No.3

Workpiece material:heat-resisting steels 1.4837  
 Workpiece:Turbine shell  
 Cooling type:Compressed Air  
 Original blade:A foreign brand  
 WeCan insert:CNMG120412-DM VR1025  
 Cutting parameter:Boring:Vc:111m/min fz:0.18 mm/rev ap:1.75mm  
 End face:Vc:120m/min fz:0.15mm/rev ap:1.3mm  
 Service life:3 pieces/edge  
 Conclusion: Used for turbine shell boring and end face rough machining, and end face for intermittent processing, our inserts can process 3 pieces, a foreign brand processed 2 pieces, and successfully replaced



## Case No.4

Workpiece material:heat-resisting steels 1.4837  
 Workpiece: Turbine shell  
 Cooling type:Cooling Liquid  
 Original blade:A foreign brand  
 WeCan insert:DNMG150404-DM VR1025  
 Cutting parameter: Vc: 130m/min fz=0.1 mm/rev ap=0.2mm  
 Service life:5 pieces/edge  
 Conclusion: Used in the turbine casing boring and end face finishing, our inserts processed 5 pieces, a foreign brand processed 5 pieces, the single cost per piece of workpiece processing is low, and our insert's rear tool surface wear less than competitor's



## SHARK TOOTH - Milling Insert for Turbine Blades

### 1 Steam Turbine Blade Material and Its Characteristics

Blade often use high strength, toughness, good thermal hardness of heat-resistant stainless steel, mechanical processing is difficult as follows

- Large machining allowance, in order to improve production efficiency, cutting with the highest possible cutting parameters
- High strength, high cutting force, high machining temperature, fast tool wear, easy to chipping
- Severe machining hardening, high tool groove wear

### 2 Grade Features of VR1029

- Stronger bonding phase, higher resistance to plastic deformation and wear resistance, and excellent toughness
- High aluminum content gradient nano-coating for increased oxidation resistance and cutting temperature
- Smooth product surface to prevent chip tumor accumulation
- Higher economic efficiency.



### Case No.1

Workpiece material: 2Cr12NiMo1W1V  
 Workpiece: High pressure cylinder stage 12 dynamic and locking lobe  
 Cooling type: Compressed Air  
 Processing type: Rough milling of airway profiles  
 Original blade: A foreign brand  
 WeCan insert: RPMT1204M0 VR1028  
 Cutting parameter:  $V_c: 231\text{m/min}$   $f_z: 0.38\text{mm/z}$   $a_p: 1.5\text{mm}$   
 Conclusion: Our blade life is 4 pieces/edge, that is single piece for 16 workpieces. A foreign brand blade life is 2 pieces/edge. Our processing quantity is 200% of the foreign brand, and the cost is significantly reduced.

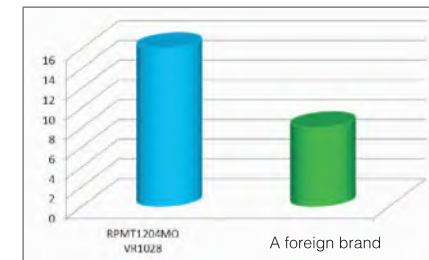
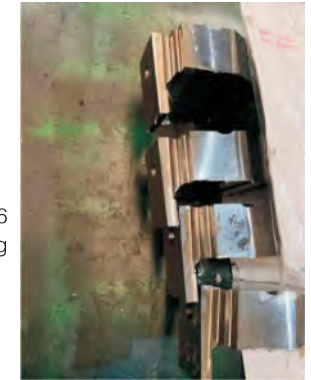

### Case No.2

Workpiece material: 10Cr11Co3W3NiMoVNB  
 Workpiece: High pressure level 5  
 Cooling type: Compressed Air  
 Processing type: Rough milling of airway profiles  
 Original blade: A foreign brand  
 WeCan insert: RPMT1204M0 VR1028  
 Cutting parameter:  $V_c: 221\text{m/min}$   $f_z: 0.51\text{mm/z}$   $a_p: 1.5\text{mm}$   
 Conclusion: Our blade life is 1 piece/edge, that is single piece for 4 workpieces. A foreign brand blade life is 1 piece/edge. Both are forced to change the blade after processing 1 piece. Our blade wear is smaller and the cost is reduced.

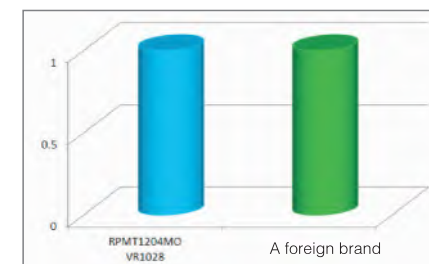
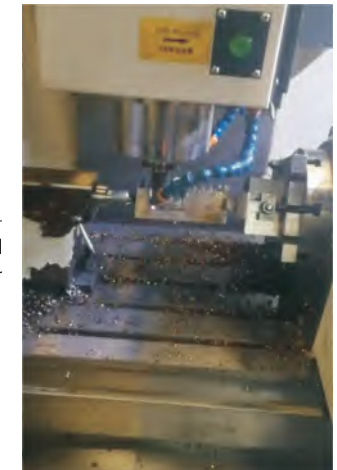

## HIGH FEED - Cyclone Milling

### 1. LNMU Series

#### Feature of Chip Breaker

- Double-sided fast feed, cost-effective with 4-edges
- Optimized edge preparation for machining steel, stainless steel, cast iron and high-temperature alloys, etc.
- Inserts Ap is up to 1mm and can be used for shoulder milling, groove milling, ramp milling and small depth milling.



#### Case :

Workpiece material: Alloy Steel  
 Workpiece: Cutter grooving  
 Cooling type: Compressed Air  
 Original blade: A foreign brand  
 WeCan insert: LNMU0303ZER-GM VK1025  
 Cutting parameter: Vc:126m/min, fz:0.3mm/z, ap:0.8mm  
 Conclusion: Our blade processed 46 pcs edge, a foreign brand processed 33 pcs edge, tool life increased by 40% to meet customers' cost-effective needs.

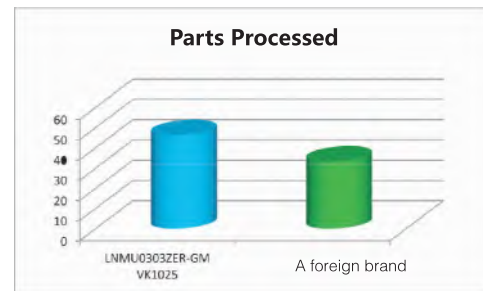

### 2. LOGU Series

#### Feature of Chip Breaker

- Double-sided with 4-edges
- Precision ground inserts for higher indexing accuracy
- Small-diameter and multi-edge for efficient machining, end mill diameter range 16-32mm



#### Case :

Workpiece material: 45# Steel  
 Workpiece: Automotive mold parts  
 Cooling type: Compressed Air  
 Original blade: A foreign brand  
 WeCan insert: LOGU030310ER-MM VK1825  
 Cutting parameter: Vc:180m/min, fz:0.77mm/z, ap:0.7mm  
 Conclusion: Our blade processed 3 pcs edge, a foreign brand processed 1 pcs edge, our blade efficiency increased by 4-5 times, the unit cost reduced by 5 times.

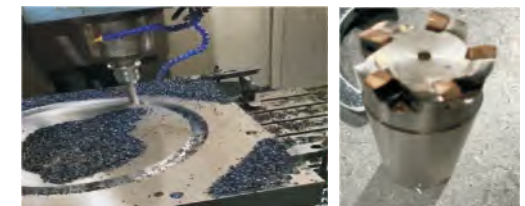
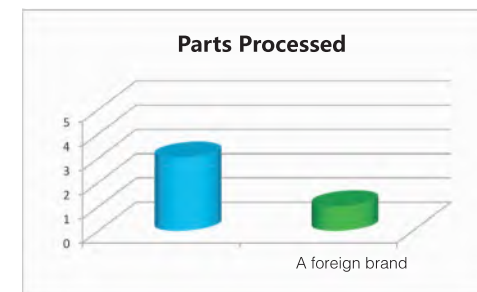

## HIGH FEED - New Application

### Replaces Traditional Round Milling Inserts

#### 3. SOMT Series

##### Feature of Chip Breaker

- Fast Feed for General Milling
- Convex cutting edge design inhibits impact during insert feed and improves the impact resistance of the insert.
- For flat surface machining, cavity machining and helical milling.

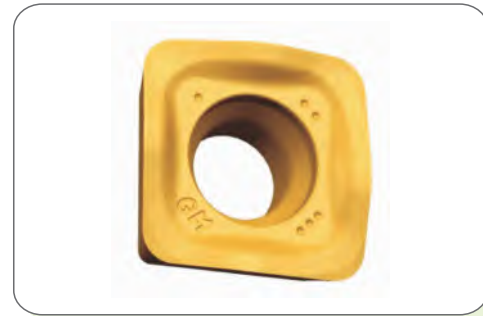

##### Case :

Workpiece material:SUS 431  
 Workpiece:Mask machine spinneret  
 Cooling type:Compressed Air  
 Original blade:A foreign brand–RPEW1003  
 Cutting parameter: Vc: 271 m/min, fz:0.91 mm/z, ap:0.3mm  
 WeCan insert:SOMT140520–GM VK1025  
 Cutting parameter: Vc: 178m/min, fz:1.23mm/z , ap:1mm  
 Conclusion: Fast feed inserts replace traditional round inserts, metal removal rate increased by 3.6 times per unit time, cutting performance increased by 300%, and tool cost reduced by 80%.

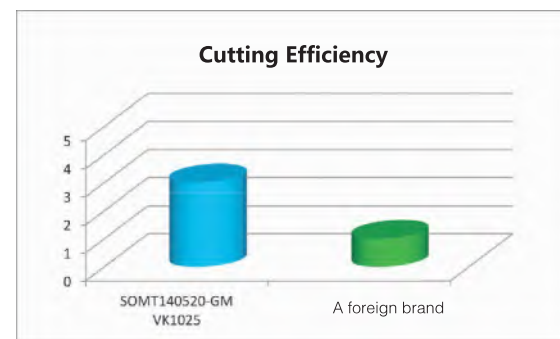

### Recommendation of Milling Grade

ISO		CVD			PVD		
K Cast Iron	01						
	10	VK3020			VK1015	VK1825	
	20						VK1525
	30		VK3040				
	40						
P Steel	01						
	10				VK1015		
	20					VK1825	
	30						VK1025
	40						
M Stainless Steel	01						
	10				VK1820		
	20					VK1824	VK1825
	30						VK1828
	40						VK1525
S Heat Resistant Alloy	01						
	10				VR1610		
	20					VR1525	
	30						
	40						VR1029































## Recommendation of Inserts and Chip Breakers







Should Milling Inserts						
	APMT-XR	APMT-GM	APMT-M2	APMT-H2	ADMT-JT	TPKT
Length	11/16	11/16	11/16	11/16	11/16	04/09
Page	B-16	B-16	B-17	B-17	B-18	B-19
Double-side Should Milling Inserts						
	ANMX	ANKT-M	LNGU-GM	WNMU-GM	XNEX-GL/GM	
Length	11/15	04/06/09/11	11	05/08	08	
Page	B-20	B-21	B-22	B-22	B-23	
Profile Milling Inserts						
	RPMW	RPMT-JM	RPMT-GM	RDKT	RPMT-XR	RPMT
Length	08/10/12	08/10/12/16	08/10/12	08/20	08/10/12	12
Page	B-24	B-24	B-25	B-26	B-27	B-28
Single-side High Feed Milling Inserts						
	EPNW-GH	LPGT-GM	SDMT-GM	SDMT-GH	SOMT-GM	SOMT-GH
Length	06	01	12/15	06/15	10	14
Page	B-29	B-29	B-30	B-30	B-31	B-31
Double-side High Feed Milling Inserts				45° Face Milling Inserts		
	LNMU-GM	LOGU-GM	BLMP-GM		SEMT-GM	SEER-GM
Length	03	03	04-11	Length	12	12/15
Page	B-32	B-32	B-33	Page	B-38	B-38



Super Alloy Titanium Alloy					
	RPHX-DF	RPHX-DM	APMT-DF	SDMT-DM	LNMU-MS
Length	10/12	10/12	11/16	06/09	03
Page	B-35	B-35	B-36	B-36	B-37
Double-side Cost-effective Face Milling Inserts					
	SNMU-GM	SNMX-GM	SNGX-GF	PNCU-GM	HNMG-R
Length	13	12/16	09	09	09
Page	B-39	B-40	B-40	B-41	B-42
Double-side Cost-effective Face Milling Inserts					
	HNMG-M	XNMU-MM	XNMU-GR	ONHU-AR	ONHU-AF
Length	09	07	07/09	05	05
Page	B-42	B-43	B-43	B-44	B-44
Double-side Cost-effective Face Milling Inserts		Helix Milling Inserts			
	ONMU-GM		APKT-PM	SP-KM	SP-PM
Length	09	Length	15	12	12
Page	B-45	Page	B-46	B-46	B-46

Helical Milling Inserts			
	CNHX	LNKT	LNKX
Length	16	16	12
Page	B-47	B-47	B-48



## Milling Insert Code Key

 A	 B	 C	B	Y	N		N	N	N	
 D	 E	 H	H	Y	Single		R	N	Single	
 K	 L	 M	C	Y	N		F	N	Double	
 O	 P	 R	J	Y	Double		A	Y	N	
 S	 T	 T	W	Y	N		M	Y	Single	
 V	 W	Others	T	Y	Single		G	Y	Double	
			Q	Y	N		X	---	---	Special Type
			U	Y	Double					
1. Shape			4. Chip Breaker and Hole							
Code			Center Hole	Chip Breaker	Insert Profile	Code	Center Hole	Chip Breaker	Insert Profile	

32.00			32						
31.75			31						
25.40			25	25					
25.00	25	25	25						
20.00			20						
19.05	19		19	19	33				
16.00		19	16						
15.875	16		15	16	27				
12.70	12	15	12	12	22	22	08		
12.00			12						
10.00			10						
9.525	09	11	09	09	16	16	06		
8.00			08						
6.35	06	07			11	11			
6.00			06						
5.56					09				
5.50			05						
3.97					06				
m								Insert Shape	
5. Cutting Edge Length									



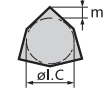
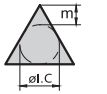

12	12.70
10	11.11
T9	9.72
09	9.52
07	7.94
T6	6.75
06	6.35
05	5.56
T4	4.96
04	4.76
T3	3.97
03	3.18
T2	2.78
02	2.38
T1	1.98
01	1.59
T0	0.99
00	0.79
Code	Thickness(mm)
	
6. Thickness	

**A P M T**

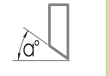
2. Clearance Angle				3. Tolerance										
Code	Clearance Angle	Code	Clearance Angle											
A	3°	B	5°	Code	m (mm)	d = I.C	S (mm)	Inscribed Circle	Regular Triangle	Square	80° Rhombus	55° Rhombus	35° Rhombus	
C	7°	D	15°	A	±0.005	±0.025	±0.025	6.35	±0.08	±0.08	±0.08	±0.11	±0.16	---
E	20°	F	25°	F	±0.005	±0.013	±0.025	9.525	±0.08	±0.08	±0.08	±0.11	±0.16	---
G	30°	N	0°	C	±0.013	±0.025	±0.025	12.7	±0.13	±0.13	±0.13	±0.15	---	---
P	11°	o	Others	H	±0.013	±0.013	±0.025	15.875	±0.15	±0.15	±0.15	±0.18	---	---
				E	±0.025	±0.025	±0.025	19.05	±0.15	±0.15	±0.15	±0.18	---	---
				G	±0.025	±0.025	±0.13	25.4	---	±0.18	---	---	---	---
				J	±0.005	±0.05±0.13	±0.025	♦ Tolerance of Inscribed Circle(mm)						
				K	±0.013	±0.05±0.13	±0.025	Inscribed Circle	Regular Triangle	Square	80° Rhombus	55° Rhombus	35° Rhombus	
				L	±0.025	±0.05±0.13	±0.025	6.35	±0.05	±0.05	±0.05	±0.05	±0.05	---
				M	±0.08±0.18	±0.05±0.13	±0.13	9.525	±0.05	±0.05	±0.05	±0.05	±0.05	±0.05
				N	±0.08±0.18	±0.05±0.13	±0.025	12.7	±0.08	±0.08	±0.08	±0.08	---	±0.08
				U	±0.13±0.38	±0.08±0.25	±0.13	15.875	±0.10	±0.10	±0.10	±0.10	---	±0.10
								19.05	±0.10	±0.10	±0.10	±0.10	---	±0.10
								25.4	---	±0.13	---	---	---	±0.13

**16 04 PD E R - GM**

7. Approach Angle/Relief Angle			
			
A	45°	A	3°
D	60°	B	5°
E	75°	C	7°
F	85°	D	15°
P	90°	E	20°
Z	other	F	25°
		G	30°
		N	0°
		P	11°
		Z	other

8. Cutting Edge Code			
			
F	0-5°	0-0.10	k (or no code)
E	1-10°	1-0.15	
T	2-15°	2-0.20	P
S	3-20°	3-0.25	W
	4-25°	4-0.30	Q
	5-30°	5-0.35	
	1-10°	6-0.40	
	1-10°	7-0.45	

10. Chip Breaker	
9. Cutting Direction Code	
R	Right
L	Left
N	Neutral

## Shoulder Milling Inserts

### AP□□ Inserts

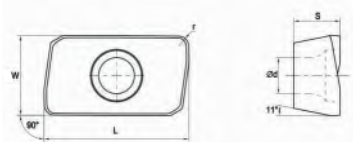

Length	Size(mm)			
	L	W	S	r
11	11.35	6.2	3.5	0.8
16	17.35	9.3	5.26	0.8

Shape	Type	ap (mm)	fz (mm/z)	CVD		PVD											
				VK3020	VK3040	VK1015	VK1025	VK1824	VK1825	VK1525	VK1828	VR1010	VR1520	VR1525	VR1029		
	APMT1135PDER-XR	2.50-7.50	0.05-0.25			○	●	○	●	●	○						
	APMT1605PDER-XR	3.50-10.00	0.07-0.50			○	●	○	●	●	○						

Note: ● The Recommended Grade ready to stock

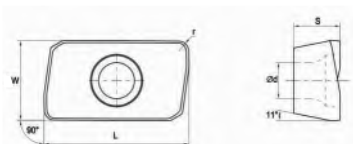

Length	Size(mm)			
	L	W	S	r
11	11.35	6.2	3.5	0.8
16	17.35	9.3	5.26	0.8

Shape	Type	ap (mm)	fz (mm/z)	CVD		PVD											
				VK3020	VK3040	VK1015	VK1025	VK1824	VK1825	VK1525	VK1828	VR1010	VR1520	VR1525	VR1029		
	APMT1135PDER-GM	2.50-7.50	0.05-0.25			○	●	○	●	●	○						
	APMT160408PDER-GM	3.50-10.00	0.07-0.50			○	●	○	●	●	○						

Note: ● The Recommended Grade ready to stock

### AP□□ Inserts

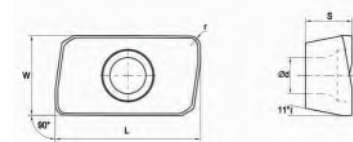

Length	Size(mm)			
	L	W	S	r
11	11.35	6.2	3.5	0.8
16	17.35	9.2	4.76	0.8

Shape	Type	ap (mm)	fz (mm/z)	CVD		PVD											
				VK3020	VK3040	VK1015	VK1025	VK1824	VK1825	VK1525	VK1828	VR1010	VR1520	VR1525	VR1029		
	APMT1135PDER-M2	2.50-7.50	0.05-0.25			○	●	○	●	●	○						
	APMT160408PDER-M2	3.50-10.00	0.07-0.30			○	●	○	●	●	○						

Note: ● The Recommended Grade ready to stock

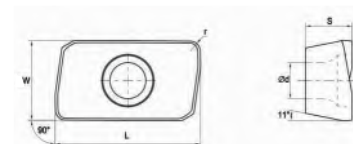

Length	Size(mm)			
	L	W	S	r
11	11.35	6.2	3.5	0.8
16	17.35	9.2	4.76	0.8

Shape	Type	ap (mm)	fz (mm/z)	CVD		PVD											
				VK3020	VK3040	VK1015	VK1025	VK1824	VK1825	VK1525	VK1828	VR1010	VR1520	VR1525	VR1029		
	APMT1135PDER-H2	2.50-7.50	0.05-0.25			○	●	○	●	●	○						
	APMT160408PDER-H2	3.50-10.00	0.07-0.30			○	●	○	●	●	○						

Note: ● The Recommended Grade ready to stock

## Shoulder Milling Inserts

### AD□□Inserts

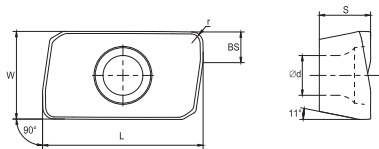

Length	Size(mm)				
	L	W	S	BS	r
11	11	6.7	3.8	1.4-2.1	0.2-1.2

Shape	Type	ap (mm)	fz (mm/z)	CVD		PVD											
				VK3020	VK3040	VK1015	VK1025	VK1824	VK1825	VK1525	VK1828	VR1010	VR1520	VR1525	VR1029		
	ADMT11T302ER-JT	2.0-6.0	0.06-0.15			○	●	○	●	●	○						
	ADMT11T304ER-JT	2.2-8.0	0.08-0.15			○	●	○	●	●	○						
	ADMT11T308ER-JT	2.5-10.0	0.10-0.18			○	●	○	●	●	○						
	ADMT11T312ER-JT	2.8-10.0	0.08-0.20			○	●	○	●	●	○						
	ADMT170408ER-JT	3.5-10.0	0.08-0.25			○	●	○	●	●	○						

Note: ● The Recommended Grade ready to stock

### TP□□Inserts

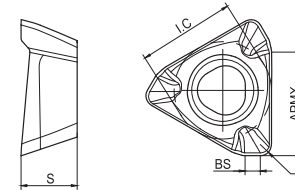

Length	Size(mm)				
	IC	S	APMX	BS	r
4	3.9	2.1	3.5	0.5-0.7	0.2-0.4
6	5.3	2.8	4.7	0.6-1.2	0.2-0.8
10	6.9	4	7	0.5-1.3	0.4-1.6
15	10.7	5	11	0.5-2.0	0.4-2.4
19	13.5	6	15	0.5-2.0	0.4-3.2

Shape	Type	ap (mm)	fz (mm/z)	CVD		PVD											
				VK3020	VK3040	VK1015	VK1025	VK1824	VK1825	VK1525	VK1828	VR1010	VR1520	VR1525	VR1029		
	TPKT040202R-M	0.50-3.00	0.04-0.08			○	●	○	●	●	○						
	TPKT040204R-M	0.50-3.00	0.04-0.08			○	●	○	●	●	○						
	TPKT060302R-M	1.00-4.00	0.04-0.10			○	●	○	●	●	○						
	TPKT060304R-M	1.00-4.00	0.04-0.10			○	●	○	●	●	○						
	TPKT060308R-M	1.00-4.00	0.04-0.10			○	●	○	●	●	○						
	TPKT100404R-M	2.00-6.00	0.05-0.12			○	●	○	●	●	○						
	TPKT100408R-M	2.00-6.00	0.05-0.12			○	●	○	●	●	○						
	TPKT100416R-M	2.00-6.00	0.05-0.12			○	●	○	●	●	○						
	TPKT150508R-M	3.00-9.00	0.07-0.17			○	●	○	●	●	○						
	TPKT150516R-M	3.00-9.00	0.07-0.17			○	●	○	●	●	○						
	TPKT150524R-M	3.00-12.00	0.07-0.17			○	●	○	●	●	○						
	TPKT190608R-M	4.50-12.00	0.09-0.22			○	●	○	●	●	○						
	TPKT190616R-M	4.50-12.00	0.09-0.22			○	●	○	●	●	○						
	TPKT190624R-M	4.50-12.00	0.09-0.22			○	●	○	●	●	○						
	TPKT190632R-M	4.50-12.00	0.09-0.22			○	●	○	●	●	○						

Note: ● The Recommended Grade ready to stock

## Shoulder Milling Inserts

### AN□□Inserts

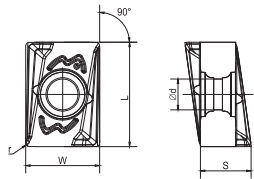

Length	Size(mm)					
	L	W	S	APMX	BS	r
11	11.85	8.4	5.7			0.4-0.8
15	15.430	11	7.3			0.8-1.6

Shape	Type	ap (mm)	fz (mm/z)	CVD		PVD											
				VK3020	VK3040	VK1015	VK1025	VK1824	VK1825	VK1525	VK1828	VR1010	VR1520	VR1525	VR1029		
	ANMX110504PNR	2.00-9.00	0.10-0.20			○	●	○	●	●	○						
	ANMX110508PNR	3.00-9.00	0.10-0.20			○	●	○	●	●	○						
	ANMX150608PNR	4.50-12.00	0.10-0.20			○	●	○	●	●	○						
	ANMX150616PNR	5.00-12.00	0.10-0.20			○	●	○	●	●	○						

Note: ● The Recommended Grade ready to stock

### AN□□Inserts

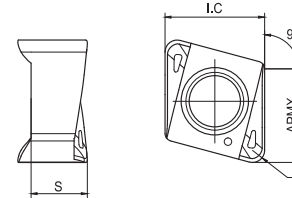

Length	Size(mm)				
	IC	S	APMX	BS	r
4	4	3.1	3.5	-	0.2-0.8
6	6.6	4.2-5.0	5.8-6.2	0.6-1.0	0.4-2.0
9	8.6	5.7-6.3	8	0.8-1.2	0.4-1.6
11	10.7	8.1	10.5	1	0.8

Shape	Type	ap (mm)	fz (mm/z)	CVD		PVD											
				VK3020	VK3040	VK1015	VK1025	VK1824	VK1825	VK1525	VK1828	VR1010	VR1520	VR1525	VR1029		
	ANKT040202R-M	0.50-3.00	0.04-0.08			○	●	○	●	●	○						
	ANKT040204R-M	1.00-3.00	0.06-0.12			○	●	○	●	●	○						
	ANKT040208R-M	1.00-3.00	0.06-0.12			○	●	○	●	●	○						
	ANKT060304R-M	0.50-5.00	0.07-0.15			○	●	○	●	●	○						
	ANKT060308R-M	1.00-5.00	0.07-0.15			○	●	○	●	●	○						
	ANKT060312R-M	1.00-5.00	0.07-0.15			○	●	○	●	●	○						
	ANKT060316R-M	2.00-4.50	0.07-0.15			○	●	○	●	●	○						
	ANKT060320R-M	2.00-4.50	0.07-0.15			○	●	○	●	●	○						
	ANKT090408R-M	2.50-7.00	0.07-0.15			○	●	○	●	●	○						
	ANKT090416R-M	2.50-7.00	0.07-0.15			○	●	○	●	●	○						
ANKT110608R-M	3.50-10.0	0.09-0.15			○	●	○	●	●	○							

Note: ● The Recommended Grade ready to stock

## Shoulder Milling Inserts

### LN□□ Inserts

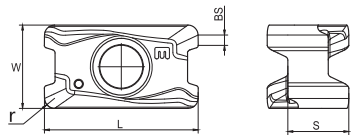

Length	Size(mm)				
	L	S	W	BS	r
11	12.16	4.83	6.6	1.4	0.4-1.2

Shape	Type	ap (mm)	fz (mm/z)	CVD		PVD												
				VK3020	VK3040	VK1015	VK1025	VK1824	VK1825	VK1525	VK1828	VR1010	VR1520	VR1525	VR1029			
	LNGU110404ERGE-GM	max=10	0.50-1.50			○	●	○	●	●	○							
	LNGU110408ERGE-GM	max=10	0.50-1.50			○	●	○	●	●	○							
	LNGU110412ERGE-GM	max=10	0.50-1.50			○	●	○	●	●	○							

Note: ●Recommended grade ready to stock

### XN□□ Inserts

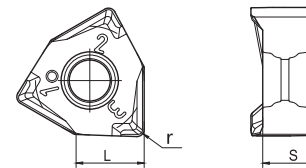

Length	Size(mm)	
	L	S
08	7.5	6.45

Shape	Type	ap (mm)	fz (mm/z)	CVD		PVD												
				VK3020	VK3040	VK1015	VK1025	VK1824	VK1825	VK1525	VK1828	VR1010	VR1520	VR1525	VR1029			
	XNEX080608TR-GL	0.80-8.00	0.10-0.30			○	●	○	●	●	○							
	XNEX080612TR-GL	0.80-8.00	0.10-0.30			○	●	○	●	●	○							
	XNEX080608TR-GM	0.80-8.00	0.10-0.30			○	●	○	●	●	○							

Note: ●Recommended grade ready to stock

### WN□□ Inserts

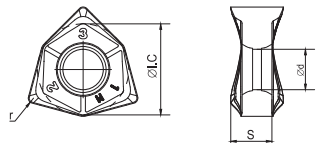

Length	Size(mm)		
	S	d	r
5	4.2	3.4	0.8
8	6.65	6.2	0.8

Shape	Type	ap (mm)	fz (mm/z)	CVD		PVD												
				VK3020	VK3040	VK1015	VK1025	VK1824	VK1825	VK1525	VK1828	VR1010	VR1520	VR1525	VR1029			
	WNMU050408EN-GM	0.50-5.00	0.10-0.30			○	●	○	●	●	○							
	WNMU080608EN-GM	0.80-8.00	0.10-0.30			○	●	○	●	●	○							

Note: ●Recommended grade ready to stock

## Shoulder Milling Inserts

### RP□□ Inserts

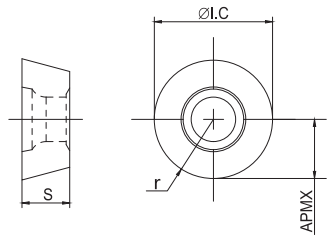

Length	Size(mm)			
	r	I.C	S	APMX
8	4	8	2.78	4
10	5	10	3.18	5
12	6	12	4.76	6

Shape	Type	ap (mm)	fz (mm/z)	CVD		PVD											
				VK3020	VK3040	VK1015	VK1025	VK1824	VK1825	VK1525	VK1828	VR1010	VR1520	VR1525	VR1029		
	RPMW08T2MO	1.00–3.00	0.05–0.25			○	●	○	●	●	○						
	RPMW1003MO	1.50–4.00	0.05–0.30			○	●	○	●	●	○						
	RPMW1204MO	1.50–5.00	0.05–0.35			○	●	○	●	●	○						

Note: ● The Recommended Grade ready to stock

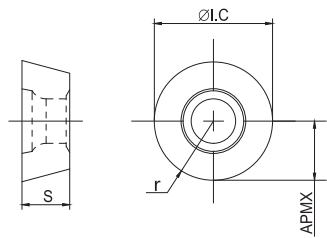

Length	Size(mm)			
	r	I.C	S	APMX
8	4	8	2.78	4
10	5	10	3.97	5
12	6	12	4.76	6
16	8	16	6.35	8

Shape	Type	ap (mm)	fz (mm/z)	CVD		PVD											
				VK3020	VK3040	VK1015	VK1025	VK1824	VK1825	VK1525	VK1828	VR1010	VR1520	VR1525	VR1029		
	RPMT08T2MOE–JM	1.00–1.30	0.05–0.25			○	●	○	●	●	○						
	RPMT10T3MOE–JM	1.50–4.00	0.05–0.30			○	●	○	●	●	○						
	RPMT1204MOE–JM	1.50–5.00	0.05–0.35			○	●	○	●	●	○						
	RPMT1606MOE–JM	2.00–6.50	0.10–0.40			○	●	○	●	●	○						

Note: ● The Recommended Grade ready to stock

### RP□□ Inserts

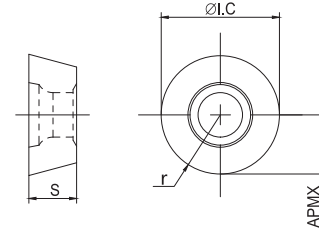

Length	Size(mm)			
	r	I.C	S	APMX
8	4	8	2.78	4
10	5	10	3.18	5
12	6	12	4.76	6

Shape	Type	ap (mm)	fz (mm/z)	CVD		PVD											
				VK3020	VK3040	VK1015	VK1025	VK1824	VK1825	VK1525	VK1828	VR1010	VR1520	VR1525	VR1029		
	RPMT08T2MO–GM	1.50–4.00	0.10–0.30			○	●	○	●	●	○						
	RPMT10T3MO–GM	1.80–5.00	0.10–0.50			○	●	○	●	●	○						
	RPMT1204MO–GM	2.00–6.50	0.10–0.50			○	●	○	●	●	○						

Note: ● The Recommended Grade ready to stock

## Profile Milling Inserts

### RD□□ Inserts

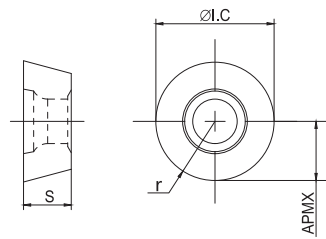

Length	Size(mm)			
	r	I.C	S	APMX
8	4	8	3.18	4
10	5	10	3.97	5
12	6	12	4.76	6
16	8	16	5.56	8
20	10	20	6.35	10

### RP□□ Inserts

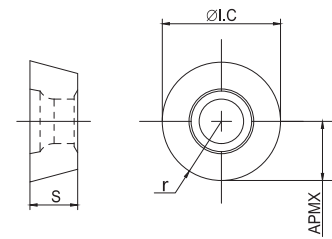

Length	Size(mm)			
	r	I.C	S	APMX
8	4	8	2.78	4
10	5	10	3.97	5
12	6	12	4.76	6

Shape	Type	ap (mm)	fz (mm/z)	CVD		PVD											
				VK3020	VK3040	VK1015	VK1025	VK1824	VK1825	VK1525	VK1828	VR1010	VR1520	VR1525	VR1029		
	RDKT0803MO	1.00-3.00	0.05-0.25			○	●	○	●	●	○						
	RDKT10T3MO	1.50-4.00	0.05-0.30			○	●	○	●	●	○						
	RDKT1204MO	1.50-5.00	0.05-0.35			○	●	○	●	●	○						
	RDKT1604MO	2.00-6.50	0.10-0.40			○	●	○	●	●	○						
	RDKT1605MO	2.00-6.50	0.10-0.40			○	●	○	●	●	○						
	RDKT1606MO	2.00-6.50	0.10-0.40			○	●	○	●	●	○						
	RDKT2006MO	3.00-8.00	0.10-0.40			○	●	○	●	●	○						

Note: ● The Recommended Grade ready to stock

Shape	Type	ap (mm)	fz (mm/z)	CVD		PVD											
				VK3020	VK3040	VK1015	VK1025	VK1824	VK1825	VK1525	VK1828	VR1010	VR1520	VR1525	VR1029		
	RPMT0803-XR	1.00-1.30	0.05-0.25			○	●	○	●	●	○						
	RPMT10T3-XR	1.50-4.00	0.05-0.30			○	●	○	●	●	○						
	RPMT1204-XR	1.50-5.00	0.05-0.35			○	●	○	●	●	○						

Note: ● The Recommended Grade ready to stock

## Profile Milling Inserts

### RP□□ Inserts

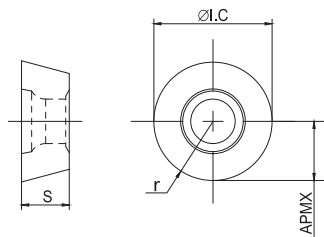

Length	Size(mm)			
	r	I.C	S	APMX
8	4	8	2.78	4
10	5	10	3.97	5
12	6	12	4.76	6

Shape	Type	ap (mm)	fz (mm/z)	CVD		PVD													
				VK3020	VK3040	VK1015	VK1025	VK1824	VK1825	VK1525	VK1828	VR1010	VR1520	VR1525	VR1029				
	RPMT08T2MO	1.5-4.0	0.1-0.3			○	●	○	●	●	○								
	RPMT10T3MO	1.8-5.0	0.1-0.5			○	●	○	●	●	○								
	RPMT1204MO	2-6.5	0.1-0.5			○	●	○	●	●	○								

Note: ● The Recommended Grade ready to stock

## High Feed Milling Inserts

### EP□□ Inserts

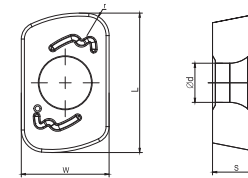

Size(mm)				
W	S	d	L	r
6.28	3.18	2.8	9.79	1.6

Shape	Type	ap (mm)	fz (mm/z)	CVD		PVD													
				VK3020	VK3040	VK1015	VK1025	VK1824	VK1825	VK1525	VK1828	VR1010	VR1520	VR1525	VR1029				
	EPNW0603TN-GH	max=1.5	0.15-0.50			○	●	○	●	●	○								

### LP□□ Inserts

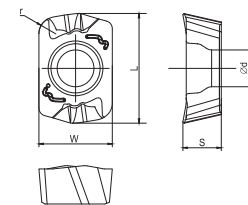

Size(mm)				
W	S	d	L	r
4.19	2.19	2.1	6.26	1

Shape	Type	ap (mm)	fz (mm/z)	CVD		PVD													
				VK3020	VK3040	VK1015	VK1025	VK1824	VK1825	VK1525	VK1828	VR1010	VR1520	VR1525	VR1029				
	LPGT010210ER-GM	max=1	0.50-1.50			○	●	○	●	●	○								

Note: ● The Recommended Grade ready to stock

## High Feed Milling Inserts

### SD□□ Inserts

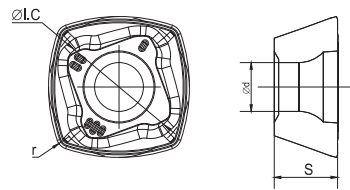

Length	Size(mm)		
	I.C	S	r
12	12.7	5.56	1.2
15	15.875	5.56	1.2

Shape	Type	ap (mm)	fz (mm/z)	CVD		PVD											
				VK3020	VK3040	VK1015	VK1025	VK1824	VK1825	VK1525	VK1828	VR1010	VR1520	VR1525	VR1029		
	SDMT120512-GM	0.50-2.00	0.60-1.20			○	●	○	●	●	○						
	SDMT150512-GM	0.80-3.00	0.60-1.20			○	●	○	●	●	○						
						○	●	○	●	●	○						
						○	●	○	●	●	○						

Note: ● The Recommended Grade ready to stock

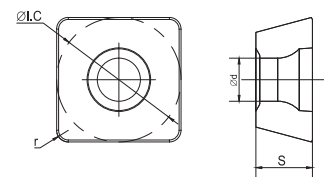

Length	Size(mm)		
	I.C	S	r
6	6.35	2.58	0.8
9	9.525	3.97	1.2
12	12.7	4.76	1.2
15	15.875	5.56	2

Shape	Type	ap (mm)	fz (mm/z)	CVD		PVD											
				VK3020	VK3040	VK1015	VK1025	VK1824	VK1825	VK1525	VK1828	VR1010	VR1520	VR1525	VR1029		
	SDMT06T208-GH	0.50-1.20	0.50-1.00			○	●	○	●	●	○						
	SDMT09T312-GH	0.50-1.80	0.50-1.00			○	●	○	●	●	○						
	SDMT120412-GH	0.50-2.00	0.60-1.20			○	●	○	●	●	○						
	SDMT150520-GH	0.80-3.00	0.60-1.20			○	●	○	●	●	○						

Note: ● The Recommended Grade ready to stock

### SO□□ Inserts

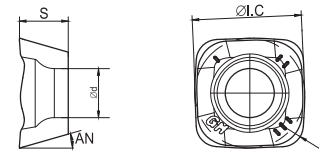

Length	Size(mm)				
	I.C	S	d	r	AN(°)
10	10.3	4.58	4.6	2	16

Shape	Type	ap (mm)	fz (mm/z)	CVD		PVD											
				VK3020	VK3040	VK1015	VK1025	VK1824	VK1825	VK1525	VK1828	VR1010	VR1520	VR1525	VR1029		
	SOMT100420ER-GM	0.10-1.20	0.20-2.00			○	●	○	●	●	○						

Note: ● The Recommended Grade ready to stock

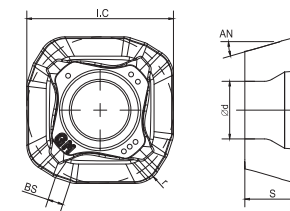

Length	Size(mm)					
	I.C	S	d	BS	r	AN(°)
14	14.76	5.56	5.8	1.6	2	16

Shape	Type	ap (mm)	fz (mm/z)	CVD		PVD											
				VK3020	VK3040	VK1015	VK1025	VK1824	VK1825	VK1525	VK1828	VR1010	VR1520	VR1525	VR1029		
	SOMT140520ER-GH	0.50-2.00	0.42-2.00			○	●	○	●	●	○						

Note: ● The Recommended Grade ready to stock

## High Feed Milling Inserts

### LN□□ Inserts

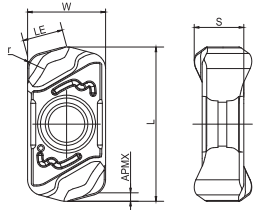

Length	Size(mm)				
	r	APMX	L	I.C	S
3	1.2	1	3.2	6	4.3

Shape	Type	ap (mm)	fz (mm/z)	CVD		PVD												
				VK3020	VK3040	VK1015	VK1025	VK1824	VK1825	VK1525	VK1828	VR1010	VR1520	VR1525	VR1029			
	LNMU0303ZER-GM	0.20-2.00	0.50-1.30			○	●	○	●	●	○							

Note: ● The Recommended Grade ready to stock

### LO□□ Inserts

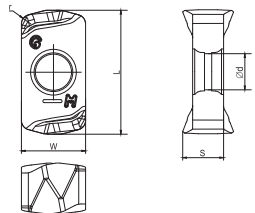

Length	Size(mm)				
	W	S	d	L	r
3	6.2	3.96	3.45	11.9	1

Shape	Type	ap (mm)	fz (mm/z)	CVD		PVD												
				VK3020	VK3040	VK1015	VK1025	VK1824	VK1825	VK1525	VK1828	VR1010	VR1520	VR1525	VR1029			
	LOGU030310ER-GM	max=1	0.50-1.50			○	●	○	●	●	○							

Note: ● The Recommended Grade ready to stock

### BL□□ Inserts

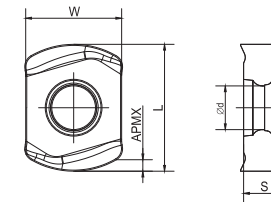

Length	Size(mm)			
	L	W	S	APMX
4	6	4.2	2.5	0.5
6	9	6.39	3.73	1
9	11.9	9.18	4.8	1.5
11	14.6	11.2	6.5	2

Shape	Type	ap (mm)	fz (mm/z)	CVD		PVD												
				VK3020	VK3040	VK1015	VK1025	VK1824	VK1825	VK1525	VK1828	VR1010	VR1520	VR1525	VR1029			
	BLMP0402R-GM	0.10-0.50	0.20-1.50			○	●	○	●	●	○							
	BLMP0603R-GM	0.10-1.00	0.30-2.50			○	●	○	●	●	○							
	BLMP0904R-GM	0.10-1.50	0.30-3.50			○	●	○	●	●	○							
	BLMP1105R-GM	0.30-2.00	0.30-4.00			○	●	○	●	●	○							

Note: ● The Recommended Grade ready to stock



## Heat Resistant Alloys / Titanium Alloys

### AP□□ Inserts

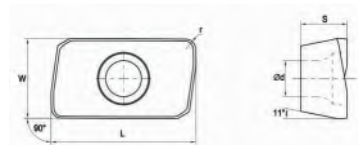

Length	Size(mm)			
	L	W	S	r
11	11.4	6.2	3.5	0.8
16	17.25	9.2	4.76	0.8、3

Shape	Type	ap (mm)	fz (mm/z)	CVD				PVD							
				VK3115	VK4213	VK4223	VK4235	VK1025	VK1525	VK1528	VK1824	VR1520	VR1610	VR1525	VR1632
	APMT1135PDER-DF	2.5-7.5	0.05-0.25										●	●	○
	APMT160408PDER-DF	3.5-10	0.07-0.5										●	●	○
	APMT160430PDER-DF	5.0-10	0.2-0.5										●	●	○
	APMT1135PDER-DM	2.5-7.5	0.05-0.35										●	●	○
	APMT160408PDER-DM	3.5-10	0.2-0.7										●	●	○

Note: ● The Recommended Grade ready to stock

### SD□□ Inserts

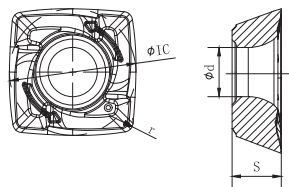

Length	Size(mm)		
	I.C	S	r
6	6.35	2.78	0.5
9	9	3.5	0.7

Shape	Type	ap (mm)	fz (mm/z)	CVD				PVD							
				VK3115	VK4213	VK4223	VK4235	VK1025	VK1525	VK1528	VK1824	VR1520	VR1610	VR1525	VR1632
	SDMT06T205-DM		0.1-1.0										●	●	○
	SDMT09T307-DM		0.2-1.2										●	●	○

Note: ● The Recommended Grade ready to stock

### LN□□ Inserts

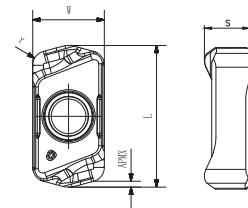

Length	Size(mm)				
	W	S	APMX	L	r
3	6	3.75	1	11.8	1.2

Shape	Type	ap (mm)	fz (mm/z)	CVD				PVD									
				VK3115	VK4213	VK4223	VK4235	VK1025	VK1525	VK1528	VK1824	VR1520	VR1610	VR1525	VR1632	VR1029	
	LNMU0303ZER-MS	0.2-2.0	0.5-1.3												●	●	○

Note: ● The Recommended Grade ready to stock

## 45° Face Milling Inserts

### SE□□ Inserts

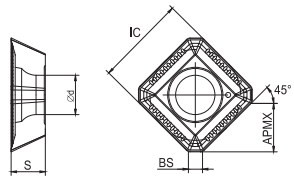

Length	Size(mm)			
	BS	APMX	I.C	S
12	1.5	6.5	12.7	4.76

Shape	Type	ap (mm)	fz (mm/z)	CVD		PVD												
				VK3020	VK3040	VK1015	VK1025	VK1824	VK1825	VK1525	VK1828	VR1010	VR1520	VR1525	VR1029			
	SEMT1204AFTN-GM	3.00-8.50	0.09-0.16			○	●	○	●	●	○							

Note: ● The Recommended Grade ready to stock

### SE□□ Inserts

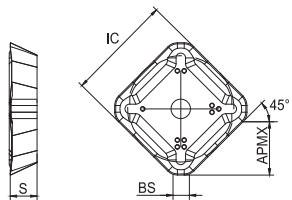

Length	Size(mm)			
	BS	APMX	I.C	S
12	1.5	6.5	12.7	3.19
15	2	8.5	15.875	4.76

Shape	Type	ap (mm)	fz (mm/z)	CVD		PVD												
				VK3020	VK3040	VK1015	VK1025	VK1824	VK1825	VK1525	VK1828	VR1010	VR1520	VR1525	VR1029			
	SEER1203-GM	1.50-6.00	0.10-0.25			○	●	○	●	●	○							
	SEER1504-GM	1.50-8.00	0.10-0.25			○	●	○	●	●	○							

Note: ● The Recommended Grade ready to stock

## 88° Approaching Angle Cost-effective Face Milling Inserts

### SN□□ Inserts

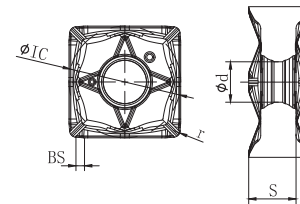

Length	Size(mm)			
	I.C	S	BS	r
13	13	5.5	1	0.8

Shape	Type	ap (mm)	fz (mm/z)	CVD		PVD												
				VK3020	VK3040	VK1015	VK1025	VK1824	VK1825	VK1525	VK1828	VR1010	VR1520	VR1525	VR1029			
	SNMU130508EN-GM	1.0-5.0	0.1-0.25			○	●	○	●	●	○							

Note: ● The Recommended Grade ready to stock

## Cost-effective Face Milling Inserts

### SN□□ Inserts

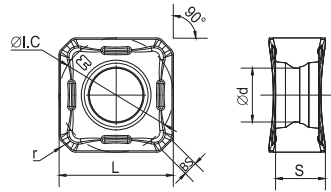

Length	Size(mm)		
	I.C	S	BS
12	12.7	6.4	1.5
16	16	7.7	1.8

Shape	Type	ap (mm)	fz (mm/z)	CVD		PVD												
				VK3020	VK3040	VK1015	VK1025	VK1824	VK1825	VK1525	VK1828	VR1010	VR1520	VR1525	VR1029			
	SNMX1205ANN-GM	1.00-6.00	0.15-0.50			○	●	○	●	●	○							
	SNMX1606ANN-GM	1.00-6.00	0.15-0.50			○	●	○	●	●	○							

Note: ● The Recommended Grade ready to stock

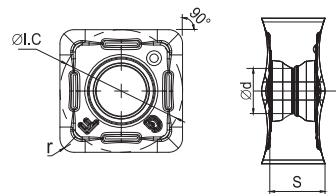

Length	Size(mm)		
	I.C	S	r
9	9.525	5.5	0.8-1.1

Shape	Type	ap (mm)	fz (mm/z)	CVD		PVD												
				VK3020	VK3040	VK1015	VK1025	VK1824	VK1825	VK1525	VK1828	VR1010	VR1520	VR1525	VR1029			
	SNGX090408-GF	2.50-7.50	0.08-0.15			○	●	○	●	●	○							
	SNGX090411-GF	2.50-7.50	0.08-0.15			○	●	○	●	●	○							

Note: ● The Recommended Grade ready to stock

### PN□□ Inserts

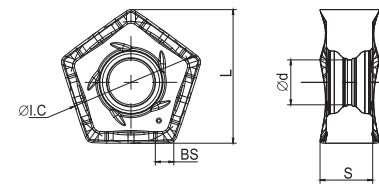

Length	Size(mm)				
	L	S	d	BCH	BS
09	12.2	13.4	5.35	4.5	2

Shape	Type	ap (mm)	fz (mm/z)	CVD		PVD												
				VK3020	VK3040	VK1015	VK1025	VK1824	VK1825	VK1525	VK1828	VR1010	VR1520	VR1525	VR1029			
	PNCU0905GNEN-GM	0.50-3.00	0.20-0.60			○	●	○	●	●	○							

Note: ● The Recommended Grade ready to stock

## Cost-effective Face Milling Inserts

### HN□□ Inserts

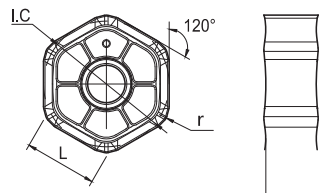

Length	Size(mm)		
	I.C	S	r
9	16.5	6.35	1.0

Shape	Type	ap (mm)	fz (mm/z)	CVD		PVD												
				VK3020	VK3040	VK1015	VK1025	VK1824	VK1825	VK1525	VK1828	VR1010	VR1520	VR1525	VR1029			
	HNMG0907ANSN-R	1.50-4.00	0.20-0.70			○	●	○	●	●	○							

Note: ● The Recommended Grade ready to stock

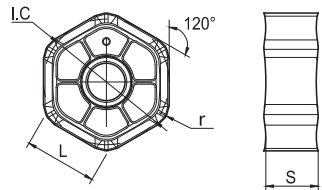

Length	Size(mm)		
	I.C	S	r
9	16.5	6.35	1.0

Shape	Type	ap (mm)	fz (mm/z)	CVD		PVD												
				VK3020	VK3040	VK1015	VK1025	VK1824	VK1825	VK1525	VK1828	VR1010	VR1520	VR1525	VR1029			
	HNMG0907ANSN-M	1.00-3.00	0.05-0.15			○	●	○	●	●	○							

Note: ● The Recommended Grade ready to stock

## Cost-effective Face Milling Inserts

### XN□□ Inserts

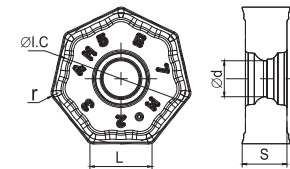

Length	Size(mm)			
	I.C	S	d	r
7	12	5.8	4	0.8

Shape	Type	ap (mm)	fz (mm/z)	CVD		PVD												
				VK3020	VK3040	VK1015	VK1025	VK1824	VK1825	VK1525	VK1828	VR1010	VR1520	VR1525	VR1029			
	XNMU070508-MM	0.2-3.0	0.05-0.2			○	●	○	●	●	○							

Note: ● The Recommended Grade ready to stock

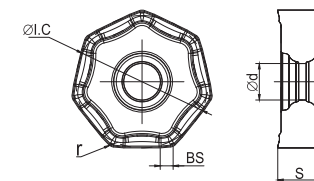

Length	Size(mm)				
	I.C	S	d	BS	r
9	19.05	5.9	5.5	1.5	1.2

Shape	Type	ap (mm)	fz (mm/z)	CVD		PVD												
				VK3020	VK3040	VK1015	VK1025	VK1824	VK1825	VK1525	VK1828	VR1010	VR1520	VR1525	VR1029			
	XNMU090612-GR	0.3-3.0	0.05-0.3			○	●	○	●	●	○							

Note: ● The Recommended Grade ready to stock

## Cost-effective Face Milling Inserts

### ON□□ Inserts

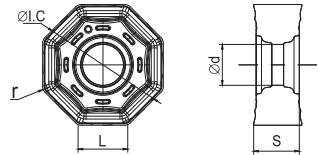

Length	Size(mm)		
	I.C	S	r
05	12.7	4.76	0.8

Shape	Type	ap (mm)	fz (mm/z)	CVD		PVD													
				VK3020	VK3040	VK1015	VK1025	VK1824	VK1825	VK1525	VK1828	VR1010	VR1520	VR1525	VR1029				
	ONHU050408-AR	0.8-3.5	0.2-0.35			○	●	○	●	●	○								

Note: ● The Recommended Grade ready to stock

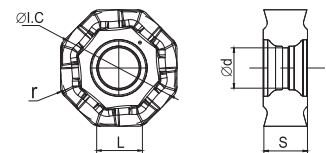

Length	Size(mm)		
	I.C	S	r
05	12.7	4.76	0.8

Shape	Type	ap (mm)	fz (mm/z)	CVD		PVD													
				VK3020	VK3040	VK1015	VK1025	VK1824	VK1825	VK1525	VK1828	VR1010	VR1520	VR1525	VR1029				
	ONHU050408-AF	0.5-2.5	0.1-0.25			○	●	○	●	●	○								

Note: ● The Recommended Grade ready to stock

## Cost-effective Face Milling Inserts

### ON□□ Inserts

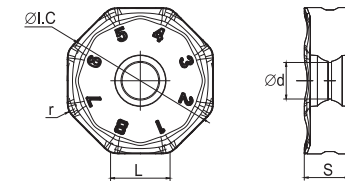

Length	Size(mm)		
	I.C	S	BS
09	22	5.8	0.45
09	22	5.8	2.11

Shape	Type	ap (mm)	fz (mm/z)	CVD		PVD													
				VK3020	VK3040	VK1015	VK1025	VK1824	VK1825	VK1525	VK1828	VR1010	VR1520	VR1525	VR1029				
	ONMU090520ANTN-GM	0.80-2.50	0.10-0.20			○	●	○	●	●	○								
	ONMU090520ANTN-GR	1.00-3.50	0.10-0.20			○	●	○	●	●	○								

Note: ● The Recommended Grade ready to stock

## Helix Milling Inserts

### AP□□ Inserts

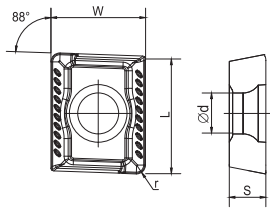

Length	Size(mm)				
	L	W	S	d	r
15	16.33	12.7	4.76	5.4	1.2

Shape	Type	ap (mm)	fz (mm/z)	CVD		PVD											
				VK3020	VK3040	VK1015	VK1025	VK1824	VK1825	VK1525	VK1828	VR1010	VR1520	VR1525	VR1029		
	APKT150412-PM	1.2-8	0.08-0.2			○	●	○	●	●	○						
	APKT150415-KM	1.2-8	0.08-0.2			○	●	○	●	●	○						

Note: ● The Recommended Grade ready to stock

### SP□□ Inserts

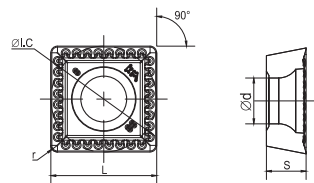

Length	Size(mm)				
	r	L	I.C	S	d
12	0.8	12.7	12.7	4.76	5.5

Shape	Type	ap (mm)	fz (mm/z)	CVD		PVD											
				VK3020	VK3040	VK1015	VK1025	VK1824	VK1825	VK1525	VK1828	VR1010	VR1520	VR1525	VR1029		
	SPMT120408-PM	1.00-6.00	0.06-0.15			○	●	○	●	●	○						
	SPMT120408-KM	1.00-6.00	0.06-0.15			○	●	○	●	●	○						

Note: ● The Recommended Grade ready to stock

## Helical Milling Inserts

### CN□□ Inserts

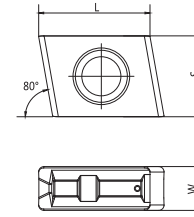

Type	Size(mm)		
	L	S	W
160608T	16	12	6.4

Shape	Type	ap (mm)	fz (mm/z)	CVD		PVD											
				VK3020	VK3040	VK1015	VK1025	VK1824	VK1825	VK1525	VK1828	VR1010	VR1520	VR1525	VR1029		
	CNHX160608T	1.20-5.50	0.20-0.60			○	●	○	●	●	○						

Note: ● The Recommended Grade ready to stock

### LN□□ Inserts

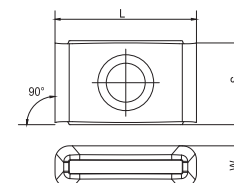

Type	Size(mm)		
	L	S	W
16090416	16	9.5	4.76

Shape	Type	ap (mm)	fz (mm/z)	CVD		PVD											
				VK3020	VK3040	VK1015	VK1025	VK1824	VK1825	VK1525	VK1828	VR1010	VR1520	VR1525	VR1029		
	LNKT16090416	1.60-12.00	0.15-0.50			○	●	○	●	●	○						

Note: ● The Recommended Grade ready to stock

# B Milling Inserts

## LN□□ Inserts

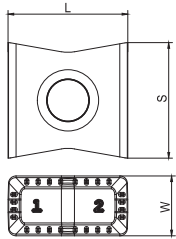

Type	Size(mm)		
	L	S	W
120608	12.7	12.25	6.35

Shape	Type	ap (mm)	fz (mm/z)	CVD		PVD											
				VK3020	VK3040	VK1015	VK1025	VK1824	VK1825	VK1525	VK1828	VR1010	VR1520	VR1525	VR1029		
	LNKX120608	2.00-7.00	0.10-0.20			○	●	○	●	●	○						

Note: ● The Recommended Grade ready to stock

## Drilling Inserts



# WEGAN

Milling Inserts

## WC□□ Inserts

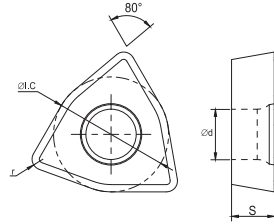

Shape	Type	Boring Range (mm)	Size					Application	Grade	
			L	øl.C	S	Φd	r		PVD	
									VK1025	VK1825
	WCMT030208-GM	16-20	3.8	5.56	2.38	2.8	0.8	Semi-finishing	●	●
	WCMT040208-GM	21-25	4.3	6.35	2.38	3.1	0.8		●	●
	WCMT050308-GM	26-30	5.4	7.94	3.18	3.2	0.8		●	●
	WCMT06T308-GM	31-41	6.5	9.525	3.97	3.7	0.8		●	●
	WCMT080412-GM	42-58	8.7	12.7	4.76	4.3	1.2		●	●
	WCMT030208-GF	16-20	3.8	5.56	2.38	2.8	0.8	Finishing	●	●
	WCMT040208-GF	21-25	4.3	6.35	2.38	3.1	0.8		●	●
	WCMT050308-GF	26-30	5.4	7.94	3.18	3.2	0.8		●	●
	WCMT06T308-GF	31-41	6.5	9.525	3.97	3.7	0.8		●	●
	WCMT080412-GF	42-58	8.7	12.7	4.76	4.3	1.2		●	●

Note: ● The Recommended Grade ready to stock

## SP□□ Inserts

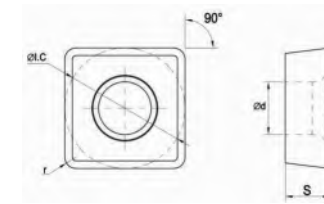

Shape	Type	Boring Range (mm)	Size					Application	Grade	
			L	øl.C	S	Φd	r		PVD	
									VK1025	VK1825
	SPMT050204-GM	12.5-15	5	5	2.38	2.2	0.4	Semi-finishing	●	●
	SPMT060204-GM	15.5-21.5	6	6	2.38	2.6	0.4		●	●
	SPMT07T308-GM	22-27.5	7.94	7.94	3.97	2.8	0.8		●	●
	SPMT090408-GM	28-33	9.8	9.8	4.3	4.2	0.8		●	●
	SPMT110408-GM	34-41	11.5	11.5	4.76	4.4	0.8		●	●
	SPMT140512-GM	42-50	14.3	14.3	5.2	5.75	1.2		●	●

Note: ● The Recommended Grade ready to stock

## SO□□ Inserts

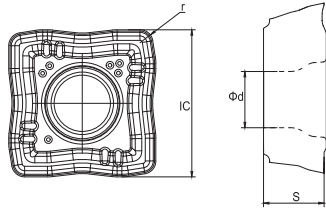

Shape	Type	Boring Range (mm)	Size					Application	Grade	
			L	ØI.C	S	Φd	r		PVD	
									VK1025	VK1825
	SOMT040204-VP	13-16	1	4.4	2.38	2.2	0.4	Semi-finishing	●	●
	SOMT050204-VP	13-16	1.2	4.9	2.38	2.2	0.4		●	●
	SOMT060204-VP	16.5-17	1.8	5.7	2.38	2.6	0.4		●	●
	SOMT070306-VP	17.5-19	1.8	6.8	2.8	2.6	0.6		●	●
	SOMT08T306-VP	22.5-26.5	2	7.8	3.97	2.8	0.6		●	●
	SOMT09T308-VP	27.5-31.5	2.4	9.2	3.97	3.8	0.8		●	●
	SOMT11T308-VP	32-36.5	3	11	3.97	3.8	0.8		●	●
	SOMT130408-VP	37-43	3.2	12.8	4.4	4.5	0.8		●	●

Note: ● The Recommended Grade ready to stock

## SO SP□□ Inserts

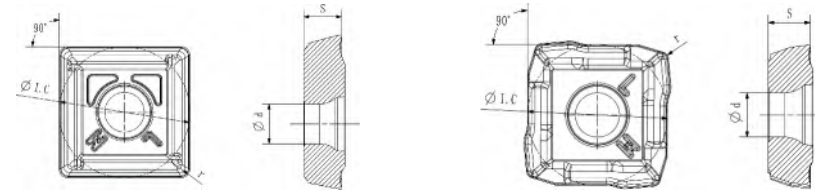

Shape	Type	Boring Range (mm)	Size				Application	Grade	
			ØI.C	S	Φd	r		PVD	
								VK1025	VK1825
	SOMT050305C-LM	24-29	8.40	3.00	3.20	0.50	Medium Machining	●	●
	SOMT060406C-LM	30-41	10.20	3.50	4.00	0.60		●	●
	SOMT070406C-LM	30-41	12.36	4.00	4.00	0.60		●	●
	SOMT080508C-LM	44-63	14.90	4.50	4.70	0.80		●	●
	SOMT090608C-LM	44-63	17.90	5.50	4.70	0.80		●	●
	SPMT050308P-LM	24-29	8.90	3.00	3.20	0.80	Medium Machining	●	●
	SPMT060408P-LM	30-41	10.70	3.50	4.00	0.80		●	●
	SPMT070410P-LM	30-41	12.70	3.95	4.00	1.00		●	●
	SPMT080510P-LM	44-63	15.50	4.50	4.70	1.00		●	●
	SPMT090610P-LM	44-63	18.60	5.50	4.70	1.00		●	●

Note: ● The Recommended Grade ready to stock

## Part One: General Technical Information for Turning Machining

### The Functions of Each Part of Turning Tools

#### 1 The Names of Each Part of Turning Tools

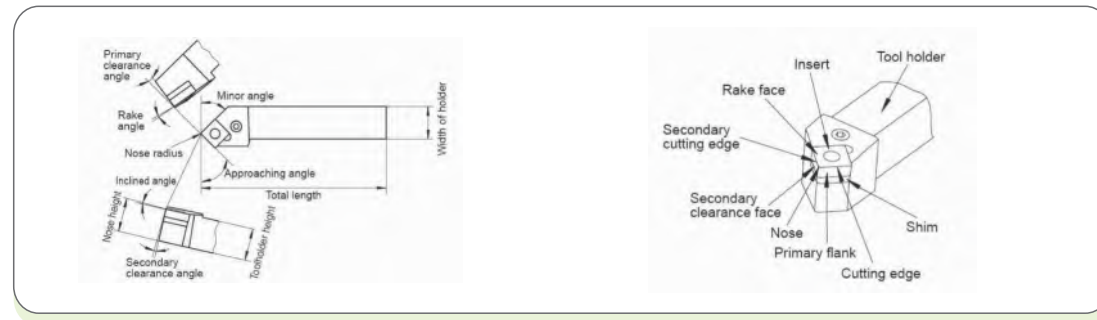

#### 2 Effects of Rake Angle

Larger rake angle makes cutting edge sharper, reduces resistant forces of chip flow, diminishes friction and prevent deformation, leading to smaller, less abrasion and higher surface quality. However, too large rake angle would reduce the rigidity and strength of tool. Heat can't be diffused easily, Serious breakage and abrasion on tool would occur, reducing tool life. Please choose rake angle according to machining conditions.

Value selection	Situations
Small rake angle	<ul style="list-style-type: none"> <li>When machining brittle and hard materials;</li> <li>When roughing and interrupted cutting</li> </ul>
Big rake angle	<ul style="list-style-type: none"> <li>When machining Plastic or soft materials;</li> <li>When finishing;</li> </ul>

#### 3 Effects of Clearance Angle

The main function of clearance angle to reduce the friction between the clearance face of tool and the surface of workpiece. When the rake angle is fixed, larger clearance angle can increase and the achieve higher surface quality. However, if clearance angle is too large, the strength of cutting edge would decrease. Also, heat can't be diffused easily and serious abrasion would occur, reducing tool life. The principle of choosing clearance angle: Choose small clearance angle if friction is not serious

Value selection	Situations
Small clearance angle	<ul style="list-style-type: none"> <li>In order to increase nose strength when roughing</li> <li>When machining brittle and hard materials</li> </ul>
Large clearance angle	<ul style="list-style-type: none"> <li>In order to reduce friction when finishing</li> <li>When machining materials easy to be hardened;</li> </ul>

#### 4 Effects of Inclined Angle

Positive or negative inclined angle determines the direction of chip flow, and also affects the strength and impact resistance of insert nose.

◆ As diagram(1) shows, when the inclined angle is negative, namely nose is in the lowest point as apposed to the bottom of tool, chips flow to the machined surface of workpiece.

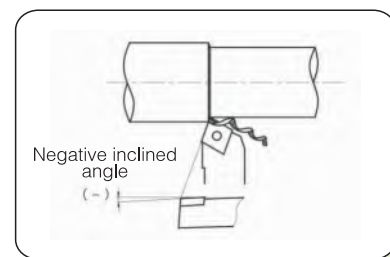

◆ As diagram(2) shows, when inclined angle is positive, namely the nose is in the highest point as apposed to the bottom of the tool, chips flow to the areas of workpiece surface that haven't been machined.

◆ The change of inclined angle also affects insert nose strength and impact resistance. When the inclined angle is negative, the nose is in the lowest point of cutting edge. When the cutting edge enters the workpiece, the contacting point is on the cutting edge or rake face, protecting the nose from impact and increase the strength of the nose. Normally, negative inclined angle should be chosen for tools with big rake angle. This can not only increase nose strength. But also prevent the impact of entry.

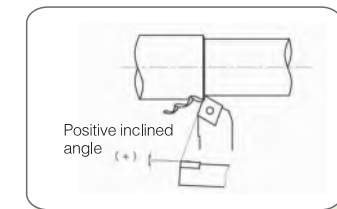

#### 5 Effects of Approach Angle

Reduces approaching angle increases the strength of tools and enable heat to diffuse easily, improving surface quality. This is because when the approach angle is small, cutting edge width is large, and then the unit width of cutting edge bears less cutting force. Meanwhile, tool life can be improved.

Normally, select 90° approach angle for turning of slender and step shaft; select 45° approach angle for external turning, End surface machining and chamfering. When approach angle is larger, radial force is reduced, cutting is stable, cutting thickness is increased, and chip breaking is excellent.

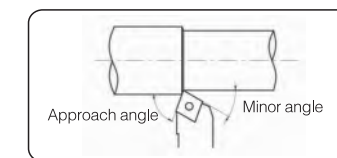

Value selection	Situations
Small approach	For those materials with high intensity, high hardness and hardened layer on the surface
Big approach angle	When rigidity of the machine is not enough

#### 6 Effects of Minor Angle

Minor angle is the main angle that can affect surface quality, and it can also affect tool strength. If the approach angle is too small, the friction between the secondary flank and machined surface of workpiece will increase, causing vibration. The principle of selecting minor angle: Select small minor angle when roughing or when the friction is unaffected and is on vibration. Select large minor angle when finishing.

#### 7 Effects of Cutting Edge Grinding

According to different use occasions, choose a cutting edge method from the table below

Shape of the cutting edge	shape
sharp edge	
comer	
chamfer	

Cutting edge grinding is a processing method used to maintain the cutting edge strength. The grinding amount is large, the cutting edge strength is high, not easy to damage, the tool life is improved, but the excessive grinding amount will cause the edge sharpness is not enough, the cutting force will be large, but also may produce vibration.

Value selection	Situations
Small regrinding amount	<ul style="list-style-type: none"> <li>• Finishing machining – small <math>A_p</math> &amp; <math>F_n</math></li> <li>• For processing soft materials</li> <li>• When the machine or workpiece is not rigid enough</li> </ul>
Large regrinding amount	<ul style="list-style-type: none"> <li>• Rough machining</li> <li>• When machining hard materials and intermittent cutting</li> <li>• When machine rigidity is good</li> </ul>

### ⑧ Nose Radius

Nose radius significantly affects nose strength and surface quality.

Large nose radius means higher cutting edge strength, and the abrasion on the rake face and clearance face can be reduced to some extent. However, if the nose radius is too large, radial force will increase, and vibration is easy to occur, affecting machining precision and surface quality

Value selection	Situations
Small nose radius	<ul style="list-style-type: none"> <li>● Finishing at small cutting depth</li> <li>● Machining parts such as slender shaft</li> <li>● When the rigidity of the machine is not enough</li> </ul>
Large nose radius	<ul style="list-style-type: none"> <li>● When roughing</li> <li>● When machining hard materials (intermittent cutting)</li> <li>● When the rigidity of the machine is good enough</li> </ul>

## Calculation Method of Turning Parameters

### ① Calculation of Cutting Speed

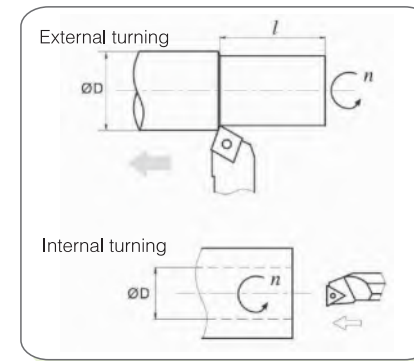

$$V_c = \frac{\pi \times D \times n}{1000} (m/min)$$

In the formula:

$V_c$ : Cutting speed(m/min)

$n$ : Rotating speed of main axle (rev/min)

$D$ : Diameter of workpiece(mm)

For example: When the rotating speed is 500ev/min and the diameter of workpiece is 80mm, the cutting

$$V_c = \frac{\pi \times D \times n}{1000} = \frac{3.14 \times 80 \times 500}{1000} = 125.6(m/min)$$

### ② Calculation of Feed Rate

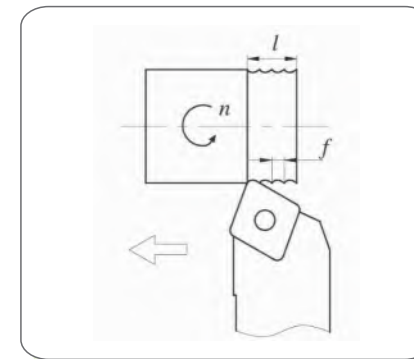

$$f = \frac{l}{n} (mm/rev)$$

In the formula:

$f$ : Feed rate per rotation(mm/rev)

$L$ : Cutting length per minute(mm/min)

$N$ : Rotating speed of main axle(rev/min)

For example: When the rotating speed of main axle is 600ev/min, and the cutting length per minute is 150mm/min, the feed rate per rotating should be:

$$f = \frac{l}{n} = \frac{150}{600} = 0.25(mm/rev)$$

**3 Cutting Time Calculation of External and Internal Turning**

$$T = \frac{l}{f \times n} \text{ (min)}$$

In the formula: T: Cutting time(min)  
 L: length of machined areas(mm)  
 F: Feed rate(mm/rev)  
 N: Rotating speed of main axle(rev/min) For example: When the rotating speed of main axle is 300rev/min, and the feed rate is 0.15mm/rev. the time needed for a cutting length of 180mm should be:

$$T = \frac{l}{f \times n} = \frac{180}{0.15 \times 300} = 4 \text{ min}$$

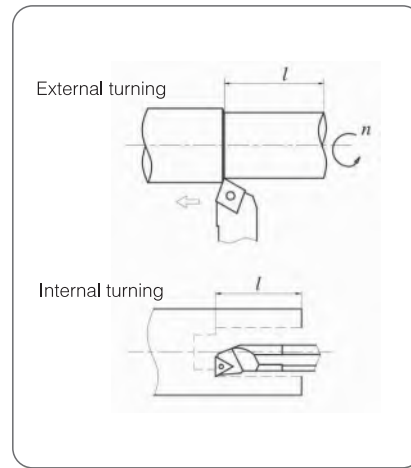

**4 Time Calculation End Surface Turning (Constant Linear Speed)**

$$T = \frac{\pi \times (a^2 - b^2)}{4000 \times V_c \times f} \text{ (min)}$$

In the formula: T: Cutting time(min)  
 Vc: length of machined areas(mm)  
 F: Cutting speed For end surface without hole, b = 0, the formula is still Valid.

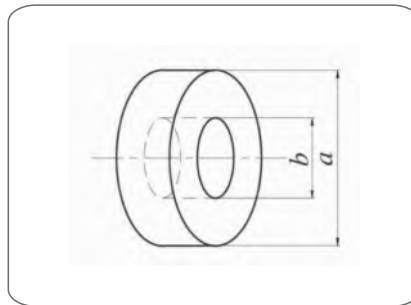

**5 The Oretical Value Calculation of Machined Surface Roughness**

$$R = \frac{f^2}{8r_c} \times 1000 (\mu\text{m})$$

In the formula: R: Theoretical roughness value of machined surface  
 F: Feed rate(mm/rev)  
 Rc: Nose radius(mm)  
 For example: When the feed rate is 0.25mm/rev, and the nose radius is 0.8mm. the theoretical roughness value of machined surface should be:

$$R = \frac{f^2}{8r_c} \times 1000 = \frac{0.25^2}{8 \times 0.8} \times 1000 = 9.76 (\mu\text{m})$$

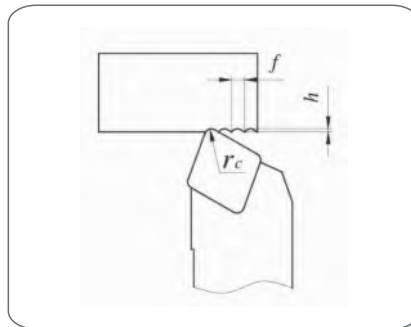

**The Influence of Three Elements of Turning on Machining**

Normally, short machining time, long tool life and high machining precision are expected in machining, so the material quality, hardness, and shape of the workpiece, and properties of machine should be fully considered and then we can select suitable tools and adopt high-efficiency cutting parameters, namely three parameters.

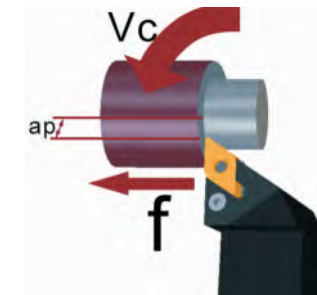

**1 Cutting Speed (Vc)**

(1) Definition of cutting speed

When the workpiece is rotating on the machine, the number of its rotation per minute is defined as Rotating speed of main axle (n). Because of its rotation, the cutting speed measured on the contacting point of diameter is defined as linear speed. (m/min). Normally, linear, linear speed is considered to measure the effect of cutting speed on machining.

(2) Effect of Cutting Speed

Cutting speed has significant effect in tool life. When the cutting speed is increased, cutting temperature will increase and tool life will be shortened. Cutting speed varies according to the different types and hardness of work-piece. The below conclusions are reached after many cutting experiments:

- Normally tool life would be reduced to half when the cutting speed is increased by 20%. Tool life would be 20% of the original life if the cutting speed is raised by 50%.
- Low speed (20-40m/min) cutting could easily cause vibration and shorten tool life.

**2 Feed Rate (Fn)**

(1) Definition of feed rate

Feed rate is defined as the moving distance of tool after workpiece rotates for one circle, measured by mm/rotation.

(2) The influence of feed rate

Feed rate is a key factor that determines surface quality. Meanwhile it also affect the range of chip forming and the thickness of chips during machining.

In term of the effect on tool life, small feed rate leads to serious abrasion on clearance face, reducing tool life.

## ③ Cutting Depth(ap)

### (1) Definition of cutting depth

Cutting depth is defined as the difference between machined surface and unmachined surface. Measured by mm, it is half the difference value between the original diameter and machined diameter.

### (2) Effect of Cutting Depth

Cutting depth should be determined by the machining allowance and shape of workpiece, power and rigidity of machine, and tool rigidity.

The change of cutting depth has little effect on tool life. If the cutting depth is too low, the cutting nose only scrapes the hardened layer on the workpiece surface, reducing tool life. When there is a hardened oxide layer on the workpiece surface, higher cutting depth should be adopted within the possible range of machine's power to avoid cutting nose just cutting the hardened layer of workpiece.

## Blade Wear and Solution

### (1) Flank Wear



**Problem:**  
Higher cutting resistance. Notch wear on flank. Poor roughness of surface or deterioration of accuracy

**Reason:**  
Soft grades. Excessive cutting speed. Small flank angle. Low feed

**Solutions:**  
Select a higher wear-resistant grade. Reduce cutting speed. Increase flank angle. Increase feed



### (2) Crater Wear



**Problem:**  
Uncontrolled chip. Poor surface quality when finishing. High speed processing carbon steel

**Reason:**  
Soft grades. Excessive cutting speed. Excessive feed. The strength of chip breaker. Insufficient

**Solutions:**  
Change to a higher wear-resistant grade. Reduce cutting speed. Reduce feed. Select a higher strength chip breaker

### (3) Plastic Deformation

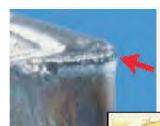

**Problem:**  
Variation of dimension. Nose wear, cutting edge draping or passivating, when processing alloy steel. Poor surface roughness

**Reason:**  
Soft grade. Excessive cutting speed. Excessive cutting depth and feed rate. Overheat on cutting edge

**Solutions:**  
Select a higher red hardness cutting material. Decrease cutting speed. Decrease cutting depth and feed rate. Select a higher thermal conductivity cutting material (CVD + sufficient coolant)

### (4) Build-Up-Edge



**Problem:**  
Workpiece dissolves with cutting edge. Poor surface roughness when finishing. Cutting resistance increased. Cutting soft materials

**Reason:**  
Cutting speed too low. Cutting edge obtuse. Unsuitable tool material

**Solutions:**  
Increase cutting speed. Increase rake angle. Select small sticking force

### (5) Chip Hammering



**Problem:**  
Part of the cutting edge that does not participate in cutting is damaged by chip hammering, the upper and support of the insert may be damaged.

**Reason:**  
Chip folds back to the cutting edge

**Solutions:** Change the feed rate and choose another type of chip breaker

### (6) Insert Fracture



**Problem:**  
Cutting resistance increased. Poor surface roughness

**Reason:**  
Toughness insufficient. Excessive feed rate. Strength of cutting edge insufficient. Instability of the tool

**Solutions:**  
Select a tougher grade. Decrease feed rate. Increase honing of cutting edge (chamfering to rounding). Increase the stability and setting angle

### (7) Thermal Crack



**Problem:**  
Crack by heat cycle (often happens in milling and interrupted cutting)

**Reason:**  
Toughness of tool grade insufficient. Swell and shrink by cutting heat (cold-thermocycling)

**Solutions:**  
Cutting without coolant/sufficient coolant. Select a tougher and more thermal shock resistance grade

### (8) Chipping



**Problem:**  
Sudden fracture of cutting edge (rake face and flank). Instability insert life

**Reason:**  
Toughness insufficient. Excessive feed rate. Strength of cutting edge insufficient. Instability of the tool

**Solutions:**  
Select a tougher grade. Decrease feed rate. Increase honing of cutting edge (chamfering to rounding). Increase the stability and setting angle

## Second Part: Technical Information About Indexable Milling Tools

### Function of Each Part in Face Milling

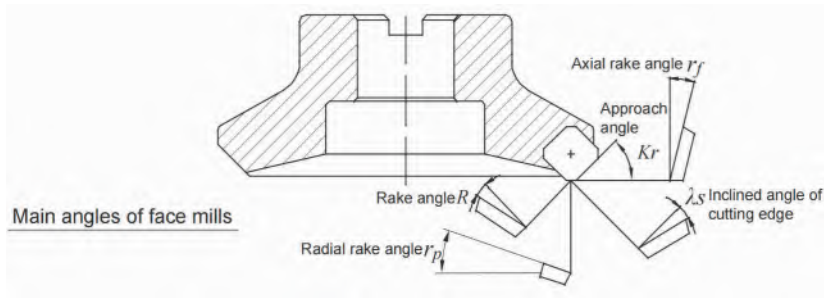

Designation	Function	Effect
Axial rake angle $\gamma_f$	Determining the chip direction	Negative, excellent capability of chip removal
Radial rake angle $\gamma_p$	Determining whether the cutting is easy and fast or not	Positive angle: good cutting performance
Approach angle $K_r$	Determining the chip thickness	$K_r \uparrow$ , chip thickness $\uparrow$ ; $K_r \downarrow$ chip thickness $\downarrow$
Rake angle $R_o$	Determining whether easy and fast the cutting is or not	Poor cutting performance, High - Poor cutting strength cutting edge (-) $\leftarrow \rightarrow$ (+) Good cutting performance, Low strength cutting edge
Inclined angle $\lambda_s$	Determining the chip flow direction	Poor capability of chip removal, High - strength cutting edge (-) $\leftarrow \rightarrow$ (+) Good performance of chip removal, Low - strength cutting edge

### 1 Milling Cutter Parameters Selection

• Characteristics of Different Rake Angles Combined

		Double positive rake angle	Double negative rake angle	Positive and negative rake angle
Negative rake angle				
0° rake angle				
Positive rake angle				
Axial rake angle $\gamma_f$		+	-	+
Radial rake angle $\gamma_p$		+	-	-

Applicable material machined	P	✓		✓
	M	✓		✓
	K		✓	✓
	N	✓		
	S	✓		✓

### 2 Selection of Approach Angle

• Selection Method of Cutting Tools

Designation	Schematic diagram	Instruction
45°		Axial force is the largest, it will bend when machining thin-wall workpiece, reducing the precision of workpiece. It can help avoid fringe breakage of workpiece when machining cast iron
75°		The main force is radial cutting force, in is often used in general face milling
90°		The main force is radial cutting force, in is often used in general face milling

### 3 Selection of Approach Angle :

The approach angle is formed by insert and tool body. It affects chip thickness. Cutting forces and tool-life. Decreasing the approach angle reduces chip thickness and expands the cutting area between cutting edge and workpiece at a given feed rate. A Smaller approach angle also ensures stable entry into or exiting workpiece, protecting the cutting edge and extending tool life. However, this will increase axial cutting forces on the workpiece, thus is not suitable for machining thin workpiece Such as thin plate.

Approach angle	Feed rate per tooth $f_z$	Maximum chip stickiness $h_{ex}$
90°	$f_z$	$h_{ex} = f_z \times \sin Kr$
75°	$f_z$	$h_{ex} = 0.96 \times f_z$
60°	$f_z$	$h_{ex} = 0.86 \times f_z$
45°	$f_z$	$h_{ex} = 0.707 \times f_z$
Circular Blade	$f_z$	$h_{ex} = \frac{\sqrt{ic^2 \times (ic - 2a_p)^2}}{ic} \times f_z$

### 4 Pitch Selection

Pitch is the distance between one point on one cutting edge and the same point on the next edge.

Optimized stability		
L ( Low )	M ( Medium )	H ( High )
<p>Coarse pitch</p>	<p>Close pitch</p>	<p>Extra close pitch</p>
<p>When the milling width is equal to diameter of cutter, the machining system is stable and main power of machine is sufficient, the use of coarse pitch can achieve high productive efficiency.</p>	<p>Used in general milling and multiple mixed productions.</p>	<p>When the milling width is less than diameter of cutter, cutting by maximum edges can achieve high productive efficiency.</p>

## Milling Calculation

### 1 General Formula

$V_c$ : cutting speed ( m/min ) $D_c$ : nominal diameter of milling tool ( mm ) $n$ : spindle speed ( rev/min ) $z_n$ : number of teeth $Q$ : metal removal rate (cm <sup>3</sup> /min)	$V_f$ : feed rate of worktable ( feed speed ) ( mm/min ) $f_z$ : feed rate per tooth ( mm/z ) $\pi$ : circumference ratio=3.14 $T_c$ : machining time ( min ) $f_n$ : feed rate per revolution ( mm/rev ) $L$ : Actual working distance ( mm )	
<p>●Cutting speed</p> $V_c = \frac{\pi \times D_c \times n}{1000} \text{ ( m/min )}$		
<p>●Spindle speed</p> $n = \frac{1000 \times V_c}{\pi \times D_c} \text{ ( rev/min )}$		
<p>●Feed rate of worktable(feed speed)</p> $V_f = f_z \times n \times z_n \text{ ( mm/min )}$		
<p>●Feed rate per tooth</p> $f_z = \frac{V_f}{n \times z_n} \text{ ( mm/z )}$		
<p>●Feed rate per revolution</p> $f_n = \frac{V_f}{n} \text{ ( mm/rev )}$		
<p>●Machining time</p> $T_c = \frac{L}{v_f} \text{ ( min )}$		
<p>●Metal removal rate</p> $Q = \frac{a_p \times a_e \times V_f}{1000} \text{ cm}^3 / \text{min}$		

## Difference and Selection Between Down Milling and Up Milling

Climb milling (also called down milling): the feed direction of workpiece is the same as that of the milling rotation at the connecting position.

Conventional milling (also called up milling): the feed direction of workpiece is opposite to that of the milling rotation at the connecting position.

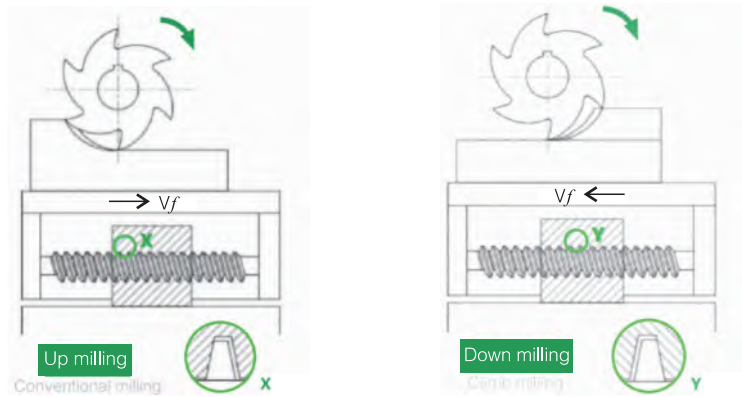

In down milling, the major force of cutting edge is the compressive stress, while in up milling is the tensile stress. The compressive strength of cemented carbide material is much larger than its tensile strength. In down milling, as chips become thin from thick gradually, cutting edge and workpiece press against each other. The friction between edge and workpiece is small, thus reducing the abrasion of edge, the hardening of workpiece surface and the surface roughness (Ra). In up milling, chips become thick from thin gradually. When the insert is cutting into the workpiece, it produces strong friction and more heat than in down milling, and make workpiece surface hardened.

In up milling, because horizontal direction of cutting force milling cutter conducting on workpiece is opposite to the feed direction of workpiece, the lead screw of worktable joints closely with one side of the screw nut. In down milling, the direction of cutting force is the same as the feed direction. When edge's radial force on workpiece is large enough, the worktable will bounce left and right, thus make the gap fall behind. The gap will return to the front side with the continuing rotation of lead screw. At this moment the worktable stops motion, however, it will bounce left and right again when the radial cutting force is large enough again. The periodical bounce of worktable will cause poor surface quality of workpiece and tool breakage.

When using end mills for down milling, the edges always starts cutting at the workpiece surface, therefore end mills are not suitable for machining workpiece with hardened surface

Up milling is recommended for milling thin-wall components or square milling with high requirement for precision.

## CVD Grades Comparison Table

ISO	WeCoTool	SANDVIK	KENNAMETAL	SecoTool	ISCAR	TaeguTec	Walter	TUNGALOY	KYOCERA	KORLOY	SUMITOMO	MITSUBISHI	ZCC.CT
<b>P10</b>	VK4415	GC4315	KCP10 KC9110	TP1500	IC5005 IC8150	TT8115	WPP05S WPP10S	T9115	CA5505 CA5515	NC3215	AC810P AC820P	UE6110 MY5015	YBC151 YBC152
<b>P20</b>	VK4425	GC4325	KCP25 KC9125 KC9225	TP2500	IC8150 IC8250	TT5100 TT8125	WKP25S WPP20S WMP20S	T9025 T9125	CA5515 CA5525	NC3225 NC3120 NC5330	AC2000 AC820P	UE6020 MC6025 F7030	YBC251 YBC252
<b>P30</b>	VK4435	GC4325 GC4335	KCP30 KCP40	TP3000	IC8250 IC8350	TT8125 TT5100	WKP35S WPP30S WMP20S	T9135 T9035	CA5525 CA5535	NC3030 NC5340 NC500H	AC630M AC830P	UE6020U E6035U H6400	YBC252 YBC351
<b>M10</b>		GC2015	KCM15		IC6015 IC8150	TT9215	WMP20S		CA6515 CA6015	NC9115	AC610M AC630M	US7020 MC7015	YBM251 YBM153
<b>M20</b>		GC2015 GC2025	KCM15 KC9225	TM2000	IC6025 IC8150 IC8250	TT9225	WMP20S	T6020 T6130	CA6515 CA6525	NC9115 NC9125 NC5330	AC630M AC830P	US7020 MC7015 MC7025	YBM251 YBM253
<b>M30</b>		GC2035 GC2025	KCM25 KC9230	TM4000	IC6025 IC8250 IC8350	TT5100	WSM45X	T6130	CA6525	NC5340 NC5350 NC9135	AC630M	MC7025 US735 F7030	YBM351
<b>K10</b>		GC3210 GC3215	KCK05 KCK15	TK1000	IC5005 IC5010	TT1300	WAK15 WPP01	T5010 T5115	CA4505 CA4010	NC6315	AC410K	UC5115 MY5015	YBD102 YBD152
<b>K20</b>	VK3115	GC3215	KCK15 KCK20	TK2000	IC5005 IC5010	TT7105 TT7310	WKP25S WPP10S	T5115 T5125	CA4515 CA4115	NC6315 NC5330	AC410K AC420K	UC5115 UE6110 MC5020	YBD152
<b>K30</b>	VK3040	GC3225	KC9325		IC5010		WKP35S WPP20S	T5125		NC5340	AC820P	UE6110	YBD252

# PVD Grades Comparison Table

ISO	WeCoTool	SANDVIK	KENNAMETAL	SecoTool	ISCAR	TaeguTec	Walter	TUNGALOY	KYOCERA	KORLOY	SUMITOMO	MITSUBISHI	ZCC.CT
<b>P10</b>	VK1025	GC1010 GC1025	KC715M		IC807 IC907	TT7030 TT7080	WXM15 WSM10 WSM10S		PR730 PR830 PR1225		ACP100 ACP200	VP10MF	YBG102 YBG105
<b>P20</b>	VK1825 VK1525 VK1025	GC1010 GC1025 GC2030	KC522M KC525M	CP200	IC807 IC907 IC3028	TT7030 TT9030 TT9080	WSM20 WSM20S WSM21	AH725 AH120 GH330	PR730 PR830 PR1225	PC3600	ACP200	VP15TF VP20RT VP20MF	YBG202 YBG205
<b>P30</b>	VK1025	GC1025 GC1030	KC725M KC530M	CP500	IC807 IC808 IC3028	TT8080 TT9030 TT9080	WSP45S WSP46 WSM30S	AH730 GH130 AH130	PR660 PR1230	PC3600 PC3500 PC5300	ACZ300 ACZ350 ACZ200	VP15TF VP30RT VP20MF	YBG302
<b>M10</b>	VK1824	GC1025 GC1030	KC715M	CP200	IC807		WSM10 WSM10S		PR630 PR730 PR1225	PC8105 PC8110	ACP200	VP10MF	YBG202 YBG205
<b>M20</b>	VK1824 VK1525 VK1828	GC1025 GC1030	KC5025 KC715M	CP200 TS2500 CP500	IC354 IC807 IC3028	TT9030 TT9080	WSM20 WSM20S WSM21	GH120 AH120 AH725	PR660 PR730 PR1225	PC8110 PC8115 PC5300	ACZ310 AC520U ACP300	VP15TF VP20RT VP20MF	YBG202 YBG205 YB9320
<b>M30</b>	VK1828	GC1030 GC1040 GC2030	KC725M KC5525	CP500 F30M	IC808 IC908	TT8080 TT9030 TT9080	WSP35S WSP36 WSM30S	AH130 GH130 AH730	PR660 PR730	PC5300 PC9530 PC5400	ACZ330 AC520U ACZ350	VP15TF VP30RT MP7030	YBG302 YBG402
<b>K10</b>	VK1015	GC1210	KC5010 KC510M	CP200	IC910		WHH15 WXM15	AH110 GH110	PR510 PR905 PR1210	PC8110 PC6510	ACZ310 ACK200	VP10RT	YBG102 YBG105
<b>K20</b>	VK1825 VK1525 VK1025	GC1020 GC1220	KC5025 KC520M KC525M	CP200 CP500	IC808 IC908	TT6080	WKK25S	AH120 GH110 AH330	PR905 PR1210	PC5300	ACZ310 ACK200	VP15TF VP20RT	YBG202
<b>K30</b>	VK1025	GC1020	KC735M KU25T	CP500	IC808 IC908		WKK25S	GH130		PC5400	ACZ330 ACK300	VP15TF VP20RT	YBG205 YBG302
<b>S10</b>	VK1605 VR1610	GC1025	KC510M KC5510 KCS10B	CP200 TS2000	IC806	TT9030	WSM10 WSM10S	AH905 AH110 SH730	PR660 PR905	PC8105 PC8110	EH520Z EH20Z AC510U	VP10RT VP20RT	YBS103
<b>S20</b>	VK1525 VR1520 VR1525	GC1025 GC2030	KC522M KC525M KC5525	CP250 TS2500 CP500	IC806 IC807 IC808	TT9030 TT9080	WSM20 WSM20S WSM21	AH120 AH725	PR1225 PR905	PC8115 PC5300	EH520Z EH20Z AC520U	VP15TF VP20RT MP9130	YBS203
<b>S30</b>	VR1029 VR1030	GC2030 S30T	KC725M	F40M	IC8350	TT8080 TT9030 TT9080	WSM45S WSP46 WSM30S	AH725	PR905	PC5400	ACK300 AC520U	VP15TF	YBS303